



**Precision  
Stairways**

**AUTOMATIC ELECTRIC  
DISAPPEARING STAIRWAY  
O&M MANUAL**

**PROJECT:** \_\_\_\_\_  
\_\_\_\_\_  
\_\_\_\_\_

**STAIRWAY MODEL:** \_\_\_\_\_  
**PRECISION SERIAL #** \_\_\_\_\_

**SOLD TO:** \_\_\_\_\_

**UPON RECEIVING UNIT, CAREFULLY UNCRATE AND CHECK UNIT AND PARTS FOR DAMAGE CAUSED DURING SHIPPING.**



## **THE PRECISION AUTOMATIC ELECTRIC DISAPPEARING STAIRWAY PARTS LIST**

1. (3) Furnas Limit Switches, 2-up (D) on inside of frame and 1-down (D) on motor mount.
2. Operating Switches: Toggle-switch on motor upstairs; Toggle at end of 20' of 3-Conductor Cable for mounting on wall downstairs (Optional: Key-switch downstairs)
3. Electric Motor: 1/3HP, 115-V, instantly reversible, normally mounted on right side; if specified, on left side
4. Worm Gear Reduction; 60 to 1
5. Electrical Box (Magnetic Contactors, Relays)
6. Drive Chain
7. Chain Drive Sprocket (small – 20 tooth)
8. Driven Sprocket (large - 40 tooth)
9. Steel Cables
10. Cable Clamps (upper end of cable)
11. Tension Springs (upper end of cable)
12. Cable Eye-bolts (for take up)
13. Cable Guide-rollers (brass)
14. Handrail Guide-rollers (2 each side)
15. Spur Gears (4)
16. Track Ball-bearing
17. Drive-shafts (2)
18. Drive-shaft Bearings (9)
19. Handrail & Track Assembly (right)
20. Handrail & Track Assembly (left)
21. Stop for Down Limit Switch, mounted on top end of Stairway
22. Steel Rollers (2)
23. Door Panel: Aluminum
24. Insulation
25. Optional: Hand Wheel on Shaft for Emergency lowering of unit

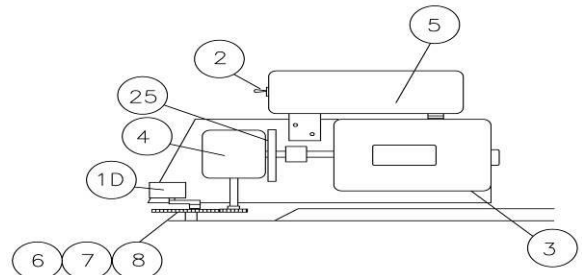

**MOTOR ASSEMBLY**

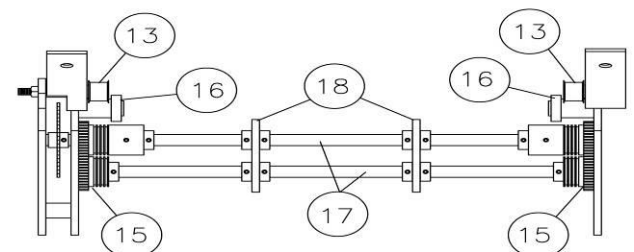
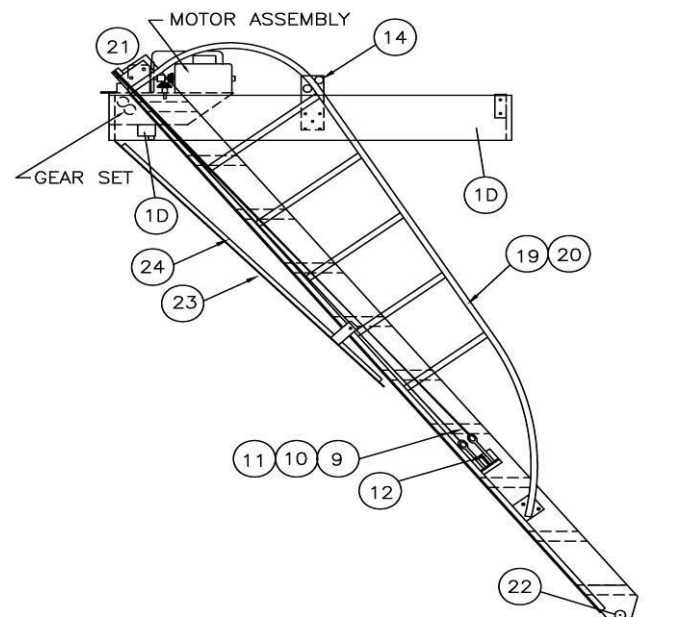

**GEAR SET**  
(FROM BACK OF FRAME)

# Wiring

All wiring and electrical connections must comply with the National Electrical Code (NEC) and local electrical codes. In particular, refer to Article 430, "Motors, Motor Circuits and Controllers", of the NEC.

Use of a motor starter, either manual or magnetic, incorporating thermal protection, is advisable and may be required by local electrical codes. Follow motor starter manufacturer's recommendations on thermal overload relay heater selection. Do not oversize heaters. On 3-phase systems, three (3) heaters must be used.

Wherever possible, each motor should be powered from a separate branch circuit of adequate capacity to keep voltage drop, during starting and running, to a minimum.

Increase wire size where the motor is located a distance from the power source.

Where extension cords are used, they should be as short as possible, for minimum voltage drop. Long or inadequately sized cords, especially on hard starting loads, can cause motor failure. Always use grounding-type (3-conductor) extension cords in conjunction with a properly connected, grounding-type receptacle.

## Minimum Wire Sizes for Wiring and Extension Cords

**Motor 25 Feet 50 Feet 100 Feet 150 Feet 200 Feet**  
**HP 115V 230V 115V 230V 115V 230V 115V 230V 115V 230V**

1/6 18\* 18\* 14 18\* 12 16\* 10 16\* 8 14

1/4 16\* 18\* 14 18\* 10 16\* 8 14 8 12

1/3 14 18\* 12 18\* 10 16\* 8 14 6 12

1/2 14 16\* 12 16\* 8 14 6 12 6 12

3/4 12 16\* 10 16\* 8 14 6 12 4 10

1 12 16\* 10 14 6 12 4 10 4 10

1 1/2 10 14 8 14 6 12 4 10 2 8

2 10 14 6 12 4 10 2 8 2 6

NOTE \* Use only #14 AWG or larger wire for permanent installations

To connect motor for proper voltage and rotation, refer to the connection diagram located on the nameplate or inside the terminal box. On three phase motors, interchange any two line leads to reverse rotation. On centrifugal pump applications involving a 3-phase motor with threaded shaft, motor rotation must be counterclockwise as viewed facing shaft end.

On air compressors with fan-type flywheels, rotation should be such as to blow air towards the cylinders. Look for rotation arrow on side of flywheel.

# AUTOMATIC ELECTRIC DISAPPEARING STAIRWAY WIRING DIAGRAM

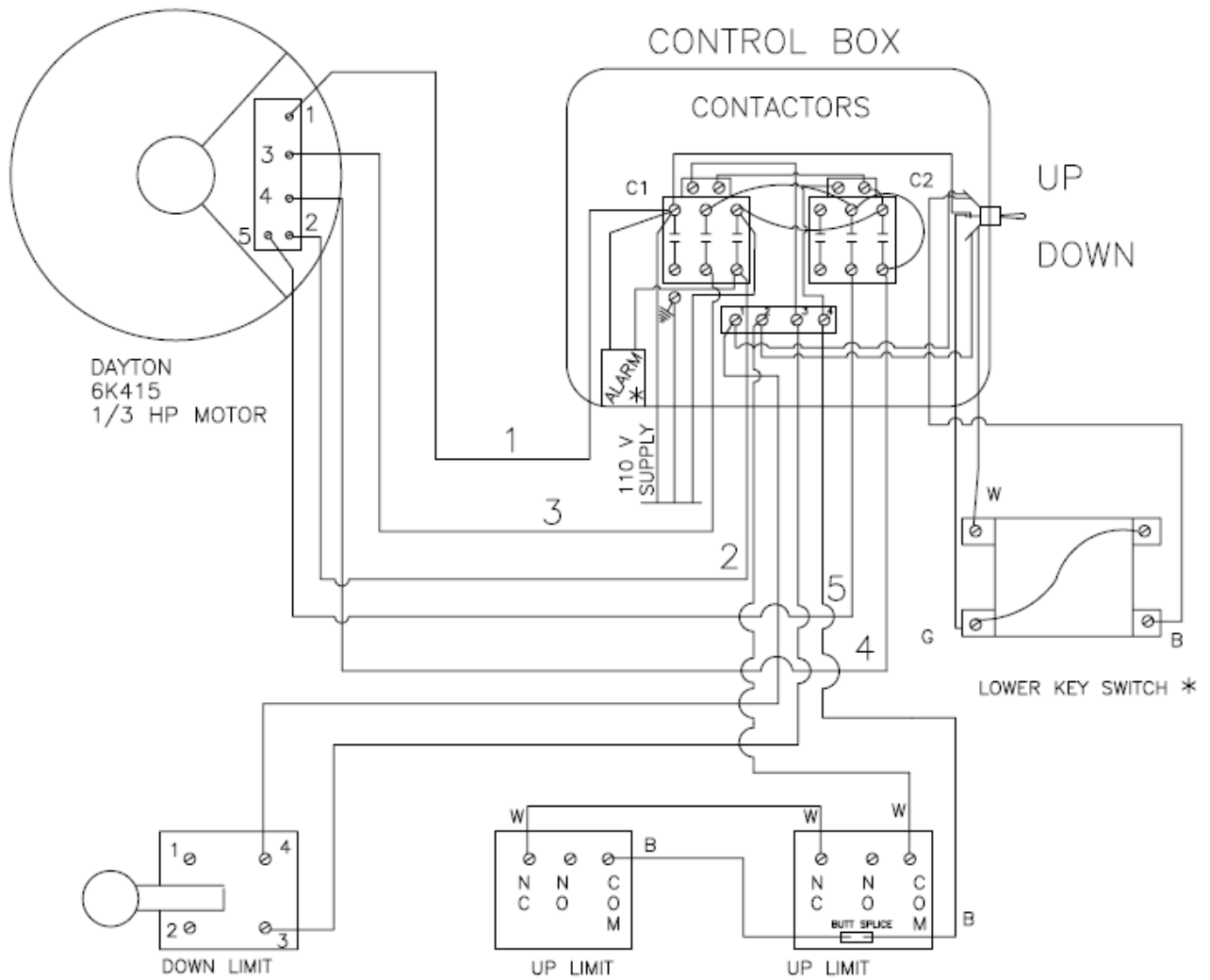

\* OPTIONAL

# Precision Automatic Electric Disappearing Stair Standard Installation Instructions Using - BOX FRAME

Open the stairway to about "FULL-OPEN" after uncrating, by turning the shaft at the coupling (by hand). If possible, install the unit by lowering it into position from the upper floor level. If not possible, attach a hoist to the lifting bracket (sent with unit), and lift through the opening. In this case it is necessary, remove four (4) side frame brackets (and the motor support mount and motor), disconnecting the electric cable at the disconnect plug. After the top of the stair frame is raised through the opening to the upper floor level, replace the frame brackets and motor mount, etc. Check adjustment of the motor to be sure there is no slack in the chain. If motor mount needs removal, remove chain guard by taking off (2) 1/4" nuts and take out the 7/16" pivot nut and the 2 3/8" bolts.

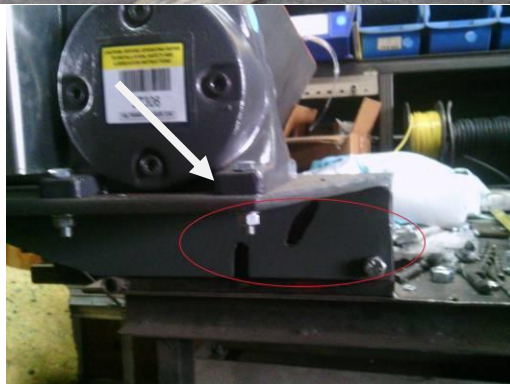
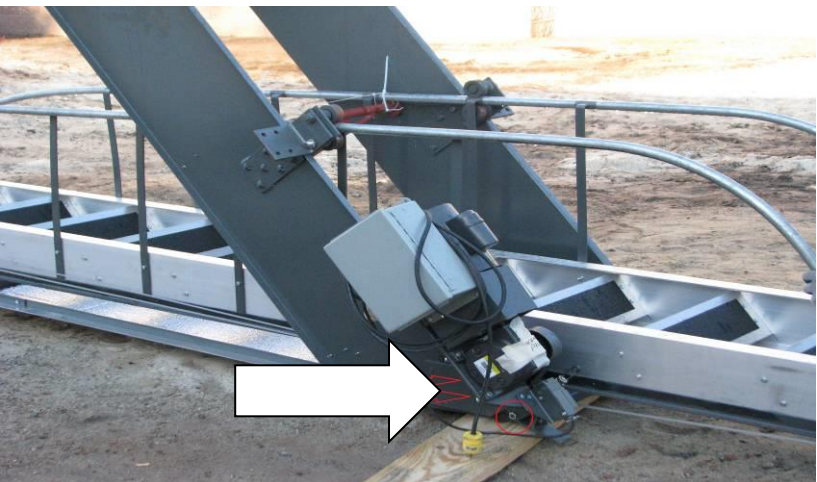
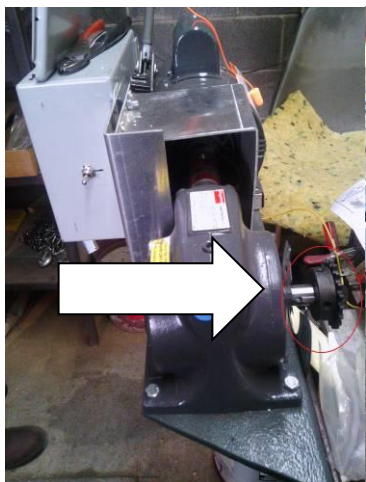
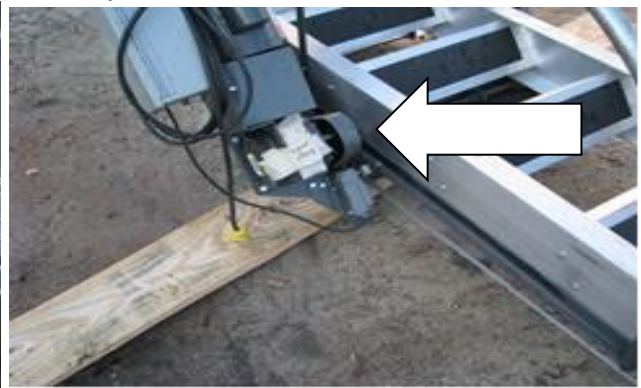
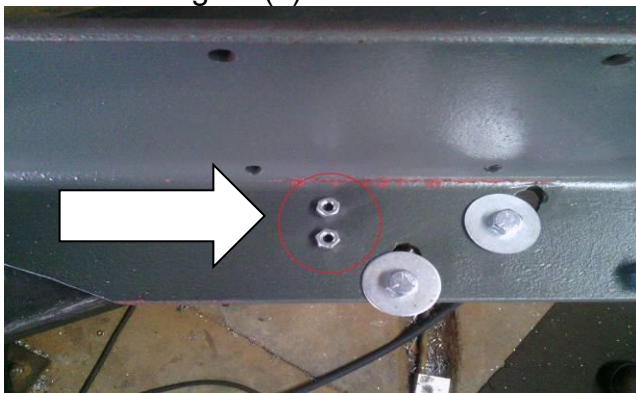

Let mount down and remove chain. Lay motor mount assembly over in stairway. After the frame is mounted, reverse the procedure.

Secure the framed unit into the rough opening. The proper level is obtained if all six (6) anchor-brackets are level with each other, and flush (horizontal) with the UPPER FLOOR LINE (if the floor is level). Wedge (shim) between the steel frame and the rough opening, and further secure the unit through shims, making sure the four (4) inside corners of the frame are at 90 degrees, and the sides of the frame are straight; this is important for proper operation. Be sure that adequate wedging is done beneath the "UPRIGHTS" which hold the handrails.



**--- DO NOT POUR CONCRETE AROUND THE FRAME --**

Next, bolt-down the frame to the upper floor with 3/8" fasteners (for type of structure concrete, metal, etc...), through the six (6) anchor-brackets. When properly secured (frame-to-rough-opening), the unit is ready for connecting to the electrical supply.

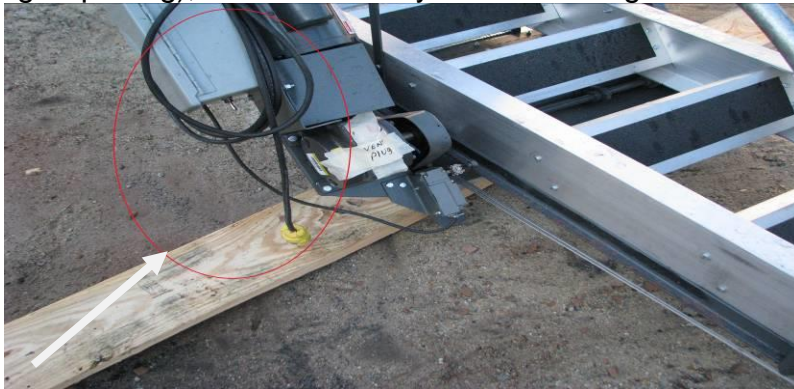

\*\* There is a toggle switch upstairs at the motor, and another toggle switch (optional extra: key-switch) at the end of about 20' of 3-wire cable\* which should reach to a lower-floor wall receptacle of your choice. A wiring diagram is sent along with each electric stairway.

NOTE: Your fusing for the motor circuit should be downstairs, where it can be reached easily, in case of replacement need. After your job-wiring-connections are completed, the stairway is then ready for operation. Two (2) limit-switches control the "FULL-UP" as well as the "FULL-DOWN" positions and "CUT-OFF". The wall-switch, spring loaded so that it must be held in an "ON" position to operate, controls the up and down travel of the stairway; the same for the upstairs switch.\* Grounded connection in junction box upstairs. \* Bring 110-V to the junction box upstairs.

When the above is checked out, run the stairway to the "UP" (closed) position. Then, check the frame's sides to see that they are straight and parallel. If so, then the unit is ready for use. ("EXTRAS" may include a warning buzzer when the unit is operating, a key-switch for the wall downstairs, and battery backup, in the event of power failure, etc.) If ceiling "slab" is less than frame, block under the anchor-brackets.

## RESTRINGING CABLES

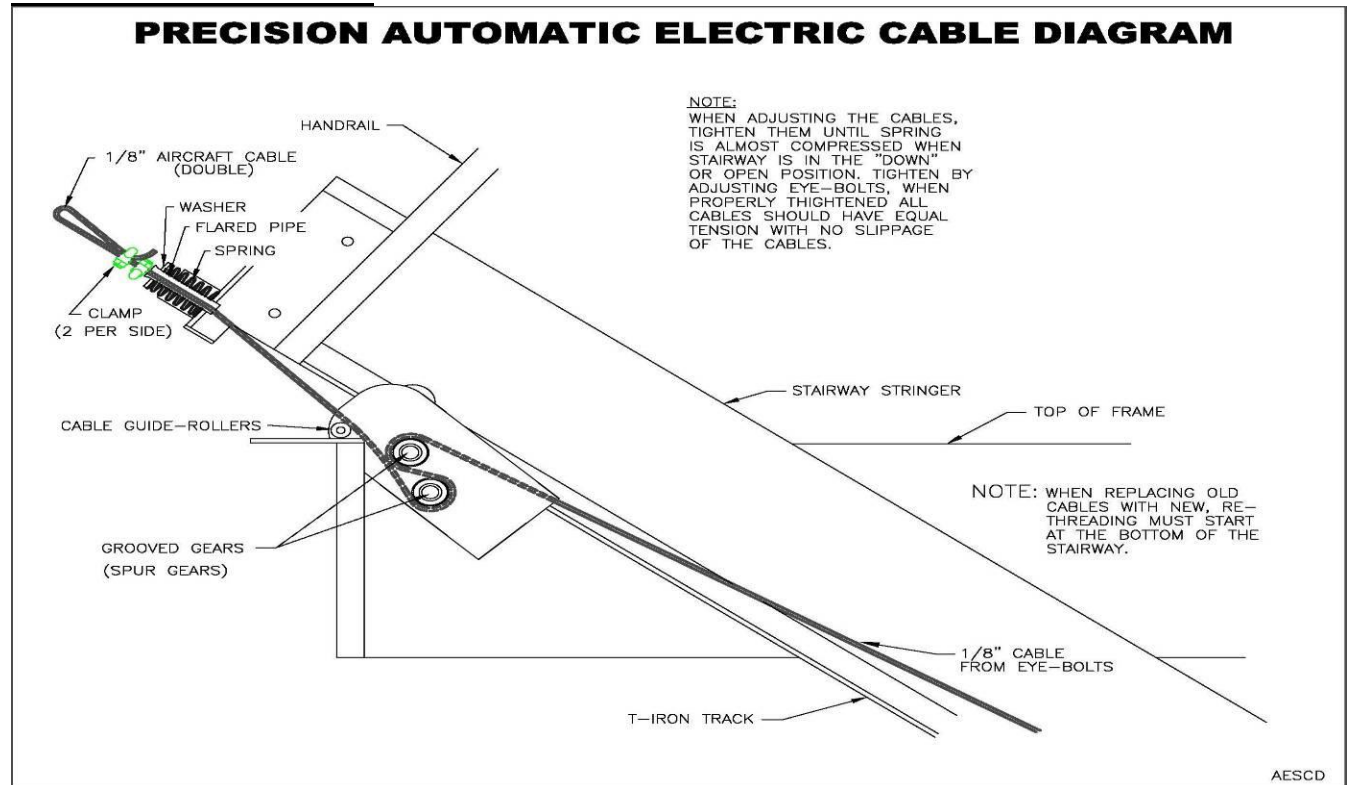

If restringing is needed follow the steps below:

1. Always start with outside cable
2. Keep cables together
3. Start with bottom eyebolt and outside cable

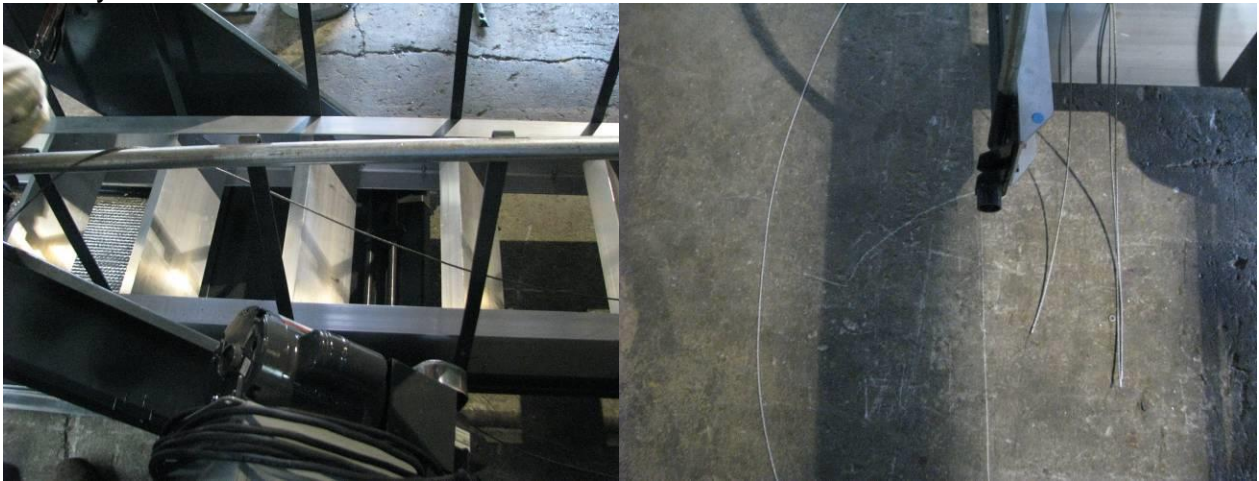

4. Keep ends of cables the same length to crimp at eyebolt
5. Make sure stairway is in middle of frame (count steps on each side)



6. Cable must go in first groove of cable guide 7. Do one side at a time (keep tension on each cable(s))



8. Each cable needs its own groove (if cables are spaced on grooves you must restart)  
9. Keep tension, then clamp at brass guide 10. Run each cable through spring compressor (start with outside cables, then inside 2 cables)



11. Use a clamp to keep spring tensioner in cable support system 12. Pull two outside cables separately and then two inside cables separately; clamp with cable clamp (use two clamps) 13. Loop cables into last clamp and tighten



14. Take off clamp from spring tensioner and cable support system. 15. Complete steps 1 through 14 on other side of stairway.



16. Loosen copper crimps on cables 17. Adjust eyebolts (start with ¼ inch tightening; you should about be able to squeeze cables together)

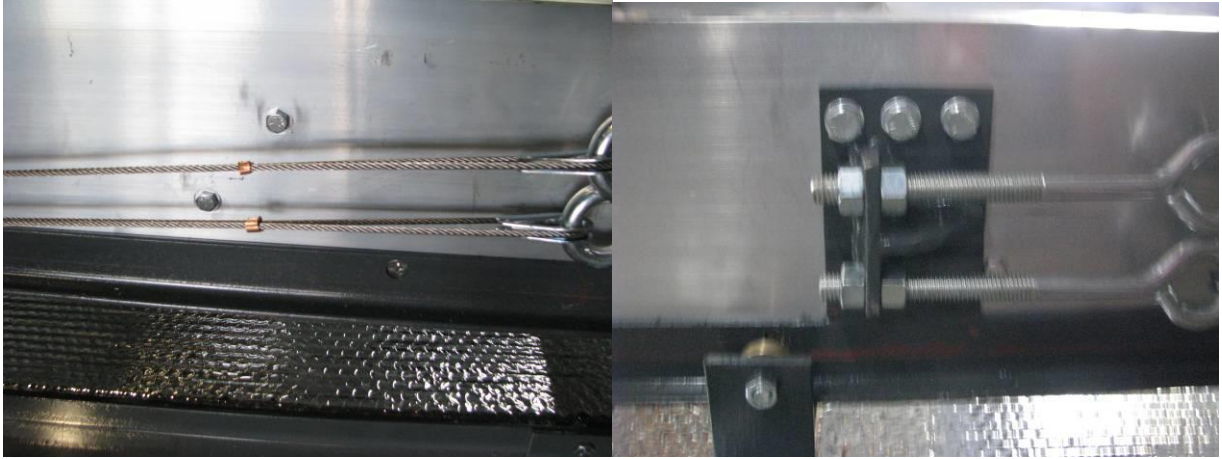

18. Recrimp copper crimps 19. Set Limits



# Maintenance Recommendations - Box Frame

## GEARS

Hard grease - occasional use - every six (6) months.



## CABLE TENSION

Tension should remain equal on both sides; do not allow slippage. Maintain equal tension by adjusting eyebolts, if necessary. If cable is frayed from use, order new.

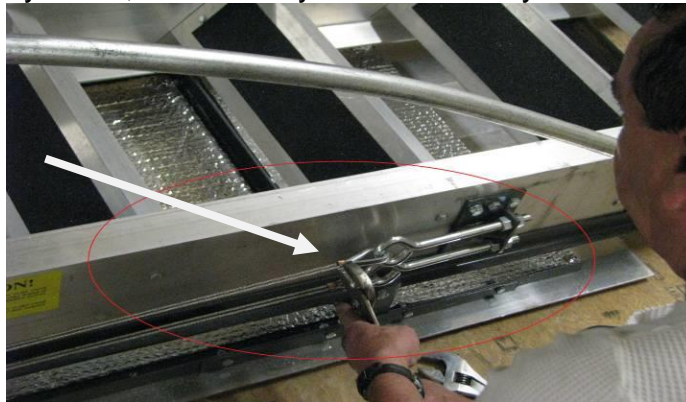

## REDUCTION GEAR

Use 90-weight oil. Check the level every six (6) months.



## LIMIT STOPS

Upper and lower limit switches inside frame, one (1) at each end. The door panel and upper part of stair trip the switches.



## SERIAL NUMBER

Stair Serial Number is on the bottom step of stairway. ALWAYS GIVE SERIAL# to Manufacturer when ordering parts.



# **Precision Automatic Electric Disappearing Stair Standard Installation Instruction Using - DEEP FRAME MODELS**

- In 52 degree angle frame, for ceilings 13" to 48" thick, maximum
- 1. A lifting bracket has been included for lifting the entire unit, as it is, into the rough opening.
- 2. 4 frame brackets and the motor mount assembly are to be removed temporarily so the unit can pass through the rough opening. Clamps on the handrails are NOT TO BE REMOVED UNTIL the unit is installed in the rough opening and the motor unit is engaged with the chain-drive. When using lifting bracket, place lifting bracket from 2<sup>nd</sup> up rigor (uprights on handrail). With correct placement of lifting bracket, the unit will be close to level.

3. When the top of the stair frame has been raised sufficiently through the rough opening, replace and secure items removed in paragraph #2.
4. After making certain that the frame is level and square in the rough opening, bolt down the frame to upper floor through the frame-anchor-brackets at the four (4) corners only, using 3/8" fasteners (dependent upon concrete, metal, etc...).
5. When unit is secure in the rough opening, it is ready for connecting (\*) the electrical supply. Then run the stairway to its "CLOSED" position and check the sides of the frame to make sure they are straight and parallel. Then, bolt to the floor through the remaining two (2) brackets at the uprights. (\*) Bring 115-Volts to the junction box upstairs.

**--- DO NOT POUR CONCRETE AROUND THE FRAME ---**

- A. The up and down toggle switch is attached to a 3-wire cable for your convenience. This should be long enough to reach the wall location at the lower floor level. It is wired in the proper manner, coded for your guidance when removing it for the wall installation. The upper level operating switch is conveniently located on the control box next to the motor. The optional key-switch is at the end of the cable for downstairs.
- B. The fuse for the motor circuit should be downstairs, where it is easily replaced. A grounded connection is in the junction box.
- C. Limit switches in the frame control both the "FULL-UP" and "FULL-DOWN" positions, tripped by door and carriage.
- D. The wall-switch controls the UP and DOWN travel of the stairway.

