

**IFB NO. 1109382**



**STRATHMORE MANSION  
ELEVATOR RENOVATION MONTGOMERY  
COUNTY MARYLAND**

**DEPARTMENT OF GENERAL SERVICES  
Division of Facilities Management  
1301 Seven Locks Road  
Rockville, MD 20854**

**Issued: July 28, 2020**

**Pre-Submission Conference/Meeting on:**

Thursday August 6, 2020 at 1:00 P.M at  
Strathmore Mansion, 10701 Rockville Pike  
Rockville, Maryland 20852

**Virtual Bid Opening Via Dial In:**

August 31, 2020 at 12:00 P.M.

Dial In #: **1 443-692-5768**

Conference ID: 339 711 825#

This page left blank intentionally

**MONTGOMERY COUNTY, MARYLAND**  
**INVITATION FOR BIDS**  
**GENERAL INFORMATION**

**NOTE TO POTENTIAL BIDDERS:**

Your bid is to be returned in a sealed envelope that should be at least 9-1/2" x 12-1/2" in size, and is to be clearly marked with the IFB number, the Opening Date, and the Opening Time. The County will not be responsible for premature or late opening of a bid that is improperly addressed or identified. Bids must be received at the **Office of Procurement, Rockville Center, 255 Rockville Pike, Suite 180, Rockville, MD 20850-4166 prior to the date and time specified in the attached solicitation.** (August 31, 2020 at 12:00 P.M)

The County will not accept bids it receives by fax or email. All faxed or emailed bids will be returned to the bidder.

**Please note:**

- The **Name and Signature Requirements** sections located on the Solicitation, Bid, and Award Sheet. **Failure to sign your bid as required may be cause for your bid to be deemed nonresponsive.**
- The **Mandatory Bid Submissions** on Page 16. The checked items must be submitted with your bid. **Failure to submit the mandatory bid submissions may be cause for your bid to be deemed nonresponsive.**
- The **Method of Award** stated in this solicitation on Page 12.

**TABLE OF CONTENTS**

**DIVISION 0: BIDDING REQUIREMENTS AND CONDITIONS OF THE CONTRACT**

|  | Page                             |
|--|----------------------------------|
| INSTRUCTIONS TO BIDDERS.....   | 6                                |
| DELEGATION OF CONTRACT ADMINISTRATOR .....   | 19                               |
| BID TO MONTGOMERY COUNTY.....  | 20                               |
| (includes Minority Owned Business Addendum to General Conditions of Contract Between County and Contractor)                              |                                  |
| BID BOND .....   | 34                               |
| FIXED PRICE CONSTRUCTION CONTRACT BETWEEN OWNER AND CONTRACTOR.....  | 35                               |
| PERFORMANCE BOND.....  | 53                               |
| PAYMENT BOND.....  | 59                               |
| MANDATORY INSURANCE REQUIREMENTS .....   | 64                               |
| PREVAILING WAGE REQUIREMENTS FOR CONSTRUCTION CONTRACT ADDENDUM TO THE GENERAL CONDITIONS OF CONTRACT BETWEEN COUNTY AND CONTRACTOR..... | 67                               |
| Montgomery County – Building Construction.....   |                                  |
| GENERAL CONDITIONS OF CONSTRUCTION CONTRACT.....   | VGCofCC 11072018 Section 00 7200 |
| MASTER SCHEDULE AND CRITICAL CONTRACT COMPLETION PERIODS .....   | Section 00 8000                  |

**DIVISION 01: GENERAL REQUIREMENTS**

|        |   |          |
|--------|---|----------|
| 011100 | Summary of Work .....                   | 011100-1 |
| 011150 | Construction Phasing Requirements ..... | 011150-1 |
| 012100 | Allowances.....                         | 012100-1 |
| 013523 | Contractors' Safety Requirements .....  | 013523-1 |
| 017700 | Closeout Procedures .....               | 017700-1 |

**DIVISION 14: CONVEYING EQUIPMENT**

|        |                           |          |
|--------|---------------------------|----------|
| 142400 | Hydraulic Elevators ..... | 142400-1 |
|--------|---------------------------|----------|

**DRAWINGS**

|    |                                   |   |
|----|-----------------------------------|---|
| A  | Existing Hoistway Plan.....       | 1 |
| A1 | New Hoistway Plan .....           | 2 |
| B  | Existing Machine Room Plan.....   | 3 |
| B1 | New Machine Room Plan .....       | 4 |
| C  | Existing Hoistway Elevation ..... | 5 |
| C1 | New Hoistway Elevation.....       | 6 |
| D  | Existing Landing Elevation .....  | 7 |
| D1 | New Landing Elevation .....       | 8 |

END OF TABLE OF CONTENTS



INSTRUCTIONS TO BIDDERS

---

TABLE OF CONTENTS

1. DEFINITIONS
  2. BIDDER'S REPRESENTATIONS
  3. BID DOCUMENTS
  4. BIDDING PROCEDURES
  5. CONSIDERATION OF BIDS
  6. QUALIFICATION OF CONTRACTORS
  7. PERFORMANCE BOND AND LABOR AND MATERIAL PAYMENT BOND
  8. LIQUIDATED DAMAGES FOR FAILURE TO COMPLETE ON TIME
  9. FORM OF CONTRACT BETWEEN OWNER AND CONTRACTOR
  10. SALES TAX REQUIREMENT
  11. BID PROTEST
  12. MANDATORY SUBMISSIONS
-

IFB #1109382  
ARTICLE 1

DEFINITIONS

- 1.1 Bid Documents include the Advertisement, Invitation for Bids, Instructions to Bidders, the Bid Form, other sample Bidding and contract forms and the proposed Contract Documents including any Addenda issued prior to receipt of Bids.
- 1.2 All definitions set forth in the General Conditions of Construction Contract or in other Contract Documents are applicable to the Bid Documents.
- 1.3 Addenda are written on graphic instruments issued by the Owner prior to the opening of Bids, which interpret the Bid Documents by additions, deletions, clarifications or corrections.
- 1.4 A Bid is a complete and properly signed Bid to do the Work or designated portion thereof for the sums stipulated therein supported by data called for by the Bid Documents.
- 1.5 Base Bid is the sum stated in the Bid for which the Bidder offers to perform the Work described in the Bid Documents, to which Work may be added or deducted for sums stated in Alternate Bids.
- 1.6 An Alternate Bid (or Alternate) is an amount stated in the Bid to be added to (add Alternate) or deducted from (deduct Alternate) the amount of the Base Bid if the Owner decides to accept a corresponding change in either the project scope, the amount of construction to be completed, the products, materials, equipment, systems or installation methods described in the Bid Documents and Contract Documents.
- 1.7 Unit Prices refer to the amounts stated in the Bid and selected by the Owner for incorporation into the Contract Documents that includes all direct labor and materials costs, payroll burden, relocation of stockpiled materials as necessary, indirect job costs such as insurance, bonds, coordination, engineering, permits, cleanup, tools, profit, and overhead (which includes office overhead and site-specific overhead and general conditions), subcontractor profit and overhead, and all other costs necessary to complete the Work. Unit Prices include all costs for the work as defined in the General Conditions of Construction Contract. Unit Prices as stated shall remain in effect through the end of the Contract warranty period.
- 1.8 A Bidder is one who submits a Bid for a prime contract with the Owner for the Work described in the proposed Contract Documents.
- 1.9 A Sub-Bidder is one who submits a Bid to a Bidder for materials or labor for a portion of the work.
- 1.10 The "Owner" is Montgomery County, Maryland.

ARTICLE 2

BIDDER'S REPRESENTATIONS

- 2.1 Each Bidder in submitting a Bid represents to the Owner as follows that:

IFB #1109382

- a. The Bidder has read and understands the Bid Documents and the Bid is made in accordance therewith.
- b. The Bidder has visited the site and is familiar with the local conditions under which the Work is to be performed.
- c. The Bid is based upon the materials, systems and equipment described in the Bid Documents without exceptions.
- d. The Bidder declares: (i) that the only person, firm or corporation, or persons, firms or corporations, that has or have any interest in this Bid or in the contract or contracts proposed to be taken, is or are the undersigned; and (ii) that this Bid is made without any connection or collusion with any person, firm or corporation making a Bid for the same Work.

ARTICLE 3

BID DOCUMENTS

3.1 COPIES

- 3.1.1 Bidders may obtain from the Owner complete sets of the Bid Documents in the number and for the sum, if any, stated in the Advertisement or Notice to Vendors.
- 3.1.2 Complete sets of Bid Documents shall be used in preparing Bids. Neither the Owner nor the Architect assumes any responsibility for errors or misinterpretations resulting from the use of incomplete sets of Bid Documents.
- 3.1.3 The Owner or Architect in making copies of the Bid Documents available on the above terms, do so only for the purpose of obtaining Bids on the Work and do not confer a license or permission for any other use.

3.2 INTERPRETATION OR CORRECTION OF BID DOCUMENTS

- 3.2.1 Bidders must promptly notify the Owner in writing of any ambiguity, inconsistency or error that they may discover upon examination of the Bid Documents or of the site and local conditions. The Bidder must send a copy of the written notification to the Architect.
- 3.2.2 **Bidders requiring clarification or interpretation of the Bid Documents must make a written request to the Owner that must reach the Owner at least ten days prior to the date for receipt of Bids. The Bidder must send a copy of the written request to the Architect.**
- 3.2.3 Any interpretation, correction or change of the Bid Documents will be made by Addendum. Interpretations, corrections or changes of the Bid Documents made in any other manner will not be binding, and Bidders must not rely upon such interpretations, corrections, or changes.

3.3 BACKGROUND/INTENT

- 3.3.1 This project consists of a full renovation of the elevators at Strathmore Mansion.**
- 3.3.2 A typical schedule of the hours of operation for the facility is: Weekdays 7:00 a.m. to 5:00 p.m. Work outside these hours, including weekends and holidays, must be approved in advance by the Owner.**
- 3.4 SUBSTITUTIONS**
- 3.4.1 The materials, products and equipment described in the Bid Documents establish a standard of required function, dimension, appearance and quality to be met by any proposed Substitution.**
- 3.4.2 No Substitution will be considered unless written request for approval has been submitted by the Bidder and has been received by the Owner at least ten days prior to the date for receipt of Bids. A copy of said written request shall be sent to the Architect. Each such request must include the name of the material or equipment for which it is to be substituted and a complete description of the proposed Substitution including drawings, cuts, performance and test data and any other information necessary for an evaluation. A statement setting forth any changes in other materials, equipment or work that incorporation of the Substitution would require shall be included. The burden of proof of the merit of the proposed Substitution is upon the Bidder. The Owner's decision of approval or disapproval of a proposed Substitution shall be final.**
- 3.4.3 If the Owner approves any proposed Substitution, the approval will be set forth in an Addendum. Bidders must not rely upon approvals made in any other manner.**
- 3.5 ADDENDA**
- 3.5.1 Addenda will be posted on the Montgomery County Procurement website and mailed, faxed and/or sent electronically (e-mail) to all who are known by the Owner to have received a complete set of Bid Documents.**
- 3.5.2 NOT APPLICABLE**
- 3.5.3 In the event that an Addendum is issued, all unchanged terms and conditions will remain in effect unless they are specifically changed by the Addendum. Bidders must acknowledge receipt of Addenda, to the place designated, and prior to the hour and date specified in the Solicitation (as amended) for receipt of Bids. BIDDERS WHO DO NOT TIMELY ACKNOWLEDGE RECEIPT OF ADDENDA BY ONE OF THE FOLLOWING METHODS MAY BE REJECTED:**
- a. By returning one signed copy of the Addendum.**
  - b. By acknowledging receipt of the Addendum on at least one signed copy of the Bid submitted by the Bidder.**
  - c. By stating that the Addendum is acknowledged in a signed letter that refers to the Solicitation and Addenda numbers.**

IFB #1109382

- 3.5.4 A waiver of the requirement to timely acknowledge receipt of the Addenda, as set forth in Article 3.5.3, may be granted by the Director, Office of Procurement, if it is deemed to be in the County's best interest. No waiver may be granted, however, until the Bidder certifies in writing that the Bidder will be bound by any substantive changes made by the Addenda to the terms of the Solicitation.
- 3.5.5 The Bidder must comply with the requirements of Article 4.4 if an Addendum had been issued and the Bidder wants to change a Bid that has already been submitted prior to the official opening of the Bids.
- 3.5.6 ALL SIGNATURES ON BIDS, ADDENDA, OR RELATED CORRESPONDENCE MUST BE BY PERSONS WHO ARE AUTHORIZED TO BIND THE BIDDERS CONTRACTUALLY.

ARTICLE 4

BIDDING PROCEDURES

4.1 FORM AND STYLE OF BIDS

- 4.1.1 Bids must be submitted in duplicate on the forms provided in the Bid Documents.
- 4.1.2 All blanks on the Bid document must be filled in.
- 4.1.3 The Base Bid must be expressed both numerically and written out in words. In case of a discrepancy between the numeric and word figures, the amount written out in words will govern.
- 4.1.4 Any interlineations, alterations, erasures, or other changes to Bids must be initialed by the signer of the Bid before the Bid is submitted.
- 4.1.5 All requested Alternates must be included in the Bid.
- 4.1.6 Where there are two or more major items of work for which separate quotations have been requested, Bidder may state in the Bid the refusal to accept less than whatever combination of the items are stipulated in the Bid.
- 4.1.7 Bidder must make no additional stipulations on the Bid form nor qualify the Bid in any other manner.
- 4.1.8 Each copy of the Bid must include the correct and full legal name of the Bidder and a statement of whether the Bidder is a sole proprietor, a general or limited partnership, a corporation, a limited liability corporation, a limited liability partnership, or any other legal entity. Signatures of offerors and contractors must be in their correct legal form and must not be abbreviated to common usage or trade name form. All signatures must be made by an authorized officer, partner, manager, member, or employee. The signing of an offer or a contract is a representation by the person signing that the person signing is authorized to do so on behalf of the Bidder or contractor. A Bid submitted by an agent must attach a current Power of Attorney that certifies the agent's authority to bind the Bidder. Bids and contracts that are not signed in compliance with these requirements are voidable at the

option of the County.

## 4.2 BID GUARANTEE

**4.2.1** If so stipulated in the Invitation for Bids, each Bid must be accompanied by a Bid Bond or Bid Security in the required form and amount pledging that the Bidder will enter into a Contract with the Owner within ten (10) days of the receipt of the Contract, on the terms stated in the Bid and will furnish the bonds described in Article 7 covering the faithful performance of the Contract and the payment of all obligations arising thereunder. **Should the Bidder refuse to enter into the Contract or fail to furnish the bonds, the amount of the Bid Bonds or Bid Security may be forfeited to the Owner as liquidated damages, not as penalty.**

**4.2.2** The Bid Bond must be written in the form of AIA Document A310 Bid Bond, or equivalent, and the Attorney In Fact who executes the Bond on behalf of the surety must affix to the Bond a certified and current copy of the current Power of Attorney, see page 34 for a sample Bid Bond. The Bid Security may be in the form of a Cashier's Check, Certified Check, Bank Letter of Credit and be duly executed by the Bidder as a principle, and made payable to Montgomery County, Maryland.

**4.2.3** The Owner has the right to retain the Bid Guarantee until one of the following occurs: (a) the Contract has been executed and the Performance and Payment Bonds have been furnished; or (b) the specified time has elapsed so that Bids may be withdrawn; or (c) all Bids have been rejected.

## 4.3 SUBMISSION OF BIDS

**4.3.1** A Bidder must submit copies of the Bid, the Bid Bond or Bid Security, and all other Bid Documents in a sealed opaque envelope addressed to: Director, Office of Procurement, 255 Rockville Pike, Suite 180, Rockville, Maryland 20850, and must be identified with the Project name, the Bid Number, and the Bidder's name and address. If the Bid is sent by mail, the sealed envelope must be enclosed in a separate mailing envelope with the notation "BID ENCLOSED" on the face of the envelope.

**4.3.2** Bids must be deposited at the designated location prior to the time and date for receipt of Bids indicated in the Invitation for Bids as amended. Bids received after the time and date for receipt of Bids will be returned to the Bidder unopened.

**4.3.3** The Owner will not consider any Bids that are not timely delivered by the Bidder.

**4.3.4** Bids submitted by telephone, telefacsimile, or e-mail are not valid and will not be considered by the Owner.

## 4.4 MODIFICATION OR WITHDRAWAL OF BID

**4.4.1** A Bid must not be modified, withdrawn or canceled by the Bidder for 120 days following the time and date designated for the receipt of Bids, and Bidder so agrees when submitting a Bid.

**4.4.2** Bids submitted prior to the date specified in the Bid Documents may be modified or

IFB #1109382

withdrawn only by the Bidder's written notice to the Owner at the place designated for receipt of Bids and prior to the date on which Bids are due.

- 4.4.3 The Bidder's written notice of withdrawal must be signed by the Bidder.
- 4.4.4 Withdrawn Bids may be resubmitted up to the time designated for the receipt of Bids provided that they are then fully in conformance with the Bid Documents.
- 4.4.5 Bid security must be in the form of a cashiers check, certified check, bank letter of credit or bid bond in the amount of not less than five percent (5%) of the Total Base Bid. Should the Bidder refuse to enter into the Contract or fail to furnish the bonds, the amount of the Bid Bonds or Bid Security may be forfeited to the Owner as liquidated damages, not as penalty.
- 4.4.6 Only a bid from a Certified Small Business with Health Insurance that submits a certificate issued by Montgomery County Department of Health and Human Services at the time of bid submission will received a % price preference that will be utilized to recalculate prices for purpose of the Method of Award process in accordance with the criteria stated under Procurement Regulation 11B.77.01.06; See Procurement Regulations at: [www.montgomerycountymd.gov/PRO/Laws.html](http://www.montgomerycountymd.gov/PRO/Laws.html)

ARTICLE 5

CONSIDERATION OF BIDS

5.1 OPENING OF BIDS

- 5.1.1 Unless stated otherwise in the Advertisement or Invitation for Bids, the properly identified Bids received on time will be opened publicly and will be read aloud.

5.2 REJECTION OF BIDS

- 5.2.1 The Owner has the right to reject any or all Bids and in particular to reject a Bid not accompanied by any required Bid Bond or Bid Security, any other information required by the Bid Documents, or a Bid that is in any way incomplete or irregular in the sole and absolute discretion of the Owner.

5.3 ACCEPTANCE OF BID (AWARD)

- 5.3.1 The Owner has the right to waive any irregularity in any Bid received in accordance with the Montgomery County Procurement Regulations.

**5.3.2 The lowest Bid will be determined by the amount of the lowest Base Bid only.**

- 5.3.3 Unless otherwise expressly stated in the Bid Documents, the award of a Contract under this Invitation for Bids will be made to the lowest responsive Bid submitted by a responsible Bidder based solely upon the Base Bid Price as stated on the Quotation Sheet. The price quoted for the Base Bid must include all necessary costs required to perform the Work specified in the technical specifications. Prices for Alternate items will not be considered in a determination of award. Bidders are hereby notified that the Montgomery County Code



Sections 11B-1 and 11B-9, are amended by the Reciprocal Local Preference and is applicable to this solicitation:

[https://www.montgomerycountymd.gov/council/resources/files/lms/bill/2014/Signed/pdf/1386\\_934\\_Signed\\_04062017.pdf](https://www.montgomerycountymd.gov/council/resources/files/lms/bill/2014/Signed/pdf/1386_934_Signed_04062017.pdf)

- 5.3.4 The Owner shall have the right to accept Alternates in any order or combination.
- 5.3.5 The Owner will accept or reject any or all Bids on any or all items within 120 days after the date set for opening of the Bids.
- 5.4 POSTING OF THE PROPOSED CONTRACT AWARDEE
  - 5.4.1 The Montgomery County Procurement Regulations are applicable to this solicitation and any contracts awarded pursuant to this solicitation. Of particular importance is the fact that the notice of a decision to make an award, under Section 3.2.2 of the Montgomery County Procurement Regulations, will be accomplished by a posting of the proposed contract awardee on a public list in the Office of Procurement, Rockville Center, 255 Rockville Pike, Suite 180, Rockville, Maryland 20850. The time period for filing a protest, as provided in Section 14.1.2 of the Montgomery County Procurement Regulations, commences THE NEXT DAY FOLLOWING the date of the posting.
  - 5.4.2 It is the responsibility of the Bidders to keep informed of the current status of any proposed awardees for contracts in which they are interested. See Section 3.2.2 of the Montgomery County Procurement Regulations.

## ARTICLE 6

### QUALIFICATION OF CONTRACTORS

- 61 The Owner may make such investigations as it deems necessary to determine the ability of the Bidder to perform the Work, and the Bidder shall furnish to the Owner all such information and data for this purpose as the Owner may request. The Owner may visit any prospective Contractor's place of business or consider other factors necessary to perform the Work. The Owner reserves the right to reject the Bid of a Bidder that has previously failed to perform properly or to complete in a timely manner, or whose proposed subcontractors, suppliers, or surety have similarly failed to perform properly, or timely on contracts of similar nature, or if investigations show the Bidder unable to perform the requirements of the Contract.
- 62 Upon request, Bidders that have not previously qualified successfully with the Owner for work comparable to that contemplated in this solicitation or that have not performed comparable work for the Owner within the last two years must furnish the following proof of qualifications to perform the Work specified under oath. Bidders must furnish a written description of comparable work performed by the Bidder within the previous five years indicating the location, construction contract, scope, contract sum, type of construction, name and address of owner and architect, date completed and construction period in number of days. Failure to submit the required information will be sufficient cause for the Owner to reject the Bid. Bidders may be required to furnish additional information as proof of qualification subsequent to opening of the Bids and must do so within five (5) days of the



request.

- 63 Bidders must be licensed as required by Maryland law, as set forth in Md. Code Ann., Bus. Reg. §17-601, et seq. (2004 Repl. Vol.), as amended. For additional information contact the State License Bureau, 301 West Preston Street, Baltimore, MD 21201.
- 64 Subsequent to opening of Bids, and upon the Owner's request, Bidders must furnish a current condensed net worth statement and references for verification of financial responsibility. Failure to submit the information within five (5) calendar days of the Owner's request may be sufficient cause for the Owner to consider the Bidder as non-responsive.
- 65 Montgomery County Prevailing Wage Law is applicable to this Solicitation. The Prevailing Wage Law is contained in Chapters 11B-33C, and 20-75 of the Montgomery County Code effective 07/01/2009.

ARTICLE 7

PERFORMANCE BOND AND LABOR AND  
MATERIAL PAYMENT BOND

- 7.1 REQUIRED BONDS - Performance and Labor and Material Payment Bonds will not be required for Bids under \$50,000.
- 7.1.1 Prior to the award of the Contract, the successful Bidder must furnish bonds covering the faithful performance of the Contract and the payment of all labor and material arising thereunder in the amount of 95% of the Contract, with a corporate surety or sureties authorized to do business in the State of Maryland. The premiums must be paid by the Bidder.

The Bidder must furnish separate Bid, performance and payment bonds to the Owner in the forms prescribed in the Bid or Proposal Documents and Article 17 of the General Conditions of Construction Contract. The performance and payment bonds must set forth a penal sum in an amount not less than 95% of the Contract Sum. Each bond furnished by the Bidder must incorporate by reference the terms of this Contract as fully as though they were set forth verbatim in the bonds. The penal sum of both the performance and payment bonds will be automatically increased in the amount of any increase to the Contract Sum. The performance and payment bonds furnished by the Bidder must be in the forms prescribed in the Bid or Proposal Documents and Article 17 of the General Conditions of Construction Contract. The Surety must be a corporate Surety authorized to do business in the State of Maryland and acceptable to the Owner. While determining Surety acceptability, the Owner may make such investigations as he deems necessary to determine the ability of the Bidder's Surety to perform its duties and obligations and the Bidder shall furnish to the Owner, within five (5) days of Owner request, all such data and information for this purpose as the Owner may request. The Owner reserves the right, in its absolute discretion and for any reason, to accept or reject any Surety proposed by the Bidder.

Failure to submit information in a timely manner as indicated may be cause to not award Contract.

7.2 TIME OF DELIVERY AND FORM OF BONDS

- 7.2.1 The Bidder must deliver the required bonds to the Owner prior to the award and execution of the Contract by the Owner.
- 7.2.2 Unless otherwise specified in the Bid Documents, the bonds must be written in the form as set forth on pages **53 and 59**, and the Performance and Payment Bonds must comply with or exceed requirements set forth in Md. Code Ann., State Fin. & Proc. §17-101 through §17-111 (2006 Repl. Vol.).
- 7.2.3 The Bidder must require the person who executes the required bonds on behalf of the surety to affix thereto a certified and current copy of the Power of Attorney authorizing the person's signature.

## ARTICLE 8

### LIQUIDATED DAMAGES FOR FAILURE TO COMPLETE ON TIME

- 8.1 The time in which the Contractor agrees to complete the Work is the essence of the Contract and failure to complete the Work within the time specified will entitle the Owner to, and it will, deduct and retain from any monies due the Contractor, liquidated damages in the amount of **Five Hundred Dollars (\$500.00) per day**, for each calendar day in excess of the time specified by the Bid Documents for Substantial Completion of the Work. The sum shall not be considered as a penalty but as a sum mutually agreed upon as the ascertained damages suffered by the Owner because of the delay. Official starting date shall be as stated in the Notice to Proceed.
- 8.2 Requests for an extension of the completion time due to strikes, lack of materials, or any condition over which the Contractor has no control will be reviewed by the Owner after written application is made for a time extension to the Owner and Architect Any request for an extension of time is to be made immediately upon occurrence of conditions that, in the opinion of the Contractor, warrant the extension, with reasons clearly stated and detailed proof given for all delays, and must be made in writing to the Owner and Architect. No time extension will be allowed except by formal approval of the Owner.

## ARTICLE 9

### FORM OF CONTRACT BETWEEN OWNER AND CONTRACTOR

- 9.1 FORM TO BE USED
- 9.1.1 Unless otherwise provided in the Bid Documents, the Contract for the Work will be written on the Standard Form, "Fixed Price Construction Contract Between Owner and Contractor" included with this IFB.

## ARTICLE 10

### SALES TAX REQUIREMENT

- 10.1 Bidders are required to include sales tax in their Bids. See Md. Code Ann., Tax-Gen. §11-220 (2004 Repl. Vol.).

ARTICLE 11

BID PROTEST

- 11.1 All protests made pursuant to this solicitation must be in writing and delivered to the Director, Office of Procurement, (a) within ten (10) days after the Director, Office of Procurement publicly posts the Contract Award, if the Bidder seeks as a remedy the award of the Contract or costs under 11B-36(h) of the Montgomery County Code, or (b) before the submission date for bids, if the bidder seeks as a remedy the cancellation or amendment of the solicitation. Each protest must contain a protest filing fee in the amount of \$500 (US currency); if the fee is paid by check, then the check must be made out to "Montgomery County Government." The Director, Office of Procurement, may return the filing fee to the protesting bidder, if the protest is sustained. The Director, Office of Procurement must dismiss any protest not timely received.
- 11.2 Only a Bidder who is "aggrieved" may file a protest. Aggrieved means that the bidder who is filing the protest may be eligible for an award of the Contract if the protest is sustained (e.g., a fourth ranked bidder is not aggrieved unless the grounds for a protest, if sustained, would disqualify the top three ranked Bidders or would require that the solicitation be reissued).
- 11.3 Each protest must contain the following: identification of the solicitation; the name, address and telephone number of the protesting offeror; a statement supporting that the Bidder is aggrieved; and specification of all grounds for the protest, including submission of detailed facts and all relevant documents; citation to relevant language in the solicitation, regulations, or law relied upon; and all other matters that the Bidder contends support the protest. Both the burden of production of all relevant evidence, data, and documents, and the burden of persuasion to support the protest are on the Bidder making the protest.

ARTICLE 12

MANDATORY SUBMISSIONS

**12.1 MANDATORY BID SUBMISSIONS:**

The following checked items (each of which are described in detail in Mandatory, General and Special Terms and/or Specifications or Scope of Work Sections of IFB), are to be included with the Bid submission:

- Bid Guarantee, 5%. (Page 34).
- BID (Pages 20-25).
- Unit Prices (if applicable).
- Add & Deduct Alternates (if applicable).

**The Bidder's Failure to submit all of the information as set forth above will result in the mandatory rejection of the Bid.**

**12.2 OPTIONAL BID SUBMISSIONS:**

Minority, Female, Disabled Person Subcontractor Performance Plan (to ensure a Contract

can move forward as a result of this solicitation, you are encouraged to submit the plan with your Bid).

**Local Business Subcontract Plan**

[www.montgomerycountymd.gov/PRO/Resources/Files/SolForm/PMMD-192.pdf](http://www.montgomerycountymd.gov/PRO/Resources/Files/SolForm/PMMD-192.pdf)

**12.3 PRE- AWARD SUBMISSIONS**

The following checked items (each of which are described in detail in Mandatory, General and Special Terms and/or Specifications or Scope of Work Sections of IFB) must be provided upon request from the three (3) apparent low bidders within five (5) calendar days of the Owner's request.

- |                                     |   |                                     |                                   |
|-------------------------------------|---|-------------------------------------|-----------------------------------|
| <input type="checkbox"/>            | <b>Current Manufacturer catalog(s)</b>  | <input type="checkbox"/>            | <b>Price List(s)</b>              |
| <input checked="" type="checkbox"/> | <b>Bidder Qualifications<br/>See 6.1 and 6.2</b>  | <input checked="" type="checkbox"/> | <b>Financial Data<br/>See 6.4</b> |
| <input type="checkbox"/>            | <b>Installation Schedules</b>   | <input type="checkbox"/>            | <b>Personnel Data</b>             |
| <input checked="" type="checkbox"/> | <b>References</b>   | <input type="checkbox"/>            | <b>Plans or Drawings</b>          |
| <input checked="" type="checkbox"/> | <b>Itemized construction cost breakdown<br/>See Itemized Construction Cost Sheet (Page 25 )</b>   |                                     |                                   |
| <input checked="" type="checkbox"/> | <b>Central Vendor Registration, including submission of Federal Form W-9.<br/>First-time vendors must register at <a href="http://www.mcipcc.net">www.mcipcc.net</a>.</b> |                                     |                                   |

Failure to submit information as indicated within the specified time period may be sufficient cause for rejection to consider the Bidder as Non-Responsive.

**12.4 AWARD SUBMISSIONS:**

The following checked items (each of which are described in detail in Mandatory, General and Special Terms and/or Specifications or Scope of Work Sections of IFB), must be submitted within ten (10) days after the date of the Owner's written notification of Intent to Award a Contract:

- |                                     |   |                                     |  |
|-------------------------------------|---|-------------------------------------|--|
| <input checked="" type="checkbox"/> | <b>Performance Bond<br/>(Required only for Bids<br/>in excess of \$50,000.00)</b> | <input checked="" type="checkbox"/> | <b>Labor and Material<br/>Payment Bond<br/>(Required only for Bids in excess of<br/>\$50,000.00)</b> |
| <input checked="" type="checkbox"/> | <b>Certificate of Insurance</b>   |                                     |  |
| <input checked="" type="checkbox"/> | <b>Minority Business Program &amp; Offerors Representation</b>                    |                                     |  |

IFB #1109382

X Minority-Owned Business Addendum to the General Conditions of Contract  
Between County and Contractor and its companion document entitled Minority,  
Female, Disabled Person Subcontractor Performance Plan

**Others: as follows:** \_\_\_\_\_

Failure to submit information in a timely manner as indicated may be cause to rescind  
Intent to Award Contract.

END OF INSTRUCTIONS TO BIDDERS

IFB #1109382  
DELEGATION OF CONTRACT ADMINISTRATOR

DELEGATION OF CONTRACT ADMINISTRATOR RESPONSIBILITY AND AUTHORITY. The Montgomery County Director, Department of General Services hereby delegates to the person identified below the responsibility and authority to perform the functions of the Contract Administrator for this Contract.

Gregory Boykin, Chief  
Montgomery County Department of General Services  
Division of Facility Management  
1301 Seven Locks Road  
Rockville, MD 20854  
(240) 777-5359

This delegation authorizes the Contract Administrator the functions as assigned in the General Conditions of Construction Contract and in the applicable regulations and procedures, commencing on the date that the Contract is signed by the Director, Office of Procurement, and terminating on the date contractor performance is completed (including final payment) or terminated.

Unless the Montgomery County Director, Department of General Services, changes this delegation of authority in writing, no other person is authorized to perform the functions of the Contract Administrator for this particular Contract.

**BID TO MONTGOMERY COUNTY**

Office of Procurement  
Rockville Center  
255 Rockville Pike, Suite 180  
Rockville, Maryland 20850

**Re: Strathmore Mansion Elevator Renovation**

Dear Sir:

1. The Bidder has carefully examined and understands the Drawings, Instructions to Bidders, and the Specifications including all Addenda.
2. The Bidder has carefully examined all of the Contract Documents and all modifications thereto.
3. **The Bidder understands that the award will be based upon the lowest BASE BID only.**
4. The Bidder understands that Alternate Bid items may be accepted or rejected in any order at the Owner's discretion.
5. The Bidder understands that the Owner reserves the right to correct all mathematical errors in the Bid.
6. The Bidder understands that the failure of a Bidder to submit all of the Unit Prices, and all add & deduct Alternates will require mandatory rejection of the Bid.
7. **The Bidder understands that the successful Bidder will be required to commence work within ten (10) calendar days after the date of Notice to Proceed for Phase #1 (60 calendar days) and shall Substantially Complete the Contract within 140 calendar days of Notice to Proceed for Phase #2. Total of 200 calendar day**
8. **s from Notice to Proceed No. one to Substantially Completion.**
9. The Bidder agrees that liquidated damages will be paid in the sum of Five Hundred Dollars (\$500.00) for each day of unexcused delay beyond the date set forth above for Substantial Completion.
10. The Bidder understands that the failure of a Bidder to submit the Bid Guarantee or Base Bid will require mandatory rejection of the Bid.
11. **Allowance for work to be determined by Owner in the amount of \$25,000 (General Conditions – Article 1.1.4)**

Based on the foregoing representations, the Bidder hereby offers and agrees to do all the Work called for, in accordance with the Contract and Bid documents, if the Bid is accepted, for the following amount:

**BASE BID: \_\_\_\_\_ DOLLARS (Written)**

**\$ \_\_\_\_\_ (Numbers)**

**Name of Firm: \_\_\_\_\_**

**SCHEDULE OF UNIT PRICES**

**UNIT PRICES**

**MANDATORY UNIT PRICES:** Unit prices are used for materials or services that will be added to or deducted from the Contract by Change Order in the event the quantities of work required by the Contract Documents are increased or decreased. The unit prices listed in the "Schedule of Mandated Unit Prices" are applicable to all work in this project involving extra materials/services performed by the General Contractor or his subcontractors and /or credits to the Owner for materials/services deleted from the project. Mandatory Unit price includes all costs for the work as defined in the General Conditions of Contract including subcontractor profit and overhead. General Contractor mark-up is to be applied per the General Conditions. Prices as stated shall remain in effect through the end of the Contract warranty period.

The undersigned acknowledges the Mandatory unit price values are part of this bid proposal and agrees to add or delete items for the unit prices identified when requested by the County.

**END OF UNIT PRICES**

**Name of Firm:** \_\_\_\_\_



**ALTERNATES**

**ALL ALTERNATES MUST BE BID**

Having understood that failure of a Bidder to Bid all add and deduct Alternates will require mandatory rejection of the Bid.

A. ADD ALTERNATE – ELEVATOR NUMBER 1 \$ \_\_\_\_\_

Redrill wellhole, remove and properly dispose of excess excavated material and install steel casing as specified in Section 142400 – 2.5,G.

A. ADD ALTERNATE – ELEVATOR NUMBER 2 \$ \_\_\_\_\_

Redrill wellhole, remove and properly dispose of excess excavated material and install steel casing as specified in Section 142400 – 2.5,G.

**END OF ALTERNATES**

OWNER REQUESTED OPTIONAL WORK

Owner reserves the right to contract with the contractor to perform repair on “as-needed basis” for the project. This work is neither part of the work nor the warranty work. The prices listed in this Owner Requested Optional Work by the contractor are the maximum amounts that can be charged by the contractor for any Optional Work. The Owner reserves the right to negotiate lower prices for Optional Work based on then-prevailing industry standards.

**1. THE NORMAL WORK DAY AND NORMAL WORK WEEK WILL BE:**

WORK DAY FROM 7:30 A.M. TO 4:00 P.M.  
 WORK WEEK FROM MONDAY THRU FRIDAY .

**2. OVERTIME RATE:**

CALL BACK FOR ONE MAN AFTER NORMAL WORK HOURS MONDAY THRU FRIDAY AND ALL DAY SATURDAY:

**3. DOUBLE TIME RATE:**

CALL BACK FOR ONE MAN ALL DAY SUNDAY AND HOLIDAYS. SERVICE / REPAIR CREW AFTER NORMAL WORK HOURS MONDAY THRU FRIDAY AND ALL DAY SUNDAYS AND HOLIDAYS.

**4. HOURLY LABOR RATES: HOURLY LABOR RATES FOR ADDITIONAL**

WORK WHICH MAY BE REQUESTED BY THE OWNER, IF THE NEED SHOULD ARISE IN ACCORDANCE WITH THE SPECIFICATION. THE HOURLY RATES FOR SUCH WORK SHALL BE INCLUSIVE OF ALL COSTS; i.e., DIRECT LABOR, GENERAL AND ADMINISTRATIVE OVERHEAD, TAXES, BONDS, INSURANCE, PROFIT AND THE COST OF THE EQUIPMENT THAT IS NORMAL AND CUSTOMARY (TRUCKS, TOOLS, ETC).

- STRAIGHT TIME – MECHANIC \$ \_\_\_\_\_ /PER HR.
- STRAIGHT TIME – HELPER \$ \_\_\_\_\_ /PER HR.
- (PREMIUM OVERTIME – MECHANIC \$ \_\_\_\_\_ /PER HR.
- (PREMIUM) OVERTIME – HELPER \$ \_\_\_\_\_ /PER HR.
- (PREMIUM) DOUBLE TIME – MECHANIC \$ \_\_\_\_\_ /PER HR.
- (PREMIUM) DOUBLE TIME – HELPER \$ \_\_\_\_\_ /PER HR.

**Name of Firm:** \_\_\_\_\_

BID TO MONTGOMERY COUNTY (cont'd)

Receipt is acknowledged of Addenda and such is included in this BID as follows:

Addenda No. \_\_\_\_\_ Date \_\_\_\_\_  - Mark here if there were no addenda.

SUBMITTED BY:

FIRM: \_\_\_\_\_

NAME: \_\_\_\_\_

TITLE: \_\_\_\_\_

ADDRESS: \_\_\_\_\_

PHONE: \_\_\_\_\_

FAX NO.: \_\_\_\_\_

E-MAIL ADDRESS: \_\_\_\_\_

SIGNATURE: \_\_\_\_\_

NOTE: NO BIDS WILL BE ACCEPTED UNLESS SUBMITTED IN INK OR TYPEWRITTEN. All signatures on offers, amendments, or related correspondence must be by persons who are authorized to bind the offerors contractually.

**NAME AND SIGNATURE REQUIREMENTS FOR BIDS AND CONTRACTS**

The correct and full legal business name of the entity involved must be used on bids received and on contract(s) issued as a result of this solicitation. A trade name, i.e., a shortened or different name under which the firm does business, must not be used when the full legal name is different. Corporations must have names that comply with State law, which requires a suffix indicating the corporate status of that business (e.g., Inc., Incorporated, etc.). Trade names may be indicated by individuals or corporations with the individual or corporate name followed by "t/a" (trading as) or "d/b/a" (doing business as), respectively.

The signature on the bid, contract, amendment, or related correspondence must conform to the following: All signatures must be made by an authorized officer, partner, manager, member, or employee. The signing of an offer or a contract is a representation by the person signing that the person signing is authorized to do so on behalf of the offeror or contractor.

**ITEMIZED CONSTRUCTION COST**

This information must be provided from the three (3) apparent low bidders within five (5) calendar days of the Owner's request.

| <u>DIVISION</u>                    | <u>AMOUNT</u>             |
|------------------------------------|---------------------------|
| 1. GENERAL REQUIREMENTS            | \$ _____                  |
| 2. EXISTING CONDITIONS             | \$ N/A _____              |
| 3. CONCRETE                        | \$ N/A _____              |
| 4. MASONRY                         | \$ N/A _____              |
| 5. METALS                          | \$ N/A _____              |
| 6. WOOD, PLASTICS, AND COMPOSITES  | \$ N/A _____              |
| 7. THERMAL AND MOISTURE PROTECTION | \$ N/A _____              |
| 8. OPENINGS                        | \$ N/A _____              |
| 9. FINISHES                        | \$ N/A _____              |
| 10. SPECIALTIES                    | \$ N/A _____              |
| 11. EQUIPMENT                      | \$ N/A _____              |
| 12. FURNISHINGS                    | \$ N/A _____              |
| 13. SPECIAL CONSTRUCTION           | \$ N/A _____              |
| 14. CONVEYING EQUIPMENT            | \$ _____                  |
| 15. MECHANICAL                     | \$ N/A _____              |
| 16. FIRE SUPPRESSION               | \$ N/A _____              |
| 17. PLUMBING                       | \$ N/A _____              |
| 18. ELECTRICAL                     | \$ N/A _____              |
| 19. ALLOWANCE                      | \$ <b>25,000.00</b> _____ |

---

TOTAL ITEMIZED CONSTRUCTION COST \$ \_\_\_\_\_

**IFB #1109382**  
**MINORITY BUSINESS PROGRAM & OFFEROR'S REPRESENTATION**

It is the policy of the County to recruit actively, minority-owned businesses to provide goods and services to perform governmental functions pursuant to Section 11B-57 of the County Code. Minority-owned businesses are described in County law as Minority/Female/Disabled Person owned businesses (MFD). MFD businesses include certain non-profit entities organized to promote the interests of persons with a disability demonstrating (on a contract by contract basis) that at least 51% of the persons used by the non-profit entity to perform the services or manufacture the goods contracted for by the County, are persons with a disability. MFD firms also include those firms that are 51% owned, controlled and managed by one or more members of a socially or economically disadvantaged minority group, which include African Americans who are not of Hispanic origin, Hispanic Americans, Native Americans, Asian Americans, Women and Mentally or Physically Disabled Persons.

Section 7 - "Minority Contracting", Montgomery County Procurement Regulations specifies the procedure to be followed and will govern the evaluation of offers received pursuant to this solicitation. A copy of Section 7 of the Procurement Regulations is available upon request.

Prior to awarding contracts with a value of \$50,000 or more, a prospective Contractor must demonstrate that a minimum percentage of the overall contract value as set by the County, will be subcontracted to certified MFD businesses. A decision as to whether the prospective Contractor has demonstrated a good faith effort to meet this subcontracting requirement will be made by the Director, Office of Procurement, or his/her designee, who may waive this requirement.

A sample of the MFD Report of payment Received is attached. This form is mailed to the MFD Subcontractor to complete for documentation of payment by the Prime Contractor. It is not to be completed by the Prime Contractor nor submitted with the MFD Subcontractor Performance Plan.

The Director, Office of Procurement, or his /her designee determines whether a waiver of MFD subcontracting would be appropriate, under Section 7.3.3.5 of the Procurement Regulations.

For further information regarding the MFD Business Program, please contact the MFD Program Manager, Division of Business Relations and Compliance at (240) 777-9912.

---

Offerors are encouraged (but not required) to complete the following:

I hereby represent that this is a Minority Business firm as indicated below (CIRCLE ONE):

|                  |                   |                 |
|------------------|-------------------|-----------------|
| AFRICAN AMERICAN | ASIAN AMERICAN    | DISABLED PERSON |
| FEMALE           | HISPANIC AMERICAN | NATIVE AMERICAN |

Attach one of the following certification documents from: Maryland Department of Transportation (MDOT); Virginia Small, Women & Minority-Owned Business; Federal SBA 8(a); MD/DC Minority Supplier Development Council, Women's Business Enterprise National Council; or City of Baltimore.

## IFB #1109382

### Minority-Owned Business Addendum to General Conditions of Contract Between County and Contractor

- A. This contract is subject to the Montgomery County Code and the Montgomery County Procurement Regulations regarding participation in the Minority-Female-Disabled Person (MFD) procurement program.
- B. Contractor must subcontract a percentage goals listed below of the total dollar value of the contract, including all modifications and renewals, to certified minority owned businesses. The MFD subcontracting goal may be waived under appropriate circumstances by submission of a letter to the Minority Business Program Manager. The letter must explain why a waiver is appropriate. The Director of the Office of Procurement or designee may waive, in whole or in part, the MFD subcontracting goal if the Director determines that a waiver is appropriate under Section 7.3.3.5 of the Montgomery County Procurement Regulations. In determining if a waiver should be granted, the Director may require the Contractor to submit additional information; the Director may require the Contractor to submit some or all of this information on forms approved by the Director.
- For Goals by each purchasing category, please refer to [www.montgomerycountymd.gov/mfd](http://www.montgomerycountymd.gov/mfd)
- C. The attached MFD Subcontractor Performance Plan, which must be approved by the Director, is an integral part of the contract between County and Contractor. In a multi-term contract, Contractor must submit a MFD Subcontract Performance Plan to be in effect for the life of the contract, including any renewal or modification.
- D. Contractor must include in each subcontract with a minority owned business a provision that requires the use of binding arbitration with a neutral arbitrator to resolve disputes between the Contractor and the minority owned business subcontractor. This arbitration provision must describe how the cost of dispute resolution will be apportioned; the apportionment must not, in the judgment of the Director, attempt to penalize a minority owned business subcontractor for filing an arbitration claim.
- E. County approval of the MFD Subcontractor Performance Plan does not create a contractual relationship between the County and the minority owned business subcontractor.
- F. Contractor must notify and obtain prior written approval from the Director regarding any change in the MFD Subcontractor Performance Plan.
- G. Before receiving final payment under this contract, Contractor must submit documentation showing compliance with the MFD Subcontracting Performance Plan. Documentation may include, at the direction of the Director, invoices, copies of subcontracts with minority owned businesses, cancelled checks, affidavits executed by minority owned business subcontractors, waivers, and arbitration decisions. The Director may require Contractor to submit periodic reports on a form approved by the Director. The Director may conduct an on-site inspection for the purpose of determining compliance with the MFD Subcontractor Performance Plan. If this is a multi-term contract, final payment means the final payment due for performance rendered for each term of the contract.

If the Contractor fails to submit documentation demonstrating compliance with the MFD Subcontractor Performance Plan, to the satisfaction of the Director, after considering relevant waivers and arbitration decisions, the Contractor is in breach of this contract. In the event of a breach of contract under this addendum, the Contractor must pay to the County liquidated damages equal to the difference between all amounts the Contractor has agreed under its Plan to pay minority owned business subcontractors and all amounts actually paid minority owned business subcontractors with appropriate credit given for any relevant waiver or arbitration decision. Contractor and County acknowledge that damages which would result to the County as a result of a breach under this addendum are difficult to ascertain, and that the liquidated damages provided for in this addendum are fair and reasonable in estimating the damage to the County of a breach of this addendum by Contractor. In addition, the County may terminate the contract. As the result of a breach under this addendum, The Director of the Office of Procurement must find the Contractor non-responsible for purposes of future procurement with the County for the ensuing three years.

IFB #1109382  
MONTGOMERY COUNTY, MARYLAND  
MINORITY, FEMALE, DISABLED PERSON SUBCONTRACTOR  
PERFORMANCE PLAN

Contractor's

Name: \_\_\_\_\_

Address: \_\_\_\_\_

City: \_\_\_\_\_

State: \_\_\_\_\_

Zip: \_\_\_\_\_

Phone Number: \_\_\_\_\_

Fax Number: \_\_\_\_\_

Email: \_\_\_\_\_

CONTRACT NUMBER/PROJECT DESCRIPTION: \_\_\_\_\_

A. Individual assigned by Contractor to ensure Contractor's compliance with MFD Subcontractor Performance Plan:

Name: \_\_\_\_\_

Title: \_\_\_\_\_

Address: \_\_\_\_\_

City: \_\_\_\_\_

State: \_\_\_\_\_

Zip: \_\_\_\_\_

Phone Number: \_\_\_\_\_

Fax Number: \_\_\_\_\_

Email: \_\_\_\_\_

B. This Plan covers the life of the contract from contract execution through the final contract expiration date.

C. The percentage of total contract dollars, including modifications and renewals, to be paid to all certified minority owned business subcontractors, is \_\_\_\_\_% of the total dollars awarded to Contractor.

D. Each of the following certified minority owned businesses will be paid the percentage of total contract dollars indicated below as a subcontractor under the contract.

I hereby certify that the business(s) listed below are certified by one of the following: Maryland Department of Transportation (MDOT); Virginia Small, Woman and Minority Owned Business (SWAM); Federal SBA (8A); MD/DC Minority Supplier Development Council (MSDC); Women's Business Enterprise National Council (WBENC); or City of Baltimore.

A Certification Letter must be attached.

For assistance, call 240-777-9912.

1. Certified by: \_\_\_\_\_

Subcontractor Name: \_\_\_\_\_

Title: \_\_\_\_\_

Address: \_\_\_\_\_

City: \_\_\_\_\_

State: \_\_\_\_\_

Zip: \_\_\_\_\_

Phone Number: \_\_\_\_\_

Fax Number: \_\_\_\_\_

Email: \_\_\_\_\_

CONTACT PERSON: \_\_\_\_\_

Circle MFD Type:

AFRICAN AMERICAN

ASIAN AMERICAN

DISABLED PERSON

FEMALE

HISPANIC AMERICAN

NATIVE AMERICAN

The percentage of total contract dollars to be paid to this subcontractor: \_\_\_\_\_

This subcontractor will provide the following goods and/or services: \_\_\_\_\_

---

2. Certified by: \_\_\_\_\_

Subcontractor Name: \_\_\_\_\_

Title: \_\_\_\_\_

Address: \_\_\_\_\_

City: \_\_\_\_\_ State: \_\_\_\_\_ Zip: \_\_\_\_\_

Phone Number: \_\_\_\_\_ Fax Number: \_\_\_\_\_ Email: \_\_\_\_\_

CONTACT PERSON: \_\_\_\_\_

Circle MFD Type:

AFRICAN AMERICAN

ASIAN AMERICAN

DISABLED PERSON

FEMALE

HISPANIC AMERICAN

NATIVE AMERICAN

The percentage of total contract dollars to be paid to this subcontractor: \_\_\_\_\_

This subcontractor will provide the following goods and/or services: \_\_\_\_\_

---

3. Certified by: \_\_\_\_\_

Subcontractor Name: \_\_\_\_\_

Title: \_\_\_\_\_

Address: \_\_\_\_\_

City: \_\_\_\_\_ State: \_\_\_\_\_ Zip: \_\_\_\_\_

Phone Number: \_\_\_\_\_ Fax Number: \_\_\_\_\_ Email: \_\_\_\_\_

CONTACT PERSON: \_\_\_\_\_

Circle MFD Type:

AFRICAN AMERICAN

ASIAN AMERICAN

DISABLED PERSON

FEMALE

HISPANIC AMERICAN

NATIVE AMERICAN

The percentage of total contract dollars to be paid to this subcontractor: \_\_\_\_\_

This subcontractor will provide the following goods and/or services: \_\_\_\_\_

---

4. Certified By: \_\_\_\_\_

Subcontractor Name: \_\_\_\_\_

Title: \_\_\_\_\_

Address: \_\_\_\_\_

City: \_\_\_\_\_ State: \_\_\_\_\_ Zip: \_\_\_\_\_

Phone Number: \_\_\_\_\_ Fax Number: \_\_\_\_\_ Email: \_\_\_\_\_



CONTACT PERSON: \_\_\_\_\_

Circle MFD Type:

AFRICAN AMERICAN  
FEMALE

ASIAN AMERICAN  
HISPANIC AMERICAN

DISABLED PERSON  
NATIVE AMERICAN

The percentage of total contract dollars to be paid to this subcontractor: \_\_\_\_\_

This subcontractor will provide the following goods and/or services: \_\_\_\_\_  
\_\_\_\_\_

E. The following language will be inserted in each subcontract with a certified minority owned business listed in D above, regarding the use of binding arbitration with a neutral arbitrator to resolve disputes with the minority owned business subcontractor; the language must describe how the costs of dispute resolution will be apportioned:  
\_\_\_\_\_  
\_\_\_\_\_  
\_\_\_\_\_

F. Provide a statement below, or on a separate sheet, that summarizes maximum good faith efforts achieved, and/or the intent to increase minority participation throughout the life of the contract or the basis for a full waiver request.  
\_\_\_\_\_  
\_\_\_\_\_  
\_\_\_\_\_

G. A full waiver request must be justified and attached.

Full Waiver Approved:

Partial Waiver Approved:

\_\_\_\_\_ Date: \_\_\_\_\_

\_\_\_\_\_ Date: \_\_\_\_\_

MFD Program Officer

MFD Program Officer

Full Waiver Approved:

Partial Waiver Approved:

\_\_\_\_\_ Date: \_\_\_\_\_

\_\_\_\_\_ Date: \_\_\_\_\_

Director  
Cherri Branson  
Office of Procurement

Director  
Cherri Branson  
Office of Procurement

The Contractor submits this MFD Subcontractor Performance Plan (Plan Modification No. \_\_\_\_\_) in accordance with the Minority Owned Business Addendum to General Conditions of Contract between County and Contractor.

CONTRACTOR SIGNATURE

USE ONE:

1. TYPE CONTRACTOR'S NAME: \_\_\_\_\_

\_\_\_\_\_  
Signature

Typed Name

Date

2. TYPE CORPORATE CONTRACTOR'S NAME: \_\_\_\_\_

Signature

Typed Name

Date

I hereby affirm that the above named person is a corporate officer or a designee empowered to sign contractual agreements for the corporation.

Signature

Typed Name

Title

Date

APPROVED:

Cherri Branson, Director, Office of Procurement

Date

Section 7.3.3.4(a) of the Procurement Regulations requires:  
The Contractor must notify the Director, Office of Procurement of any proposed change to the Subcontractor Performance Plan.



Montgomery County  
Division of Business  
Relations & Compliance

MFD Report Of Payments Received

For Office Use Only

MFD Subcontractor Company Name: \_\_\_\_\_

Prime Contractor Company Name: \_\_\_\_\_

Contract Number/Title: \_\_\_\_\_

Project Location: \_\_\_\_\_

MFD Subcontract Amount: \$ \_\_\_\_\_

READ CAREFULLY BEFORE SIGNING

This certifies that for the month of \_\_\_\_\_, my company received \$ \_\_\_\_\_ for work performed, services rendered and/or materials supplied on the above contract.

TOTAL AMOUNT OF SUBMITTED INVOICES TO DATE: \$ \_\_\_\_\_

TOTAL PAYMENTS RECEIVED TO DATE: \$ \_\_\_\_\_

Are you experiencing any contract problems with the prime contractor and/or the project? YES  NO

I certify that the above information is true and accurate to the best of my record documentation and knowledge.

\_\_\_\_\_  
(TYPED/PRINTED COMPANY NAME)

\_\_\_\_\_  
(TYPED/PRINTED NAME OF COMPANY OFFICIAL) (TITLE)

\_\_\_\_\_  
SIGNATURE OF COMPANY OFFICIAL) (DATE)

( ) - ( ) - \_\_\_\_\_  
TELEPHONE FAX E-MAIL

Return by: Email – [MFD@montgomerycountymd.gov](mailto:MFD@montgomerycountymd.gov) FAX – 240-777-9952  
For assistance, contact the MFD Office at 240-777-9912



Montgomery County  
Division of Business  
Relations & Compliance

MFD Report Of Payments Received

For Office Use Only

SAMPLE ONLY! NOT TO BE USED BY PRIME

MFD Subcontractor Company Name: \_\_\_\_\_

Prime Contractor Company Name: \_\_\_\_\_

Contract Number/Title: \_\_\_\_\_

Project Location: \_\_\_\_\_

MFD Subcontract Amount: \$ \_\_\_\_\_

READ CAREFULLY BEFORE SIGNING

This certifies that for the month of \_\_\_\_\_, my company received \$ \_\_\_\_\_ for work performed, services rendered and/or materials supplied on the above contract.

TOTAL AMOUNT OF SUBMITTED INVOICES TO DATE: \$ \_\_\_\_\_

TOTAL PAYMENTS RECEIVED TO DATE: \$ \_\_\_\_\_

Are you experiencing any contract problems with the prime contractor and/or the project? YES  NO

Comments: \_\_\_\_\_

I certify that the above information is true and accurate to the best of my record documentation and knowledge.

\_\_\_\_\_  
(TYPED/PRINTED COMPANY NAME)

\_\_\_\_\_  
(TYPED/PRINTED NAME OF COMPANY OFFICIAL) (TITLE)

\_\_\_\_\_  
SIGNATURE OF COMPANY OFFICIAL) (DATE)

( ) - ( ) - \_\_\_\_\_  
TELEPHONE FAX E-MAIL

Return by: Email – [MFD@montgomerycountymd.gov](mailto:MFD@montgomerycountymd.gov) FAX – 240-777-9952  
For assistance, contact the MFD Office at 240-777-9912

IFB #1109382  
SPECIFICATIONS FOR ELEVATOR RENOVATION  
STRATHMORE MANSION

THE AMERICAN INSTITUTE OF ARCHITECTS



AIA Document A310

**Bid Bond**

KNOW ALL MEN BY THESE PRESENTS, that we \_\_\_\_\_  
(Here insert full name and address or legal title of Contractor)

as Principal, hereinafter called the Principal, and \_\_\_\_\_  
(Here insert full name and address or legal title of Surety)

a corporation duly organized under the laws of the State of \_\_\_\_\_  
as Surety, hereinafter called the Surety, are held and firmly bound unto \_\_\_\_\_  
(Here insert full name and address or legal title of Owner)

as Obligee, hereinafter called the Obligee, the sum of \_\_\_\_\_  
Dollars (\$ \_\_\_\_\_),

for the payment of which sum well and truly to be made, the said Principal and the said Surety, bind ourselves, our heirs, executors, administrators, successors and assigns, jointly and severally, firmly by these presents.

WHEREAS, the Principal has submitted a bid for \_\_\_\_\_  
(Here insert full name, address and description of project)

NOW, THEREFORE, if the Obligee shall accept the bid of the Principal, the Principal shall enter into a Contract with the Obligee in accordance with the terms of such bid, and give such bond or bonds as may be specified in the bidding or Contract Documents with good and sufficient surety for the faithful performance of such Contract and for the prompt payment of labor and material furnished in the prosecution thereof, or in the event of the failure of the Principal to enter such Contract and give such bond or bonds, if the Principal shall pay to the Obligee the difference not to exceed the penalty hereof between the amount specified in said bid and such larger amount for which the Obligee may in good faith contract with another party to perform the Work covered by said bid, then this obligation shall be null and void, otherwise to remain in full force and effect.

Signed and sealed this \_\_\_\_\_ day of \_\_\_\_\_ 19\_\_\_\_

\_\_\_\_\_  
(Witness) { \_\_\_\_\_  
(Principal) (Seal)  
\_\_\_\_\_  
(Title)

\_\_\_\_\_  
(Witness) { \_\_\_\_\_  
(Surety) (Seal)  
\_\_\_\_\_  
(Title)

**SPECIFICATIONS FOR ELEVATOR RENOVATION  
STRATHMORE MANSION**

MONTGOMERY COUNTY, MARYLAND

MONTGOMERY COUNTY, MARYLAND

**FIXED PRICE CONSTRUCTION  
CONTRACT BETWEEN  
OWNER AND CONTRACTOR**

This FIXED PRICE CONSTRUCTION CONTRACT (the "Contract") BETWEEN OWNER AND CONTRACTOR (Owner and Contractor together the "Parties") is made and entered into by and between MONTGOMERY COUNTY, MARYLAND a body corporate and politic and a political subdivision of the State of Maryland (the "Owner") and (the "Contractor").

This Contract is effective on the date executed by the Director, Department of General Services.

**This Contract is for the construction of a project identified as the elevator renovation for Strathmore Mansion, Montgomery County, Maryland (the "Project").**

NOW, THEREFORE, in consideration of the mutual promises, covenants and agreements stated herein, and for other good and valuable consideration, the sufficiency of which is hereby acknowledged, the Parties agree:

1.

**DOCUMENTS INCORPORATED BY REFERENCE**

(A) This Contract consists of this Contract and any documents referenced in this Contract or in any of the following exhibits:

- (1) IFB No.
- (2) Drawings and Specifications for the Project identified on Attachment A;
- (3) General Conditions of Construction Contract, VGCofC 11072018;
- (4) Supplemental Conditions of Construction Contract, if any; **(Page 66)**
- (5) Mandatory Insurance Requirements; **(Page 64)**
- (6) Performance and Payment Bonds; **(Page 53-59)**
- (7) addenda to any of the foregoing;
- (8) modifications issued hereafter to any of the foregoing;
- (9) Contractor's Acknowledgment of Addendum #X;

IFB #1109382  
**SPECIFICATIONS FOR ELEVATOR RENOVATION**  
**STRATHMORE MANSION**

- (10) Notice to Proceed;
- (11) Master Schedule and Critical Contract Completion Periods (*Section 00 8000*);
- (12) all applicable provisions of the Montgomery County Code and Procurement Regulations in effect on the Bid or Proposal closing date and any procedural amendments or additions subsequently adopted are part of the Contract all of which are incorporated by reference and made a part of this Contract.

(B) All of these documents referenced in this Article 1 together are collectively referred to as the "Contract" or "Contract Documents". Documents not included or expressly referenced in this Article 1 do not form any part of this Contract. Capitalized terms used in this Contract have the meaning ascribed to them in the General Conditions of Construction Contract. The General Conditions of Construction Contract are supplemental and additional to the terms and conditions of this Contract and must be complied with by the Contractor as fully as if set forth verbatim in this Contract. In the event of any conflict between the terms of this Contract and the General Conditions of Construction Contract, the most stringent will govern.

2.

**REPRESENTATIONS AND WARRANTIES OF THE CONTRACTOR**

The Contractor makes the following representations and warranties in order to induce the Owner to execute this Contract. The Contractor recognizes that, in making these representations and warranties, Owner is entitled to rely upon the Contractor's representations and warranties and is relying upon them in entering this Contract. The Contractor, by executing this Contract, makes the following express representations and warranties to the Owner:

(A) The Contractor is fully qualified to act as the Contractor and perform the Work for the Project and has, and shall maintain, all licenses, permits or other authorizations necessary to act as the Contractor for, and to construct, the Work for the Project.

(B) The Contractor has become familiar with the Project Site and the local conditions under which the Project is to be constructed and operated.

(C) Contractor is responsible for performing Work shown on the Contract Documents, including reasonably implied or inferred Work from the Contract Documents, which a reasonably prudent contractor of Contractor's reputation, expertise and experience would conclude were inferable from the Contract Documents.



IFB #1109382  
**SPECIFICATIONS FOR ELEVATOR RENOVATION**  
**STRATHMORE MANSION**

3.

**INTENT AND INTERPRETATION**

With respect to the intent and interpretation of this Contract, the Owner and the Contractor agree as follows:

(A) This Contract (which includes all Contract Documents) constitutes the entire and exclusive agreement between the parties with reference to the Work and the Project. This Contract supersedes any and all prior discussions, communications, representations, understandings, negotiations, or agreements.

(B) Anything that may be required, implied, or inferred by the documents that make up this Contract, or any one or more of them, must be provided by the Contractor for the Contract Sum within the Contract Time.

(C) Nothing contained in this Contract creates, nor is to be interpreted to create, privity or any other relationship whatsoever between the Owner and any person or entity except the Contractor or between the Contractor and any other person or entity except the Owner.

(D) When a word, term, or phrase is used in this Contract, it is to be interpreted or construed first, as defined in the General Conditions of Construction Contract including any supplemental terms and conditions of the Contract, if any; second, as defined in this Contract; third, if not defined, according to Referenced Standards and its generally accepted meaning in the construction industry; and fourth, if there are no Referenced Standards or generally accepted meaning in the construction industry, according to its common and customary usage.

(E) The words "include", "includes", or "including", as used in this Contract, are deemed to be followed by the phrase, "without limitation".

(F) The specification in this Contract of any act, failure, refusal, omission, event, occurrence, or condition as constituting a material breach of this Contract does not imply that any other, non-specified act, failure, refusal, omission, event, occurrence, or condition is to be deemed not to constitute a material breach of this Contract.

(G) The Contractor has a continuing duty to read, examine, review, compare, and contrast each of the Contract Documents that make up this Contract, and must give written notice to the Owner and the Architect of any conflict, ambiguity, error, or omission which the Contractor may find with respect to the Contract Documents that come to the attention of Contractor during the course of the Work and before proceeding with any part of the Work affected by the conflict,



IFB #1109382  
**SPECIFICATIONS FOR ELEVATOR RENOVATION**  
**STRATHMORE MANSION**

ambiguity, error, or omission. The express or implied approval by the Owner or the Architect of any Shop Drawings or other Submittals does not relieve the Contractor of the continuing duties imposed by this Contract, nor is any such approval evidence of the Contractor's compliance with this Contract. The Owner has requested the Architect only to prepare documents for the Project, including the Drawings and Specifications for the Project, which are accurate, adequate, consistent, coordinated, and sufficient for construction.

(H) In the event of any conflict, discrepancy, or inconsistency among any of the Contract Documents, the following shall control:

- (1) As between figures given on Drawings and scaled measurements, the figures govern;
- (2) As between large scale Drawings and small-scale Drawings, the most stringent will govern;
- (3) As between Drawings and Specifications, the most stringent will govern; and
- (4) As between the General Conditions of Construction Contract or this Contract and the Drawings or Specifications, the General Conditions of Construction Contract and this Contract govern.

4.

#### OWNERSHIP OF THE DOCUMENTS WHICH MAKE UP THE CONTRACT

The Contract Documents, and each of them, as well as any other documents furnished by the Owner, remain the property of the Owner. The Contractor must not use, or permit to be used, any portion or all of the Contract Documents or other documents furnished by the Owner on other projects without the Owner's prior written authorization.

5.

#### CONTRACTOR'S PERFORMANCE

The Contractor must perform all of the Work required, implied or reasonably inferable from the Contract Documents including, but not limited to, the following:

- (A) Construction of the Work (including all warranty work) for the Project.

**SPECIFICATIONS FOR ELEVATOR RENOVATION  
STRATHMORE MANSION**

(B) The furnishing and maintenance of all required surety bonds, insurance, Warranties, and related documentation.

(C) The provision or furnishing, and prompt payment, of labor, supervision, services, materials, supplies, equipment, fixtures, appliances, facilities, tools, transportation, storage, power, fuel, heat, light, cooling, or other utilities, required for construction of the Work for the Project, and all necessary permits and licenses required for the construction of the Work for the Project, as provided in the General Conditions of Construction Contract.

(D) Full, prompt, and complete compliance with all of the Contract Documents, without limitation, including the General Conditions of Construction Contract.

6.

**TIME FOR CONTRACTOR'S PERFORMANCE**

**(A) The Contractor must commence the performance of this Contract upon Notice to Proceed as set forth in the General Conditions of Construction Contract and must diligently perform under the Contract and complete the Work without interruption through final completion of the Work for the Project. The contract is divided in 2 phases. Phase #1 is 60 calendar days duration. Phase #2 is 140 calendar days duration. The Contractor must achieve Substantial Completion of the Work for the Project within 200 calendar days of Notice to Proceed for Phase #1.**

(B) The Contractor must promptly notify the Owner and Architect in writing when Substantial Completion has been achieved. The Contractor must comply with the provisions of Section 14.2 of the General Conditions of Construction Contract.

(C) The Contractor must notify the Owner and Architect in writing when Final Completion has been achieved and the Contractor is ready for a final inspection. The Contractor must comply with the provisions of Sections 14.3 and 14.4 of the General Conditions of Construction Contract.

**(D) The Contractor must pay the Owner the sum of Five Hundred Dollars (\$500.00) as Liquidated Damages for each day of unexcused delay beyond the date set forth above for Substantial Completion** When the Owner reasonably believes that Substantial Completion will be inexcusably delayed, the Owner is entitled, but not required, to withhold from any amounts otherwise due the Contractor an amount then believed by the Owner to be adequate to recover Liquidated Damages applicable to the Delays. If and when the Contractor overcomes any unexcused Delay in achieving Substantial Completion, or any

IFB #1109382  
**SPECIFICATIONS FOR ELEVATOR RENOVATION**  
**STRATHMORE MANSION**

Delay, for which the Owner has withheld payment, the Owner will promptly release to the Contractor those funds withheld, but no longer applicable, as Liquidated Damages.

(E) The Contractor's payment of any Liquidated Damages to the Owner is in addition to and not exclusive of any other remedies available to the Owner under the terms of this Contract or the Contract Documents.

(F) All limitations of time applicable to the Contractor set forth in this Contract and the Contract Documents are material and are of the essence of this Contract.

7.

**FIXED SUM AND CONTRACT PAYMENTS**

(A) The Owner will pay, and the Contractor accepts, as full and complete payment for the Contractor's timely performance of its obligations under this Contract (including performance of and compliance with all of the General Conditions of Construction Contract and other Contract Documents) the fixed sum of \_\_\_\_\_ Dollars (\$\_\_\_\_\_). The sum set forth in this Article 7(A) constitutes the Contract Sum, which cannot be modified except as provided in the General Conditions of Construction Contract or by written Amendment executed by the parties to this Contract.

(B) The Contractor is bound by the Owner-approved Schedule of Values apportioning the Contract Sum among the different elements of the Work for the Project for purposes of periodic and final payment as provided in the General Conditions of Construction Contract. The Contractor's Schedule of Values must not be inflated, unbalanced or misstated in any way to give the Contractor an unfair advantage during the Bid or Proposal or construction processes. The violation of this provision by the Contractor constitutes a material breach of this Contract. The Contractor's Schedule of Values as approved by the Owner and Architect/Engineer as provided in the General Conditions of Construction Contract will be utilized for the Contractor's Applications for Payment.

(C) The Owner will pay the Contract Sum to the Contractor, less amounts established for retainage, in accordance with Article 13 of the General Conditions of Construction Contract. All Applications for Payment must be in the format, and include all supporting information, required by the Contract Documents as well as any other information required by the Owner, the Architect, or both. The Owner and Architect will approve in writing the amount that is properly owing to the Contractor and certify the amount of payment then due to the Contractor as provided in the General Conditions of Construction Contract. The Owner will make payment to the Contractor as required by the General Conditions of Construction Contract. The amount of each such payment will be made in the

**SPECIFICATIONS FOR ELEVATOR RENOVATION  
STRATHMORE MANSION**

amount approved for payment in accord with the General Conditions of Construction Contract less any amounts that the Contractor owes the Owner or which the Owner has the right to withhold under the Contract Documents. The Architect's approval of the Contractor's Applications for Payment does not preclude the Owner from exercising any of its rights in Article 7(F), below or elsewhere in the Contract Documents. As a condition precedent to payment, the Contractor must, if required by the Owner, furnish to the Owner properly executed waivers of lien, in a form acceptable to the Owner, from all Subcontractors, materialmen, laborers, Suppliers, or others having lien rights, in which the Subcontractors, materialmen, laborers, Suppliers, or others having lien rights, acknowledge receipt of all sums due pursuant to all prior Applications for Payment and waive and relinquish any liens, lien rights, or other claims relating to the Project Site or the Work. Furthermore, the Contractor warrants and represents that, upon payment of the Application for Payment submitted, title to all Work included in the payment is vested in the Owner. The Owner's right to require lien waivers as a precondition to payment is solely for the benefit of the Owner and shall not be construed to give any third party, including specifically any Subcontractors, materialmen laborers, Suppliers, or others having lien rights, or surety on any payment or performance bonds any rights nor make the Owner liable to any of them as a consequence of the Owner's decision or failure to request or obtain such lien waivers as a precondition to payment.

(D) When payment is received from the Owner, the Contractor must immediately pay all Subcontractors, materialmen, laborers, and Suppliers the amounts they are due for the Work covered by such payment, as provided in the General Conditions of Construction Contract. The Owner will have the right, but not the duty, to issue future checks and payment to the Contractor of amounts otherwise due under the Contract naming the Contractor and any such Subcontractor, materialmen, laborer, or Supplier as joint payees. Such joint check procedure, if employed by the Owner, does not create any rights in favor of any person or entity beyond the right of the named payees to payment of the check and does not require the Owner to repeat the procedure in the future.

(E) Neither payment to the Contractor, utilization of the Work or the Project for any purpose by the Owner, nor any other act or omission by the Owner is to be interpreted or construed as an acceptance of any Work of the Contractor that is not strictly in compliance with construction industry standards and the requirements of this Contract.

(F) The Owner has the right to refuse to make payment and, if necessary, may demand the return of a portion or the entire amount previously paid to the Contractor due to any reason stated in Article 13 of the General Conditions of Construction Contract. The Contractor must immediately comply with any written demand by the Owner for repayment or reimbursement of the Owner for any amounts previously paid by the Owner as contemplated in this Article.

**SPECIFICATIONS FOR ELEVATOR RENOVATION  
STRATHMORE MANSION**

(G) The Contractor has no right to stop Work as a consequence of non-payment. In the event of any dispute between the Contractor and Owner involving the Contractor's claim to entitlement to payment the Contractor's only remedy is to file a claim with the Contract Administrator as provided in the General Conditions of Construction Contract. The Contractor must diligently proceed with the Work pending resolution of the claim or dispute. Any payments on Certificates for Payment which are approved by the Owner as "proper invoices" within the meaning of applicable laws and regulations not made within thirty (30) days after the Owner approves the Certificate for Payment shall bear interest at a rate equivalent to the interest rate paid by 5 year U.S. Treasury Bills as of the date interest first begins to accrue under Section 11B-34 of the Montgomery County Code, 2004, as amended. An Owner approved Certificate for Payment is one that has been certified as required by the Architect, accepted by the Contract Administrator or designee, and fully complies with the requirements of Article 13 of the General Conditions of Construction Contract.

(H) Prior to being entitled to receive final payment, and as a condition precedent to final payment, the Contractor must furnish the Owner all items required in Section 14.3 of the General Conditions of Construction Contract in the form and manner required by Owner, with a copy to the Architect.

8.

**INFORMATION AND MATERIAL SUPPLIED BY THE OWNER**

(A) The Owner will, if requested by the Contractor, furnish to the Contractor, prior to the execution of this Contract, any and all written and tangible material in its possession concerning conditions below ground at the Site of the Project. The Owner shall also furnish, if appropriate, the legal description of the Project Site, and any required survey in the Owner's possession or under the Owner's control.

(B) Geotechnical Studies: Geotechnical Studies refers to those reports of explorations and tests of subsurface conditions at or contiguous to the Site, which have been prepared for the use of the Architect/Engineer and/or Owner in designing the project. Their accuracy or completeness is limited to the very narrow parameters of locations, timing and depth of the borings, pits and other analyses. As such, they are not intended to, and do not, provide a comprehensive representation of subsurface conditions. The Geotechnical Studies have been made part of the Contract Documents for the limited purpose of design of the Work. The Geotechnical Studies shall not be relied upon by the Contractor for any means or methods of construction. Contractors and Offerors may make their own investigation of existing subsurface conditions. For Contract Modification purposes, the Geotechnical Studies establish a baseline for expected subsurface conditions. The Contractor must show a material difference



IFB #1109382  
**SPECIFICATIONS FOR ELEVATOR RENOVATION**  
**STRATHMORE MANSION**

between the Geotechnical Studies and actual subsurface conditions to justify a Contract Modification.

9.

**DUTIES, OBLIGATIONS AND RESPONSIBILITIES OF THE CONTRACTOR**

In addition to any and all other duties, obligations, and responsibilities of the Contractor set forth in this Contract and the General Conditions of Construction Contract, the Contractor has and must perform the following duties, obligations, and responsibilities:

(A) The Contractor must continually perform its duties set forth in Article 3(G). The Contractor must not perform Work without adequate Drawings and Specifications, or, as appropriate, approved Shop Drawings, or other Submittals. If the Contractor performs Work knowing or believing it involves an error, inconsistency, or omission in the Contract, without first providing written notice to the Architect and Owner, the Contractor is responsible for the Work and must pay all costs of correcting it.

(B) All Work must conform strictly to the requirements of the Contract.

(C) The Contractor must strictly supervise the performance and completion of the Work, and must monitor the Work as it progresses. The Contractor is strictly liable for all acts and omissions of those engaged in the Work on behalf of the Contractor.

(D) The Contractor warrants that all labor furnished under this Contract will be competent to perform the tasks undertaken; that the product of such labor will yield only first-class results; that all materials used in the Work and equipment provided will be new and of high quality; that the Work will be complete, of high quality, without defects, when completed; and that all of the Work will strictly comply with the requirements of the Contract. Any Work not strictly complying with the requirements of the Contract will be a breach of the Contractor's warranty.

(E) The Contractor must obtain and pay for all required permits, fees, and licenses as set forth in Article 5.2.3 of the General Conditions of Construction Contract, in any Supplemental Conditions of Construction Contract and in any other Contract Documents. The Contractor must comply with all Laws and Regulations applicable to the Project and to the Work.

(F) The Contractor must employ and maintain at the Project Site only competent supervisory personnel. Key personnel must be assigned by the Contractor to this Project and may be changed only as provided in the General Conditions of Construction Contract.

**SPECIFICATIONS FOR ELEVATOR RENOVATION  
STRATHMORE MANSION**

(G) The Contractor must provide the Owner and the Architect its Construction Project Progress Schedule in accordance with the General Conditions of Construction Contract. The Progress Schedule must conform to the General Conditions of Construction Contract, be in the format specified in the Contract Documents, and otherwise be acceptable to the Owner. The Contractor's Progress Schedule must be updated no less frequently than monthly and must be updated to reflect the current progress of the Work, any conditions that change the critical path or the dates for Substantial or Final Completion of the Work, and any additions or changes to the Work. Each such revision is to be furnished to the Owner and the Architect. Strict compliance with the requirements of this Article 9(G) is a condition precedent to payment to the Contractor, and failure by the Contractor to strictly comply with these requirements constitutes a material breach of this Contract.

(H) The Contractor must keep an updated copy of the Contract, the General Conditions of Construction Contract, any Supplemental Conditions of Construction Contract, and an updated posted set of the plans and specifications reflecting any and all changes at the Project Site. Additionally, the Contractor must keep a copy of, and a log of, approved Shop Drawings and other Submittals and copies of, and a log of, all Requests for Information (RFIs) and Supplemental Instructions (SIs) issued with respect to the Work or the Project at the Site at all times. All of these items shall be available to the Owner and the Architect during all regular business hours. Upon Final Completion of the Work, all of these items must be finally updated and provided to the Owner and will be the property of the Owner.

(I) Shop Drawings and other Submittals from the Contractor are not Contract Documents and are not part of the Contract. See Section 9.1.5 of the General Conditions of Construction Contract. The Contractor must not do any Work requiring Shop Drawings or other Submittals unless the Shop Drawings and Submittals have been approved in writing by the Architect. All Work requiring approved Shop Drawings or other Submittals must be done in strict compliance with the Contract Documents. However, approval by the Architect or the Owner is not evidence that Work installed pursuant to the Shop Drawings or Submittals conforms to the requirements of this Contract. The Owner and the Architect have no duty to review partial Submittals or incomplete Submittals. The Contractor must maintain a Submittal log which must include, at a minimum, the date of each Submittal, the date of any resubmittal, the date of any approval or rejection, and the reason for any approval or rejection. The Contractor has the duty to carefully review, inspect, and examine any and all Submittals before submitting them to the Owner or the Architect.

(J) The Contractor must maintain the Project Site in a reasonably clean condition during performance of the Work. Upon Final Completion, the Contractor

IFB #1109382  
**SPECIFICATIONS FOR ELEVATOR RENOVATION**  
**STRATHMORE MANSION**

must thoroughly clean the Project Site of all debris, trash and excess materials or equipment as provided in the General Conditions of Construction Contract.

(K) At all times relevant to this Contract, the Contractor must permit the Owner and the Architect to enter upon the Project Site and to review or inspect the Work without formality or other procedure.

10.

**CONTRACT ADMINISTRATOR AND PROJECT ARCHITECT**

The Contract Administrator for this Project is:  
Gregory Boykin, Division Chief  
Montgomery County Department of General Services  
Division of Facility Management  
1301 Seven Locks Road  
Rockville, MD 20854  
Phone: (240) 777-6097

**The "Architect", "Architect/Engineer" or "A/E" for this Project is:**  
**Robert L. Seymour Associates, Inc.**  
**Attn: Robert S. Seymour**  
**182 Thomas Johnson Drive, Suite 200**  
**Frederick, MD 21702**  
**Phone: (301) 662-8112**  
**Fax: (301) 662-8117**  
**E-mail: rlsainc2@aol.com**

Unless otherwise directed by the Owner in writing, the Architect will perform those duties and discharge those responsibilities allocated to the Architect in the General Conditions of Construction Contract.

THE DUTIES, OBLIGATIONS AND RESPONSIBILITIES OF THE CONTRACTOR UNDER THIS CONTRACT SHALL IN NO MANNER WHATSOEVER BE CHANGED, ALTERED, DISCHARGED, RELEASED, OR SATISFIED BY ANY DUTY, OBLIGATION OR RESPONSIBILITY OF THE ARCHITECT. THE CONTRACTOR IS NOT A THIRD-PARTY BENEFICIARY OF ANY CONTRACT BY AND BETWEEN THE OWNER AND THE ARCHITECT. IT IS EXPRESSLY ACKNOWLEDGED AND AGREED THAT THE DUTIES OF THE CONTRACTOR TO THE OWNER ARE INDEPENDENT OF, AND ARE NOT DIMINISHED BY, ANY DUTIES OF THE ARCHITECT TO THE OWNER.

11.

**CLAIMS BY THE CONTRACTOR**



IFB #1109382  
**SPECIFICATIONS FOR ELEVATOR RENOVATION**  
**STRATHMORE MANSION**

Claims by the Contractor against the Owner are subject to the following terms and conditions:

(A) All Contractor claims against the Owner must be initiated by a written claim submitted to the Owner and the Architect in strict accordance with Articles 11, 12 and/or 16 of the General Conditions of Construction Contract, and the requirements of Chapter 11B of the Montgomery County Code, 2004, as amended, and the Montgomery County Procurement Regulations, Chapter 11B of the Code of Montgomery County Regulations (COMCOR), as amended. Any claim must be received by the Owner and the Architect no later than ten (10) days after the event giving rise to the claim. **ANY CLAIM NOT FILED WITH THE OWNER AND ARCHITECT WITHIN SUCH TIME AND IN COMPLIANCE WITH THE PRECEDING PROVISIONS SHALL BE DEEMED CONCLUSIVELY TO HAVE BEEN WAIVED AND SHALL BE DISMISSED.**

(B) The Contractor must continue its performance under this Contract regardless of the existence of any claims submitted by the Contractor.

(C) In connection with any claim by the Contractor against the Owner for compensation in excess of the Contract Sum, any liability of the Owner to the Contractor shall be strictly limited and computed in accord with Articles 11 and 12 of the General Conditions of Construction Contract and shall in no event include indirect costs (such as home office overhead) or consequential damages of the Contractor or any estimated costs or damages. **The Owner is not liable to the Contractor for claims of third parties, including Subcontractors or Suppliers. The Contractor may not add or join the Owner as a Party (third-party defendant or otherwise) in any litigation or arbitration between Contractor and any third parties, including Subcontractors or Suppliers.** In addition, the Owner's liability for any contract claims is limited in the case of a Change Order to amounts computed in accordance with Section 12.2.2 of the General Conditions of Construction Contract, and in the case of any compensable delay claim to amounts computed in accordance with Section 11.6.9 of the General Conditions of Construction Contract.

(D) In the event the Contractor is delayed in performing any task, which at the time of the Delay is then critical, as provided in the General Conditions of Construction Contract, or which during the delay becomes critical, as the sole and exclusive result of any act or omission by the Owner, or someone acting on the Owner's behalf, or by Owner-authorized Change Orders, unusually severe weather not reasonably anticipatable, fire, or other Acts of God, occurring without the fault or negligence of the Contractor, the date for achieving Substantial Completion, or, as applicable, Final Completion, will be appropriately adjusted by the Owner upon the written claim of the Contractor to the Owner and the Architect filed in full compliance with Article 11 of the General Conditions of

**SPECIFICATIONS FOR ELEVATOR RENOVATION  
STRATHMORE MANSION**

Construction Contract. A task is critical within the meaning of this Article 11(D) if, the task is on the critical path of the most recent CPM Schedule of Record so that a Delay in performing the task will Delay the ultimate completion of the Project. ANY CLAIM FOR AN EXTENSION OF TIME BY THE CONTRACTOR MUST STRICTLY COMPLY WITH THE REQUIREMENTS OF ARTICLE 11(A) ABOVE. IF THE CONTRACTOR FAILS TO MAKE SUCH CLAIM AS REQUIRED IN THIS ARTICLE 11(D), ANY CLAIM FOR AN EXTENSION OF TIME WILL BE WAIVED AND SHALL BE DISMISSED.

12.

**SUBCONTRACTORS**

Within the time and conditions provided in Article 6 of the General Conditions of Construction Contract, the Contractor shall identify to the Owner and the Architect, in writing, those persons or entities that will be the Subcontractors on the Project. The Owner will state in writing any objections the Owner may have to any such Subcontractors as provided in the General Conditions of Construction Contract. The Contractor must not enter into a subcontract with a Subcontractor to whom the Owner objects. All subcontracts shall afford the Contractor rights against the Subcontractor that correspond to those rights afforded to the Owner against the Contractor as provided in the General Conditions of Construction Contract, including those rights of Contract termination as set forth in the General Conditions of Construction Contract. Any replacement Subcontractors must be acceptable to the Owner.

13.

**CHANGE ORDERS**

The Owner may order one or more changes to the Work within the general scope of this Contract. The Contractor must proceed with any such changes, and any Contractor claim regarding any such change must be made in strict accordance with Articles 11, 12 and 16 of the General Conditions of Construction Contract and Article 11 of this Contract.

(A) The Contractor must notify and obtain the consent and approval of the Contractor's Surety with reference to all Change Orders if such notice, consent or approval is required by the Owner, the Architect, the Contractor's Surety or by law. The Contractor's performance of Change Order Work constitutes the Contractor's warranty to the Owner that the surety has been notified of, and consents to, such Change Order Work AND THE SURETY SHALL BE CONCLUSIVELY DEEMED TO HAVE BEEN NOTIFIED OF SUCH CHANGE ORDER WORK AND TO HAVE EXPRESSLY CONSENTED TO THE CHANGE ORDER WORK.

**SPECIFICATIONS FOR ELEVATOR RENOVATION  
STRATHMORE MANSION**

(B) ANY CLAIM ABOUT AN ADJUSTMENT IN THE CONTRACT TIME OR CONTRACT SUM DUE TO A CHANGE MUST BE GIVEN IN WRITING TO THE OWNER AND ARCHITECT AS PROVIDED IN ARTICLES 11, 12 AND 16 OF THE GENERAL CONDITIONS OF CONSTRUCTION CONTRACT AND ARTICLE 11 OF THIS CONTRACT, OR THE CLAIM IS WAIVED. Any failure to agree upon an adjustment in the Contract Time or Contract Sum must be resolved under Article 16 of the General Conditions of Construction Contract. The Contractor must proceed with the prosecution of the Work as changed, even if there is an unresolved claim. No charge for any extra work, time or material will be allowed, except as provided in this Article.

14.

**DISCOVERING AND CORRECTING DEFECTIVE OR INCOMPLETE WORK**

Inspection and correction of the Work and Contractor's warranties shall be as provided in Article 10 of the General Conditions of Construction Contract.

15.

**NO TERMINATION BY THE CONTRACTOR**

The Contractor does not have a right to terminate the Contract. As provided in Article 15 of the General Conditions of Construction Contract, the Contractor has no right to stop Work on the Project. In the event of any dispute between Contractor and Owner involving the Contractor's claim to entitlement to any payment, the Contractor, as required by the General Conditions of Construction Contract, must diligently proceed with the Work pending resolution of the dispute.

16.

**OWNER'S RIGHT TO SUSPEND CONTRACTOR'S PERFORMANCE**

The Owner has the right to suspend or stop Work as provided in Articles 11 and 15 of the General Conditions of Construction Contract.

17.

**TERMINATION BY THE OWNER**

The Owner may terminate this Contract in accordance with Article 15 of the General Conditions of Construction Contract.

18.

IFB #1109382  
**SPECIFICATIONS FOR ELEVATOR RENOVATION**  
**STRATHMORE MANSION**

**INSURANCE**

The Contractor must comply with the insurance requirements set forth in the Bid or Proposal Documents and Article 17 of the General Conditions of Construction Contract.

**19.**

**SURETY BONDS**

The Contractor must furnish separate Bid, performance and payment bonds to the Owner in the forms prescribed in the Bid or Proposal Documents and Article 17 of the General Conditions of Construction Contract. The performance and payment bonds must set forth a penal sum in an amount not less than 95% of the Contract Sum. Each bond furnished by the Contractor must incorporate by reference the terms of this Contract as fully as though they were set forth verbatim in the bonds. The penal sum of both the performance and payment bonds will be automatically increased in the amount of any increase to the Contract Sum. The performance and payment bonds furnished by the Contractor must be in the forms prescribed in the Bid or Proposal Documents and Article 17 of the General Conditions of Construction Contract. The Surety must be a corporate Surety authorized to do business in the State of Maryland and acceptable to the Owner. While determining Surety acceptability, the Owner may make such investigations as he deems necessary to determine the ability of the Contractor's Surety to perform its duties and obligations and the Contractor shall furnish to the Owner, within five (5) days of Owner request, all such data and information for this purpose as the Owner may request. The Owner reserves the right, in its absolute discretion and for any reason, to accept or reject any Surety proposed by the Contractor.

**20.**

**PROJECT RECORDS**

The Contractor must make available to the Owner and the Architect all or any part of any documents relating in any manner to the Project that are in the possession of the Contractor or any Subcontractor of the Contractor (the "Project Records") for inspection and copying at any reasonable time upon request by the Owner or the Architect. The Contractor must make the Contract Documents, Record Documents, and any Project Records available for inspection and copying by any state, federal, or other regulatory authority at any time upon the request of either the Owner or the state, federal, or other regulatory authority requesting the right to inspect or copy the Contract Documents, Record Documents, or Project Records. The Project Records include, but are not limited to, all written records concerning the Project, all drawings, printouts, disks, plans, specifications, submittals, correspondence, minutes, memoranda, tape

IFB #1109382  
**SPECIFICATIONS FOR ELEVATOR RENOVATION  
STRATHMORE MANSION**

recordings, videos, or other writings or things that document the Project, its design, and its construction, including the Record Documents, as defined in the General Conditions of Construction Contract. The Project Records expressly include those documents reflecting the cost of construction to the Contractor, including the Contractor's Bid sheet(s) and/or Bid calculation takeoffs and estimates. The Contractor shall maintain and protect these documents for no less than four (4) years after Final Completion of the Project, or for any longer period of time as may be required by law or good construction practice.

**21.**

**APPLICABLE LAW**

This Contract must be construed under the law of the State of Maryland, without regard to conflicts of law provisions.

**22.**

**SUCCESSORS AND ASSIGNS**

This Contract is binding on the Parties and their respective successors, heirs, and assigns. The Contract must not be assigned without prior written consent of the Owner and except as otherwise provided in this Contract.

**23.**

**BACKGROUND INVESTIGATIONS**

The County may, at its sole discretion, require a background investigation for any of the Contractor's employees or Subcontractors' employees performing work under a County construction contract. Such background investigations will be performed by the County at the County's expense and may include, without limitation, a criminal background investigation. The Contractor must timely cooperate with the County in any background investigations, including providing without unreasonable delay any information necessary to complete the investigation.

IFB #1109382  
**SPECIFICATIONS FOR ELEVATOR RENOVATION**  
**STRATHMORE MANSION**

**SIGNATURE PAGE FOLLOWS**

IFB #1109382  
**SPECIFICATIONS FOR ELEVATOR RENOVATION**  
**STRATHMORE MANSION**

**Owner:**  
MONTGOMERY COUNTY,  
MARYLAND

**Contractor:**

\_\_\_\_\_  
(Company Name)

\_\_\_\_\_  
(Signature)  
Avinash G. Shetty, Director  
Office of Procurement

\_\_\_\_\_  
(Signature)

\_\_\_\_\_  
(Printed Name)

\_\_\_\_\_  
(Title)

\_\_\_\_\_  
(Date)

\_\_\_\_\_  
(Date)

**Recommended by:**

\_\_\_\_\_  
(Signature)  
Gregory Boykin, Division Chief  
Division of Facility Management

\_\_\_\_\_  
(Date)

**This Contract form has been preapproved by the Office of the County Attorney and may not be modified without the concurrence of the Office of the County Attorney.**

**NAME AND SIGNATURE REQUIREMENTS FOR BIDS AND CONTRACTS**

The correct legal business name of the Offeror must be used. A trade name (i.e., a shortened or different name under which the firm does business) must not be used when the legal name is different. Corporations must have names that comply with State Law. The Offeror's signature must conform to the following: All signatures must be made by an authorized officer, partner, manager, or employee. The signing of an Offer or a Contract is a representation and certification by the person signing that the person is authorized to sign the Offer or Contract on behalf of the Offeror or Contractor.

**End of**

**CONSTRUCTION CONTRACT BETWEEN OWNER AND CONTRACTOR**



IFB #1109382  
**SPECIFICATIONS FOR ELEVATOR RENOVATION**  
**STRATHMORE MANSION**

**Performance Bond**

Bond No.: \_\_\_\_\_

\_\_\_\_\_, as surety ("Surety"), and \_\_\_\_\_

as principal ("Contractor"), enter into and execute this bond ("Performance Bond"), and bind themselves in favor of Montgomery County Maryland, as obligee ("Owner"), in the initial amount of \$XXX, XXX.XX(dollar value written out in words) which is 95% (ninety-five percent) of the Contract Sum (or such greater amount as the Contract Sum may be adjusted to from time to time in accordance with the Contract between the Contractor and Owner) (the "Penal Sum").

WHEREAS, the Contractor has executed a contract with the Owner dated \_\_\_\_\_ (the "Contract") for the \_\_\_\_\_ (the "Project") and,

WHEREAS, the Owner has required the Contractor to furnish this Performance Bond as a condition to executing the Contract with the Contractor;

NOW THEREFORE, the Surety and the Contractor, both jointly and severally, and for themselves, their heirs, administrators, executors, successors and assigns agree:

1. **CONTRACT INCORPORATED; SURETY AND CONTRACTOR BOUND FOR FULL PERFORMANCE.** The Contract is incorporated by reference and made a part of this bond. The Surety and the Contractor are bound for the full performance of the Contract including without exception all of the Contract Documents (as defined in the Contract) and all of their terms and conditions, both express and implied.
2. **OWNER'S AFFIDAVIT OF CONTRACTOR BREACH OR DEFAULT.** If the Owner shall provide to Surety the written affidavit of the Owner stating that the Contractor is in breach or default of the Contract, and that such breach or default remains uncured by the Contractor, then upon delivery of such affidavit to the Surety in the method for providing notices as set forth in Paragraph 7 below, Surety must promptly notify the Owner in writing which action it will take as permitted in Paragraph 3.
3. **SURETY'S OBLIGATION UPON DELIVERY OF OWNER'S AFFIDAVIT OF CONTRACTOR'S BREACH OR DEFAULT.** Upon the delivery of the Owner's affidavit of breach or default by the Contractor as provided in Paragraph 2 above, the Surety may promptly remedy the breach or default or must, within thirty (30) days, proceed to take one of the following courses of action:



**SPECIFICATIONS FOR ELEVATOR RENOVATION  
STRATHMORE MANSION**

- a. **Proceed Itself.** Complete performance of the Contract including correction of defective and nonconforming Work through its own contractors or employees, approved as being acceptable to the Owner, in the Owner's sole discretion, provided, however, that Owner's discretion to approve Surety's contractor will not be unreasonably withheld as to any contractor who would have qualified to offer a proposal on the Contract and is not affiliated (as defined in the General Conditions of Contract) with the Contractor. During this performance by the Surety the Owner will pay the Surety from its own funds only those sums as would have been due and payable to the Contractor under the Contract as and when they would have been due and payable to the Contractor in the absence of the breach or default not to exceed the amount of the remaining Contract balance less any sums due the Owner under the Contract. During this performance Surety's payment bond must remain in full force and effect; or
- b. **Tender a completing contractor acceptable to Owner.** Tender a contractor, approved as being acceptable to the Owner (in the Owner's sole discretion), together with a contract for fulfillment and completion of the Contract executed by the completing contractor, to the Owner for the Owner's execution. Owner's discretion to approve Surety's completing contractor will not be unreasonably withheld as to any contractor who would have qualified to offer a proposal on the Contract and is not affiliated (as defined in the General Conditions of Contract) with the Contractor. Owner's discretion to approve Contractor as the completing contractor, however, shall be in Owner's sole subjective discretion. Upon execution by the Owner of the contract for fulfillment and completion of the Contract, the completing contractor must furnish to the Owner a performance bond and a separate payment bond, each in the form of those bonds previously furnished to the Owner for the Project by the Contractor. Each such bond must be in the Penal Sum of the full cost to complete the Contract. The Owner will pay the completing contractor from its own funds only those sums as would have been due and payable to the Contractor under the Contract as and when they would have been due and payable to the Contractor in the absence of the breach or default not to exceed the amount of the remaining Contract balance less any sums due the Owner under the Contract. To the extent that the Owner is obligated to pay the completing contractor sums which would not have then been due and payable to the Contractor under the Contract (any sums in excess of the then remaining Contract balance less any sums due the Owner under the Contract), the Surety must pay to the Owner the full amount of those sums at the time the completing Contractor is tendered to the Owner so that the Owner can utilize those sums in making timely payment to the completing contractor; or

**SPECIFICATIONS FOR ELEVATOR RENOVATION  
STRATHMORE MANSION**

- c. **Tender the Full Penal Sum.** Tender to the Owner the full Penal Sum of the surety bond. The Owner will refund to the Surety without interest any unused portion not spent by the Owner procuring and paying a completing contractor or completing the Contract itself, plus the cost allowed under Section 4, after completion of the contract for fulfillment and completion of the Contract and the expiration of any applicable warranties; or
  - d. **Other Acts.** Take any other acts mutually agreed upon in writing by the Owner and the Surety.
  - e. **IT SHALL BE NO DEFENSE TO SURETY'S OBLIGATION TO UNDERTAKE ONE OF THE PRECEDING COURSES OF ACTION THAT THE CONTRACTOR CONTENDS THAT IT IS NOT IN BREACH OR DEFAULT OF THE CONTRACT, OR THAT THE NOTICE OF BREACH OR DEFAULT WAS DEFECTIVE, OR THAT THE CONTRACTOR HAS RAISED ANY OTHER CLAIM OF DEFENSE OR OFFSET, PROVIDED ONLY THAT SURETY HAS RECEIVED THE AFFIDAVIT OF THE OWNER AS SPECIFIED IN PARAGRAPH 2.**
4. **SURETY'S ADDITIONAL OBLIGATIONS.** In addition to those duties set forth herein above, the Surety must promptly pay the Owner (i) all losses, costs and expenses resulting from the Contractor's breach(es) or default(s), including, without limitation, fees, expenses and costs for architects, engineers, consultants, testing, surveying and attorneys, plus (ii) liquidated or actual damages, whichever may be provided for in the contract, for lost use of the Project, plus (iii) reprocurement costs and fees and expenses, plus (iv) costs incurred at the direction, request, or as a result of the acts or omissions of the Surety; provided that in no event shall Surety's liability exceed the Penal Sum of this Bond.
5. **SURETY'S WAIVER OF NOTICE.** The Surety waives notice of any Modifications to the Contract, including changes in the Contract Time, the Contract Sum, the amount of liquidated damages, or the Work to be performed.
6. **NO THIRD PARTY BENEFICIARIES.** The Surety provides this Performance Bond for the sole and exclusive benefit of the Owner and, if applicable, any dual obligee designated by attached rider, together with their heirs, administrators, executors, successors and assigns. No other party, person or entity has any rights against the Surety.
7. **METHOD OF NOTICE.** All notices to the Surety, the Contractor or the Owner must be given by Certified Mail, Return Receipt Requested, to the address set forth for each party below:

IFB #1109382  
**SPECIFICATIONS FOR ELEVATOR RENOVATION**  
**STRATHMORE MANSION**

**SURETY:**

Name: \_\_\_\_\_  
Attention: \_\_\_\_\_  
Street: \_\_\_\_\_  
City, State,  
Zip \_\_\_\_\_

**CONTRACTOR:**

Name: \_\_\_\_\_  
Attention: \_\_\_\_\_  
Street: \_\_\_\_\_  
City, State,  
Zip \_\_\_\_\_

**OWNER:**

Montgomery County Government  
Gregory Boykin, Chief  
Montgomery County Department of General Services  
Division of Facility Management  
1301 Seven Locks Road  
Rockville, MD 20854

with a copy to:

Office of the County Attorney  
Walter E. Wilson, Associate County Attorney  
101 Monroe Street, Third Floor  
Rockville, Maryland 20850

8. **STATUTE OF LIMITATIONS.** Any statutory limitation, which may be contractually superseded, to the contrary notwithstanding, any action hereon may be instituted so long as the applicable statute of limitations governing the Contract (including any warranty period) has not run or expired or within three (3) years following final completion of the Contract (including any warranty period) and acceptance of the Work performed under the Contract by the Owner, whichever is longer.
9. **RECITALS.** The recitals contained in this Performance Bond are incorporated by reference herein and are expressly made a part of this

**SPECIFICATIONS FOR ELEVATOR RENOVATION  
STRATHMORE MANSION**

Performance Bond.

10. **GOVERNING LAW.** This Performance Bond shall be governed by, and construed in accordance with the laws of the State of Maryland without regard to its conflict of laws provisions.
11. **VENUE.** In the event any legal action shall be filed upon this Performance Bond, venue shall lie exclusively in the Circuit Court for Montgomery County, Maryland.

**SIGNATURE PAGE FOLLOWS**

IFB #1109382  
**SPECIFICATIONS FOR ELEVATOR RENOVATION**  
STRATHMORE MANSION

SIGNATURE PAGE FOR PERFORMANCE BOND FOR  
CONTRACT No. 1109382

**Contractor**

**Surety**

\_\_\_\_\_  
(Typed Firm Name)

\_\_\_\_\_  
(Typed Firm Name)

\_\_\_\_\_  
(Seal)

\_\_\_\_\_  
(Seal)

By:

By:

\_\_\_\_\_  
(Signature)

\_\_\_\_\_  
(Signature)

\_\_\_\_\_  
(Printed Name)

\_\_\_\_\_  
(Printed Name)

\_\_\_\_\_  
(Title)

\_\_\_\_\_  
(Title)

\_\_\_\_\_  
(Address)

\_\_\_\_\_  
(Address)

\_\_\_\_\_  
(Date of Execution)

\_\_\_\_\_  
(Date of Execution)

IFB #1109382  
**SPECIFICATIONS FOR ELEVATOR RENOVATION**  
**STRATHMORE MANSION**

**Payment Bond**

Bond No: \_\_\_\_\_

\_\_\_\_\_, as surety ("Surety"), and \_\_\_\_\_ as principal ("Contractor"), enter into and execute this bond ("Payment Bond"), and bind themselves in favor of Montgomery County Government, as obligee ("Owner") in the amount of \$XXX,XXX.XX(dollar value written out in words) which is 95% (ninety-five percent) of the Contract Sum (or such greater amount as the Contract Sum may be adjusted to from time to time in accordance with the Contract between the Contractor and Owner) (the "Penal Sum").

WHEREAS, the Contractor has executed a contract with the Owner dated \_\_\_\_\_ (the "Contract") for the \_\_\_\_\_ (the "Project") and,

WHEREAS, the Owner has required the Contractor to furnish this Payment Bond containing the terms and conditions set forth herein as a condition to executing the Contract with the Contractor;

NOW THEREFORE, the Surety and the Contractor, both jointly and severally, and for themselves, their heirs, administrators, executors, successors and assigns agree:

1. The Contract is incorporated by reference and made a part of this Agreement. The Surety and the Contractor are bound for the full performance of the Contract including without exception all of the Contract Documents (as defined in the Contract) and all of their terms and conditions, both express and implied, and, without limitation, specifically including Contractor's obligation to pay for labor, materials, services and equipment provided in connection with the Contract performance;
2. For purposes of this Payment Bond, Beneficiary is defined as a person or entity who has actually provided labor, material, equipment, services or other items for use in furtherance of the Contract, labor and material being construed to include that part of water, gas, power, light, heat, oil, gasoline, telephone service or rental of equipment directly applicable to the Contract and having:
  - a. a direct contract with the Contractor; or
  - b. a direct contract with a subcontractor or sub-subcontractor of the Contractor; or

IFB #1109382  
**SPECIFICATIONS FOR ELEVATOR RENOVATION**  
**STRATHMORE MANSION**

- c. rights, under the laws applicable in Montgomery County, Maryland, to file a lien, a claim or notice of lien, or otherwise make a claim against the Project, the Site, or against funds held by the Owner, if the Project is, or were, subject to such filing.
3. The Surety is not obligated hereunder to a Beneficiary other than a Beneficiary having a direct contract with the Contractor unless such Beneficiary has given written notice of its claim to the Contractor and the Surety within the longer of:
  - a. ninety (90) days after such Beneficiary provided labor, material, equipment, services or other items for use in furtherance of the Contract; or,
  - b. the period of time under the laws applicable in Montgomery County, Maryland for (1) filing of a lien, claim of lien, or notice of lien, if the Project is, or were, subject to such filing, or (2) otherwise making a claim against the Project or against funds held by the Owner; stating the amount claimed and identifying, by name and address, the person or entity to whom such labor, material, equipment, services or other items were provided.
4. In no event is the Surety obligated hereunder for sums in excess of the Penal Sum.
5. Upon receipt of a claim from a Beneficiary hereunder, the Surety must promptly, and in no event later than forty-five (45) days after receipt of such claim, respond to such claim in writing (furnishing a copy of such response to the Owner) by:
  - a. making payment of all sums not in dispute; and,
  - b. stating the basis for disputing any sums not paid.

The failure of Surety to identify a specific defense to all or part of a claim shall not be deemed an admission of liability by Surety or otherwise constitute a waiver of any claims or defenses that the contractor and/or Surety may have or acquire as to such claim, including, without limitation the right to dispute such claim.

6. No action shall be commenced by a Beneficiary hereunder after the passage of the longer of one (1) year following final completion of the Contract (including any warranty period) and acceptance of the Work performed under the Contract by the Owner or any limitation period provided under the laws applicable in Montgomery County, Maryland.

**SPECIFICATIONS FOR ELEVATOR RENOVATION  
STRATHMORE MANSION**

7. The Surety waives notice of any Modifications to the Contract, including changes in the Contract Time, the Contract Sum, the amount of liquidated damages, or the Work to be performed.
8. All notices to the Surety, the Contractor or the Owner must be given by Certified Mail, Return Receipt Requested, to the address set forth for each party below:

**SURETY:**

Name: \_\_\_\_\_  
Attention: \_\_\_\_\_  
Street: \_\_\_\_\_  
City, State,  
Zip \_\_\_\_\_

**CONTRACTOR:**

Name: \_\_\_\_\_  
Attention: \_\_\_\_\_  
Street: \_\_\_\_\_  
City, State,  
Zip \_\_\_\_\_

**OWNER:**

Montgomery County Government  
**<Contract Administrator>**  
Montgomery County Government  
Gregory Boykin, Chief  
Montgomery County Department of General Services  
Division of Facility Management  
1301 Seven Locks Road  
Rockville, MD 20854

**with a copy to:**

Office of the County Attorney  
Walter E. Wilson, Associate County Attorney  
101 Monroe Street, Third Floor  
Rockville, Maryland 20850

9. The recitals contained in this Payment Bond are incorporated by reference



IFB #1109382  
**SPECIFICATIONS FOR ELEVATOR RENOVATION**  
**STRATHMORE MANSION**

herein and are expressly made a part of this Payment Bond.

10. This Payment Bond shall be governed by, and construed in accordance with the laws of the State of Maryland without regard to its conflict of laws provisions.
11. In the event any legal action shall be filed upon this Payment Bond, venue shall lie exclusively in the Circuit Court for Montgomery County, Maryland.

**SIGNATURE PAGE FOLLOWS**

IFB #1109382  
**SPECIFICATIONS FOR ELEVATOR RENOVATION**  
**STRATHMORE MANSION**

Signature Page for Payment Bond for Contract No. 1109382

**Contractor**

**Surety**

\_\_\_\_\_  
(Typed Firm Name)

\_\_\_\_\_  
(Typed Firm Name)

\_\_\_\_\_  
(Seal)

\_\_\_\_\_  
(Seal)

By:

By:

\_\_\_\_\_  
(Signature)

\_\_\_\_\_  
(Signature)

\_\_\_\_\_  
(Printed Name)

\_\_\_\_\_  
(Printed Name)

\_\_\_\_\_  
(Title)

\_\_\_\_\_  
(Title)

\_\_\_\_\_  
(Address)

\_\_\_\_\_  
(Address)

\_\_\_\_\_  
(Date of Execution)

\_\_\_\_\_  
(Date of Execution)

IFB #1109382  
**SPECIFICATIONS FOR ELEVATOR RENOVATION**  
**STRATHMORE MANSION**

**MANDATORY INSURANCE REQUIREMENTS**

MANDATORY INSURANCE REQUIREMENTS

*Elevator Modernization Strathmore Mansion, 10701 Rockville Pike, Rockville, MD*

Prior to the execution of the contract by the County, the proposed awardee/contractor and their contractors (if requested by County) must obtain, at their own cost and expense, the following *minimum* (not maximum) insurance coverage with an insurance company/companies licensed to conduct business in the State of Maryland and acceptable to the Division of Risk Management. This insurance must be kept in full force and effect during the term of this contract, including all extensions. The insurance must be evidenced by a certificate of insurance, and if requested by the County, the proposed awardee/contractor shall provide a copy of the insurance policies and additional insured endorsements. The minimum limits of coverage listed below shall not be construed as the maximum as required by contract or as a limitation of any potential liability on the part of the proposed awardee/contractor to the County nor shall failure to request evidence of this insurance in any way be construed as a waiver of proposed awardee / contractor's obligation to provide the insurance coverage specified. The Contractor's insurance shall be primary.

Commercial General Liability

A minimum limit of liability of *three million dollars (\$3,000,000) per occurrence* for bodily injury and property damage coverage per occurrence including the following coverages:

- Contractual Liability
- Premises and Operations
- Independent Contractors
- Products and Completed Operations during
- Broad Form Property Damage
- Personal Injury

Automobile Liability Coverage

A minimum limit of liability of *one million dollars (\$1,000,000)*, combined single limit, for bodily injury and property damage coverage per occurrence including the following:

- owned automobiles
- hired automobiles
- non-owned automobiles

Worker's Compensation/Employer's Liability

Meeting all statutory requirements of the State of Maryland Law and with the following minimum Employers' Liability limits: *Bodily Injury by Accident - \$100,000 each accident*

*Bodily Injury by Disease - \$500,000 policy limits*

*Bodily Injury by Disease - \$100,000 each employee*

Additional Insured

Montgomery County, Maryland, its elected and appointed officials, officers, consultants, agents and employees, must be included as an additional insured on Contractor's commercial general, automobile insurance, and contractor's excess/umbrella insurance if used to satisfy the

**SPECIFICATIONS FOR ELEVATOR RENOVATION  
STRATHMORE MANSION**

Contractor's minimum insurance requirements under this contract, for liability arising out of contractor's products, goods and services provided under this contract. The stipulated limits of coverage above shall not be construed as a limitation of any potential liability to Customer and failure to request evidence of this insurance shall in no way be construed as a waiver of Contractor's obligation to provide the minimum insurance coverage specified.

Policy Cancellation

Should any of the above policies be cancelled before the expiration date thereof, written notice must be delivered to the County in accordance with the policy provisions.

Certificate Holder

Montgomery County Government  
DGS / Facilities Management / Homer Bakhtiary  
1301 Seven Locks Road  
Rockville, MD 20854

IFB #1109382  
**SPECIFICATIONS FOR ELEVATOR RENOVATION**  
**STRATHMORE MANSION**

SUPPLEMENTAL TERMS AND CONDITIONS

**Delete:** 10.2.2. **Duration of General Warranty** is in its entirety.

**Replace With: R 10.2.2 Duration of General Warranty** The Contractor warrants and guarantees for two (2) years from Substantial Completion, or for a longer period that is otherwise expressly stated in the Contract Documents, the Work. This includes a Warranty and Guarantee against any and all defects for a minimum period of two (2) year from Substantial Completion or any longer period stated in the Contract Documents. The Contractor must correct any and all defects in material and/or workmanship which may appear during the Warranty and Guarantee period, or any defects that occur within two (2) year of Substantial Completion even if discovered more than two (2) year after Substantial Completion, by repairing (or replacing with new items or new materials, if necessary) any such defect at no cost to the Owner, within a reasonable period of time, and to the Owner's satisfaction.

All Insurance requirements and Bonds are to be kept in full force and effect until the end of the 2 year Warranty period.

END SUPPLEMENTAL TERMS AND CONDITION

IFB #1109382  
**SPECIFICATIONS FOR ELEVATOR RENOVATION**  
**STRATHMORE MANSION**

Prevailing Wage Requirements for Construction Contract Addendum to the General  
Conditions of Contract between County and Contractor

The Contractor and all Subcontractors must comply with the Prevailing Wage Law contained in Chapters 11B-33C and 20-75 of the Montgomery County Code. Prevailing wage means the wage rate paid by employers that is determined by a governmental authority, based upon a particular geographic area, for a given class of labor and type of project. The purpose of a prevailing wage is to ensure that construction workers who work on public works contracts are paid the going rate for their services. The prevailing wage rates are established by the State of Maryland and apply to all of the Contractor's employees and any and all Subcontractors. The Contractor and all Subcontractors must comply with all of the requirements of the Prevailing Wage Law including, but not limited to, the following:

1. Pay employees the prescribed rate as annually established by the State of Maryland Commissioner of Labor and Industry; the prevailing wage rates in effect on the date a solicitation is issued will apply throughout the term of a contract resulting from that solicitation.
2. Pay employees overtime for work more than 10 hours in any single day, work more than 40 hours in a work week, or work on Sunday or legal holiday;
3. Classify employees in their proper work classification in conformance with the schedule established by the State of Maryland Commissioner of Labor and Industry;
4. Electronically submit payroll records through [www.LCPTracker.net](http://www.LCPTracker.net), within 14 days after the end of each payroll period, to verify that Prevailing Wage rates have been paid to employees. The payroll records must include the following:
  - A. The name, address and telephone number of the Contractor or Subcontractor;
  - B. The name and location of the job;
  - C. Each employee's:
    - a. Name;
    - b. Current address unless previously reported;
    - c. Specific work classification;
    - d. Daily straight time and overtime hours;
    - e. Total straight time and overtime hours for the payroll period;
    - f. Rate of pay;
    - g. Fringe benefits by type and amount;
    - h. Gross wages.
5. If a Contractor or any Subcontractors are late in submitting copies of any payroll records required to be submitted under the Prevailing Wage Law, the County may deem Contractor's invoice(s) submitted to the County for payment unacceptable

IFB #1109382  
**SPECIFICATIONS FOR ELEVATOR RENOVATION**  
**STRATHMORE MANSION**

until the Contractor and Subcontractors provide the required records; and, the County may postpone processing payments otherwise due under the Contract or under an agreement to finance the Contract;

6. The Contractor and all Subcontractors must retain all payroll records for a period not less than five (5) years after the Work is completed;
7. The County may inspect the payroll records at any reasonable time and as often as it deems necessary;
8. The County may perform random or regular audits and investigate any complaint of a violation of the Prevailing Wage Law;
9. In the event the County determines that a provision of the Prevailing Wage Law has been violated, the County may withhold payment to the Contractor in an amount sufficient to pay each employee of the Contractor or any Subcontractors the full amount of wages due under the Prevailing Wage Law, and an amount sufficient to satisfy a liability of a Contractor or any Subcontractors for liquidated damages as provided under the Prevailing Wage Law, pending a final decision on the violation by the County;
10. Contractor may appeal a written decision of the Director, Office of Procurement, that the Contractor violated a provision of the Prevailing Wage Law to the Chief Administrative Officer (“CAO”), within ten (10) days after receiving a copy of the decision. The CAO must designate a hearing officer to conduct a hearing upon receipt of a timely appeal. If the Contractor does not appeal a written decision within ten (10) days after receipt, the decision of the Director, becomes final and binding;
11. Contractor and all Subcontractors must not discharge, or otherwise retaliate against, an employee for asserting any right under the Prevailing Wage Law or for filing a complaint of a violation;
12. An aggrieved employee is a third-party beneficiary of this Contract and the employee may by civil action recover the difference between the prevailing wage for the type of work performed and the amount actually received, with interest and a reasonable attorney’s fee; and
13. Each Contract subject to the Prevailing Wage Law may specify the payment of liquidated damages to the County by the Contractor and any Subcontractors for any noncompliance with the Prevailing Wage Law. Liquidated damages are: \$10 for each calendar day that the payroll records are late; \$20 per day for each day that an employee is misclassified; and \$50 per violation of the requirement to post the prevailing wage rates at the work site.

**SPECIFICATIONS FOR ELEVATOR RENOVATION  
STRATHMORE MANSION**

14. Where the initial Contract Sum is below the \$500,000.00 threshold, but it is subsequently increased and exceeds the \$500,000.00 threshold due to an approved Contract Modification, the amount of any such Contract Modification that causes the Contract Sum to exceed the \$500,000.00 threshold is subject to the Prevailing Wage Law.
15. The Contractor and all Subcontractors must post a clearly legible statement of each prevailing wage rate in a prominent and easily accessible place at the Work Site during the entire time Work is being performed, in English and any other language that is primarily spoken by the employees, at the Work Site.



IFB #1109382  
**SPECIFICATIONS FOR ELEVATOR RENOVATION**  
**STRATHMORE MANSION**

**SECTION 00 8000 – MASTER SCHEDULE AND CRITICAL CONTRACT COMPLETION PERIODS**

(Durations are in Calendar Days)

**Phase 1 - Preconstruction Activities**

Approval of Initial Submittals 60 days after receipt of Notice to Proceed # 1 (\*)

(\*) Initial Submittals, as defined by Subsection 9.1.2 of the General Conditions of Construction Contract (GCCC), must be submitted by the Contractor within the time periods specified in GCCC Subsection 9.1.2. All initial Submittals must be approved by the Architect/Engineer and Owner prior to Owner's issuance of Notice to Proceed # 2 for construction. Therefore, the referenced time period for this Phase is approximate and dependent on several factors including the quality of the Submittals.

List of Subcontractors: The time periods referenced in GCCC Subsection 6.1.1 begin upon issuance of Notice to Proceed # 1. The name of all subcontractors working in the first 30 days after Notice to Proceed # 2 must be submitted within 10 days of Notice to Proceed # 1 - and must be approved by the County before issuance of Notice to Proceed # 2.

Other activities during Phase 1 include:

- Pre-construction meetings with Owner and/or regulatory agencies,
- Demarcation of Limits of Disturbance (LOD) for inspection and approval by regulatory agencies,
- Tree protection as required by regulatory agencies,
- Preparation and submission of other Submittals for A/E review, and
- Other administrative activities as required by regulatory agencies.

Work on the Site, beyond those activities specifically identified above, is not permitted until issuance of Notice to Proceed # 2.

**Phase 2 - Construction**

Substantial Completion of the Work 140 days after Date of Commencement in Notice to Proceed # 2  
Final Completion 30 days after Substantial Completion

Note: The Date of Commencement is the date established in Notice to Proceed # 1 upon which the Contract Time begins to run; or if no date is established, then it is the date of Notice to Proceed # 2. The Contract Time is the total period of time between the Date of Commencement and Substantial Completion of the Work.

**End of SECTION 00 8000**  
**MASTER SCHEDULE AND CRITICAL CONTRACT COMPLETION PERIODS**

**IFB No. 1109382**  
**STRATHMORE MANSION**

**GENERAL CONDITIONS OF CONSTRUCTION**  
**CONTRACT**

**SUMMARY OF CONTENTS**

- 1. DEFINITIONS AND USE OF TERMS
- 2. THE CONTRACT
- 3. THE OWNER
- 4. ADMINISTRATION OF THE CONTRACT
- 5. CONTRACTOR
- 6. SUBCONTRACTORS AND SUPPLIERS
- 7. WORK BY OWNER AND BY OTHERS
- 8. PROTECTION OF PERSONS AND PROPERTY
- 9. SUBMITTALS
- 10. QUALITY CONTROL PLAN, COMMISSIONING REPORT & WARRANTIES
- 11. TIME
- 12. CHANGES
- 13. PAYMENTS
- 14. SUBSTANTIAL AND FINAL COMPLETION
- 15. RIGHTS AND REMEDIES
- 16. CONTRACT DISPUTES
- 17. INSURANCE AND BONDS
- 18. NONDISCRIMINATION IN EMPLOYMENT
- 19. STATUTORY REQUIREMENTS
- 20. MISCELLANEOUS PROVISIONS

**TABLE OF CONTENTS**

|   |    |
|---|----|
| ARTICLE 1: DEFINITIONS AND USE OF TERMS .....     | 87 |
| 1.1 DEFINED TERMS .....                           | 87 |
| 1.1.1 Addendum.....                               | 87 |
| 1.1.2 Affiliated Entity .....                     | 87 |
| 1.1.4 Allowance .....                             | 87 |
| 1.1.5 Application for Payment.....                | 87 |
| 1.1.6 Architect, Architect/Engineer, A/E.....     | 87 |
| 1.1.7 Bid.....                                    | 87 |
| 1.1.8 Bid Documents .....                         | 87 |
| 1.1.9 Bid, Performance and Payment Bonds .....    | 87 |
| 1.1.10 Certificate for Payment.....               | 87 |
| 1.1.11 Certificate of Final Completion.....       | 87 |
| 1.1.12 Certificate of Insurance .....             | 87 |
| 1.1.13 Certificate of Substantial Completion..... | 88 |
| 1.1.14 Change Order.....                          | 88 |

|  |    |
|--|----|
| 1.1.15 Contract                            | 88 |
| 1.1.16 Contract Administrator              | 88 |
| 1.1.17 Contract Amendment                  | 88 |
| 1.1.18 Contract Documents                  | 88 |
| 1.1.19 Contract Sum                        | 88 |
| 1.1.20 Contract Time                       | 88 |
| 1.1.21 Contractor                          | 88 |
| 1.1.22 Coordination Drawings               | 88 |
| 1.1.23 Date of Commencement                | 88 |
| 1.1.24 Date of Substantial Completion      | 88 |
| 1.1.25 Day                                 | 88 |
| 1.1.26 Defective or Nonconforming Work     | 88 |
| 1.1.27 Delay                               | 89 |
| 1.1.28 Department                          | 89 |
| 1.1.29 Director                            | 89 |
| 1.1.30 Drawings                            | 89 |
| 1.1.31 Field Order                         | 89 |
| 1.1.32 Final Completion                    | 89 |
| 1.1.33 Geotechnical Studies                | 89 |
| 1.1.34 Hazardous Materials                 | 89 |
| 1.1.35 Instructions to Bidders or Offerors | 90 |
| 1.1.36 Invitation for Bids                 | 90 |
| 1.1.37 Laws and Regulations                | 90 |
| 1.1.38 Liquidated Damages                  | 90 |
| 1.1.39 Modification                        | 90 |
| 1.1.40 Notice to Proceed                   | 90 |
| 1.1.41 Offer                               | 90 |
| 1.1.42 Offeror                             | 90 |
| 1.1.43 Or-Equal Item                       | 90 |
| 1.1.44 Owner                               | 90 |
| 1.1.45 Product Data                        | 90 |
| 1.1.46 Progress Schedule                   | 90 |
| 1.1.47 Project                             | 90 |
| 1.1.48 Project Manager                     | 90 |
| 1.1.49 Project Manual                      | 90 |
| 1.1.50 Proposal                            | 91 |
| 1.1.51 Proposal Documents                  | 91 |
| 1.1.52 Punch List                          | 91 |
| 1.1.53 Record Documents                    | 91 |
| 1.1.54 Referenced Standards                | 91 |
| 1.1.55 Request for Proposal                | 91 |
| 1.1.56 Samples                             | 91 |
| 1.1.57 Schedule of Submittals              | 91 |
| 1.1.58 Schedule of Values                  | 91 |
| 1.1.59 Separate Contractor                 | 91 |
| 1.1.60 Shop Drawings                       | 91 |
| 1.1.61 Site                                | 91 |

|   |           |
|---|-----------|
| 1.1.62 Site Survey  | 91        |
| 1.1.63 Solicitation   | 92        |
| 1.1.64 Specifications   | 92        |
| 1.1.65 Subcontractor  | 92        |
| 1.1.66 Submittals   | 92        |
| 1.1.67 Substantial Completion                                       | 92        |
| 1.1.68 Substitution   | 92        |
| 1.1.69 Sub-subcontractor  | 92        |
| 1.1.70 Superintendent   | 92        |
| 1.1.71 Supplemental Conditions                                      | 92        |
| 1.1.72 Supplier   | 92        |
| 1.1.73 Surety   | 92        |
| 1.1.74 Taxes  | 92        |
| 1.1.75 Not Used   | 93        |
| 1.1.76 Unit Prices  | 93        |
| 1.1.77 Warranties and Guarantees                                    | 93        |
| 1.1.78 Work   | 93        |
| <b>1.2 USE OF TERMS</b>   | <b>93</b> |
| 1.2.1 Singular and Plural   | 93        |
| 1.2.2 Technical Terms and Trade Usage                               | 93        |
| 1.2.3 Titles and Headings   | 93        |
| <b>ARTICLE 2: THE CONTRACT</b>                                      | <b>93</b> |
| <b>2.1 AGREEMENT</b>  | <b>93</b> |
| 2.1.1 Changes   | 93        |
| 2.1.2 Documents Excluded from the Contract                          | 93        |
| <b>2.2 ORGANIZATION AND INTENT</b>                                  | <b>93</b> |
| 2.2.1 Contract Documents Complementary                              | 93        |
| 2.2.2 Intent to Require Completed Project                           | 93        |
| 2.2.3 Work Required if Reasonably Inferable                         | 93        |
| 2.2.4 Organization of Drawings and Specifications                   | 93        |
| <b>2.3 REFERENCED STANDARDS</b>                                     | <b>94</b> |
| 2.3.1 Standards Incorporated  | 94        |
| 2.3.2 Availability of Referenced Standards                          | 94        |
| 2.3.3 Precedence of Contract Documents Over<br>Referenced Standards | 94        |
| <b>2.4 OWNERSHIP AND USE OF DOCUMENTS</b>                           | <b>94</b> |
| 2.4.1 Copies Furnished  | 94        |
| 2.4.2 Ownership of Documents  | 94        |
| 2.4.3 Copyright and Other Reserved Rights                           | 94        |
| 2.4.4 Use and Reproduction of Documents                             | 94        |
| 2.4.5 Record Documents  | 94        |
| 2.4.6 Return of Documents   | 94        |

|   |           |
|---|-----------|
| <b>ARTICLE 3: THE OWNER</b> -----   | <b>94</b> |
| <b>3.1 OWNER’S REPRESENTATIVES</b> -----                                      | <b>94</b> |
| 3.1.1 Designated Representatives-----   | 94        |
| 3.1.2 Representative of Legal Owner-----                                      | 95        |
| <b>3.2 PROJECT INFORMATION</b> -----  | <b>95</b> |
| 3.2.1 Site Surveys -----  | 95        |
| 3.2.2 Site and Physical Data -----  | 95        |
| 3.2.3 Reliance by Contractor -----  | 95        |
| <b>3.3 OWNER RESPONSIBILITIES</b> -----                                       | <b>95</b> |
| 3.3.1 Access to Site-----   | 95        |
| 3.3.2 Permits and Fees -----  | 95        |
| <b>ARTICLE 4: ADMINISTRATION OF THE CONTRACT</b> -----                        | <b>96</b> |
| <b>4.1 CONTRACT ADMINISTRATION</b> -----                                      | <b>96</b> |
| 4.1.1 Administration by Owner -----   | 96        |
| 4.1.2 Contract Administrator Limitations of Authority -----                   | 96        |
| 4.1.3 Owner’s Representatives -----   | 96        |
| <b>4.2 CONSTRUCTION ADMINISTRATION</b> -----                                  | <b>96</b> |
| 4.2.1 Performance of Construction Administration -----                        | 96        |
| 4.2.2 Status of Architect/Engineer-----                                       | 96        |
| 4.2.3 Owner’s Project Manager Limitations of<br>Authority -----               | 96        |
| 4.2.4 Communications -----  | 96        |
| 4.2.5 Change in Architect/Engineer’s Duties -----                             | 97        |
| 4.2.6 Change of Architect/Engineer-----                                       | 97        |
| 4.2.7 Timeliness of Construction Administration<br>Services -----             | 97        |
| <b>4.3 ADMINISTRATION OF CONSTRUCTION</b> -----                               | <b>97</b> |
| 4.3.1 Interpretation and Clarification of Drawings and<br>Specifications----- | 97        |
| 4.3.2 Standard of Interpretation -----  | 97        |
| 4.3.3 Interpretations and Decisions by Owner -----                            | 97        |
| 4.3.4 Acceptability of Superintendent and Key<br>Personnel-----               | 97        |
| 4.3.5 Approval of Subcontractors and Suppliers -----                          | 98        |
| 4.3.6 Approval of Submittals -----  | 98        |
| 4.3.7 Site Visits -----   | 98        |
| 4.3.8 Rejection of Work-----  | 98        |
| 4.3.9 Additional Inspection, Testing or Specific<br>Approvals-----            | 98        |
| 4.3.10 Authority to Stop or Suspend Work -----                                | 98        |
| 4.3.11 Review of Applications for Payment -----                               | 98        |

|   |            |
|---|------------|
| 4.3.12 Changes in the Work-----   | 98         |
| 4.3.13 Substantial and Final Completion-----  | 98         |
| 4.3.14 Recommendations on Payments, Changes,<br>Claims and Disputes-----  | 98         |
| <b>4.4 LIMITATIONS OF OWNER’S AND<br/>ARCHITECT/ENGINEER’S RESPONSIBILITIES -----</b>   | <b>98</b>  |
| 4.4.1 Charge or Control-----  | 98         |
| 4.4.2 Actions not to Relieve Contractor -----   | 99         |
| 4.4.3 Responsibility for Others -----   | 99         |
| 4.4.4 Inspection, Testing or Approval and Rejection<br>of Work -----  | 99         |
| 4.4.5 Stopping or Suspension of Work -----  | 99         |
| 4.4.6 Payments -----  | 99         |
| 4.4.7 Occupancy or Use -----  | 99         |
| 4.4.8 Certificate of Substantial or Final Completion -----  | 99         |
| <b>ARTICLE 5: CONTRACTOR-----</b>   | <b>99</b>  |
| <b>5.1 REVIEW OF CONTRACT DOCUMENTS AND FIELD<br/>    CONDITIONS -----</b>  | <b>99</b>  |
| 5.1.1 Review of Site Conditions -----   | 99         |
| 5.1.2 Review of Contract Documents-----   | 99         |
| 5.1.3 Field Measurements and Site Conditions -----  | 99         |
| 5.1.4 Inspection of Work -----  | 99         |
| 5.1.5 Compliance of Contract Documents with Laws<br>and Regulations and Referenced Standards----                                  | 100        |
| 5.1.6 Notice of Errors-----   | 100        |
| 5.1.7 Risk of Performance-----  | 100        |
| <b>5.2 LEGAL REQUIREMENTS-----</b>  | <b>100</b> |
| 5.2.1 Compliance with Laws, Regulations and Orders ----   | 100        |
| 5.2.2 Taxes-----  | 100        |
| 5.2.3 Permits and Fees -----  | 100        |
| 5.2.4 Compliance with U.S. Green Building Council’s<br>Leadership in Energy and Environmental<br>Design (LEED) Requirements ----- | 100        |
| <b>5.3 CONTRACTOR’S RESPONSIBILITY FOR PERFORMANCE ----</b>   | <b>101</b> |
| 5.3.1 Assignment, Scheduling and Coordination -----   | 101        |
| 5.3.2 Construction Means and Methods-----   | 101        |
| 5.3.3 Discipline at the Site-----   | 101        |
| 5.3.4 Responsibility for Subordinates-----  | 101        |
| 5.3.5 Obligations Not Relieved-----   | 101        |
| <b>5.4 SUPERINTENDENCE -----</b>  | <b>101</b> |
| 5.4.1 Superintendent -----  | 101        |
| 5.4.2 Acceptability of Key Personnel -----  | 101        |
| 5.4.3 Communications with Superintendent and  |            |

|  |            |
|--|------------|
| Project Manager and Owner's Representative and/or the Architect/Engineer -----               | 102        |
| <b>5.5 LABOR, MATERIALS AND EQUIPMENT -----</b>  | <b>102</b> |
| 5.5.1 Labor, Materials and Equipment Provided by Contractor -----                            | 102        |
| 5.5.2 Royalties and License Fees -----   | 102        |
| 5.5.3 Compliance with Contract Documents, Approved Submittals, and Interpretations -----     | 102        |
| 5.5.4 Compliance with Manufacturers' Instructions -----                                      | 102        |
| 5.5.5 Labor -----  | 102        |
| 5.5.6 Allowances -----   | 102        |
| 5.5.7 Adjustments for Allowances -----   | 103        |
| <b>5.6 CONSTRUCTION OPERATIONS -----</b>   | <b>103</b> |
| 5.6.1 Use of Site -----  | 103        |
| 5.6.2 Benchmarks and Layout of Work -----  | 103        |
| 5.6.3 Working Hours -----  | 104        |
| 5.6.4 Noise Ordinance -----  | 104        |
| 5.6.5 Temporary Facilities -----   | 104        |
| 5.6.6 Cutting, Patching and Finishing -----  | 104        |
| 5.6.7 Cleaning Up -----  | 104        |
| 5.6.8 Utilities -----  | 104        |
| 5.6.9 Air Pollution Control -----  | 106        |
| <b>ARTICLE 6: SUBCONTRACTORS AND SUPPLIERS -----</b>   | <b>106</b> |
| <b>6.1 SELECTION AND RIGHT OF REJECTION -----</b>  | <b>106</b> |
| 6.1.1 Identification of Subcontractors and Suppliers -----                                   | 106        |
| 6.1.2 Qualification of Subcontractors -----  | 106        |
| 6.1.3 Acceptance of Subcontractors and Suppliers -----                                       | 107        |
| 6.1.4 Use of Acceptable Subcontractors and Suppliers -----                                   | 107        |
| 6.1.5 Owner's Right to Require Removal -----   | 107        |
| 6.1.6 Replacement Subcontractors and Suppliers -----   | 107        |
| <b>6.2 SUBCONTRACTUAL RELATIONS -----</b>  | <b>107</b> |
| 6.2.1 Subcontracts Required -----  | 107        |
| 6.2.2 Copies to be Furnished by Contractor -----   | 107        |
| 6.2.3 Subcontract Provisions -----   | 107        |
| <b>6.3 PAYMENTS TO SUBCONTRACTORS AND SUPPLIERS -----</b>                                    | <b>108</b> |
| 6.3.1 Payments by Contractor to Subcontractors and Suppliers -----                           | 108        |
| 6.3.3 Substantial Completion Payment and Final Payment to Subcontractors and Suppliers ----- | 108        |
| 6.3.5 Information Regarding Payments -----   | 108        |

|  |            |
|--|------------|
| 6.3.6 Responsibility for Payment to Subcontractors-----                          | 108        |
| <b>6.4 CONTINGENT ASSIGNMENT OF SUBCONTRACTS AND<br/>PURCHASE ORDERS -----</b>   | <b>109</b> |
| 6.4.1 Assignment-----  | 109        |
| 6.4.2 Election by Owner-----   | 109        |
| 6.4.3 Rights of Surety-----  | 109        |
| 6.4.4 Liability for Prior Obligations-----                                       | 109        |
| <b>ARTICLE 7: WORK BY OWNER AND BY OTHERS -----</b>                              | <b>109</b> |
| <b>7.1 OTHER WORK AT THE SITE-----</b>   | <b>109</b> |
| 7.1.1 Owner’s Rights Reserved-----   | 109        |
| 7.1.2 Identification of Work by Others-----                                      | 109        |
| 7.1.3 Coordination of Other Work-----  | 109        |
| 7.1.4 Construction Schedules-----  | 109        |
| 7.1.5 Communications through Owner -----   | 110        |
| <b>7.2 RESPONSIBILITY OF CONTRACTOR-----</b>                                     | <b>110</b> |
| 7.2.1 Contractor to Afford Access to Others-----                                 | 110        |
| 7.2.2 Connection with Other Work-----  | 110        |
| 7.2.3 Inspection and Notice of Unsuitability -----                               | 110        |
| 7.2.4 Cutting, Patching and Finishing of Work by<br>Others-----                  | 110        |
| 7.2.5 Remedy of Damage to Work by Others -----                                   | 110        |
| <b>7.3 MUTUAL RESPONSIBILITY OF THE OWNER AND<br/>SEPARATE CONTRACTORS -----</b> | <b>110</b> |
| 7.3.1 Responsibility for Cleaning Up -----                                       | 110        |
| 7.3.2 Claims Involving Separate Contractors-----                                 | 110        |
| <b>ARTICLE 8: PROTECTION OF PERSONS AND PROPERTY -----</b>                       | <b>111</b> |
| <b>8.1 RESPONSIBILITY FOR SAFETY -----</b>                                       | <b>111</b> |
| 8.1.1 Responsibility for Site Safety-----  | 111        |
| 8.1.2 Appointment of Safety Officer-----   | 111        |
| 8.1.3 Compliance with Legal Requirements-----                                    | 111        |
| <b>8.2 SAFETY OF PERSONS AND PROPERTY-----</b>                                   | <b>111</b> |
| 8.2.1 Protections Required-----  | 111        |
| 8.2.2 Notices and Safeguards -----   | 111        |
| 8.2.3 Loading-----   | 111        |
| 8.2.4 Hazardous Activities-----  | 111        |
| 8.2.5 Qualified Personnel-----   | 112        |
| 8.2.6 Emergencies-----   | 112        |
| 8.2.7 Notice of Injury or Damage -----   | 112        |
| 8.2.8 Remedy of Property Damage -----  | 112        |
| 8.2.9 Responsibility for Site Security-----                                      | 112        |



|  |     |
|--|-----|
| 8.3 HAZARDOUS MATERIALS -----  | 112 |
| 8.3.1 Disclosure, Identification and Handling -----  | 112 |
| 8.3.2 Discovery of Hazardous Materials at the Site-----  | 113 |
| 8.3.3 Investigation and Remediation -----  | 113 |
| 8.3.4 Resumption of Work-----  | 113 |
| 8.3.5 Adjustments for PCBs and Asbestos -----  | 113 |
| 8.4 INDEMNIFICATION -----  | 113 |
| 8.4.1 Indemnity and Duty to Defend-----  | 113 |
| 8.4.2 Effect of Limitations on Statutory Benefits -----  | 114 |
| 8.4.3 Limitation as to Negligence of Indemnitee(s)-----  | 114 |
| 8.4.3 Other Rights of Indemnity -----  | 114 |
| ARTICLE 9: SUBMITTALS-----   | 114 |
| 9.1 SUBMITTALS REQUIRED-----   | 114 |
| 9.1.1 Precontract Submittals -----   | 114 |
| 9.1.2 Initial Submittals -----   | 114 |
| 9.1.3 Submittals During Construction-----  | 114 |
| 9.1.4 Closing Submittals -----   | 115 |
| 9.1.5 Purpose of Submittals -----  | 115 |
| 9.1.6 Performance of Work-----   | 115 |
| 9.2 SUBMISSION, REVIEW AND APPROVAL OF SUBMITTALS---   | 115 |
| 9.2.1 Contractor's Submission -----  | 115 |
| 9.2.2 Verification of Information in Submittals-----   | 115 |
| 9.2.3 Identification of Submittals-----  | 115 |
| 9.2.4 Deviations from Contract Requirements -----  | 115 |
| 9.2.5 Return Without Action -----  | 116 |
| 9.2.6 Review and Action by Architect/Engineer -----  | 116 |
| 9.2.7 Scope of Review -----  | 116 |
| 9.2.8 Correction and Resubmission -----  | 116 |
| 9.2.9 Identification of Revisions-----   | 116 |
| 9.2.10 Responsibility for Deviations, Revisions,<br>Errors<br>and Omissions in Submittals----- | 116 |
| 9.2.11 Professional Certifications -----   | 116 |
| 9.2.12 Submittals for Finishes -----   | 116 |
| ARTICLE 10: QUALITY CONTROL PLAN, COMMISSIONING REPORT AND<br>WARRANTIES-----                  | 117 |
| 10.1 QUALITY CONTROL PLAN AND COMMISSIONING<br>REPORT -----                                    | 117 |
| 10.1.1 Quality Control Plan-----   | 117 |
| 10.1.2 Commissioning Plan-----   | 117 |
| 10.2 GENERAL WARRANTY AND SPECIAL WARRANTIES -----   | 117 |

|        |  |     |
|--------|--|-----|
| 10.2.1 | General Warranty .....   | 117 |
| 10.2.2 | Duration of General Warranty.....  | 117 |
| 10.2.3 | Relation to Specific Correction Provisions and<br>Other Remedies .....     | 117 |
| 10.2.4 | Additional or Special Warranties .....                                     | 117 |
| 10.3   | OBSERVATION AND INSPECTION OF WORK .....                                   | 117 |
| 10.3.1 | Access to Work .....   | 117 |
| 10.3.2 | Site Visits .....  | 117 |
| 10.3.3 | Responsibility of Contractor .....   | 117 |
| 10.4   | UNCOVERING OF WORK.....  | 117 |
| 10.4.1 | Uncovering of Prematurely Covered Work.....                                | 117 |
| 10.4.2 | Uncovering of Other Covered Work.....                                      | 118 |
| 10.5   | TESTS, INSPECTIONS AND APPROVALS BY OTHERS .....                           | 118 |
| 10.5.1 | Required Tests, Inspections and Approvals .....                            | 118 |
| 10.5.2 | Tests and Inspections by Owner .....                                       | 118 |
| 10.5.3 | Scheduling of Tests, Inspections and<br>Approvals.....                     | 118 |
| 10.5.4 | Additional Tests, Inspections and Specific<br>Approvals.....               | 118 |
| 10.5.5 | Other Tests, Inspections and Specific<br>Approvals Required by Owner ..... | 119 |
| 10.5.6 | Notice to Contractor .....   | 119 |
| 10.5.7 | Observation of Tests, Inspections or<br>Approvals.....                     | 119 |
| 10.5.8 | Certificates of Testing, Inspection and<br>Approval .....                  | 119 |
| 10.5.9 | Costs of Re-Testing, Inspection and Approval .....                         | 119 |
| 10.6   | REJECTION AND CORRECTION OF WORK .....                                     | 119 |
| 10.6.1 | Rejection of Nonconforming Work.....                                       | 119 |
| 10.6.2 | Contractor to Correct or Replace Rejected<br>Work.....                     | 119 |
| 10.6.3 | Acceptance of Defective or Nonconforming<br>Work.....                      | 119 |
| 10.6.4 | Removal of Defective or Nonconforming Work .....                           | 119 |
| 10.6.5 | Contractor to Bear Cost to Correct or Replace<br>Other Work .....          | 120 |
| 10.6.6 | Failure to Correct or Replace .....  | 120 |
| 10.6.7 | Artistic Decisions .....   | 120 |
| 10.7   | SPECIFIC CORRECTION OF WORK.....   | 120 |
| 10.7.1 | Specific Correction Period.....  | 120 |
| 10.7.2 | Specific Correction Required .....   | 120 |
| 10.7.3 | Notice and Demand for Specific Correction<br>Obligation .....              | 120 |

|  |            |
|--|------------|
| 10.7.4 Extension of Specific Correction Obligation -----     | 120        |
| 10.7.5 Inspection Prior to Warranty Expiration -----         | 120        |
| 10.7.6 Effect on Other Remedies-----                         | 121        |
| <b>ARTICLE 11: TIME -----</b>                                | <b>121</b> |
| <b>11.1 COMMENCEMENT -----</b>                               | <b>121</b> |
| 11.1.1 Date of Commencement and Notice to Proceed ---        | 121        |
| 11.1.2 Preconstruction Conference-----                       | 121        |
| 11.1.3 Commencement of Work at the Site-----                 | 121        |
| <b>11.2 CONSTRUCTION SCHEDULES-----</b>                      | <b>121</b> |
| 11.2.1 Contractor's Progress Schedule -----                  | 121        |
| 11.2.2 Requirements of the Progress Schedule -----           | 121        |
| 11.2.3 Coordination with Other Schedules -----               | 126        |
| 11.2.4 Review and Approval of Schedules -----                | 126        |
| 11.2.5 Schedule of Submittals -----                          | 126        |
| <b>11.3 PROJECT PROGRESS -----</b>                           | <b>127</b> |
| 11.3.1 Contract Time Reasonable-----                         | 127        |
| 11.3.2 Time is of Essence -----                              | 127        |
| 11.3.3 Contractor to Proceed Expeditiously -----             | 127        |
| 11.3.4 Conformance to Schedules -----                        | 127        |
| 11.3.5 Progress Record -----                                 | 127        |
| 11.3.6 Substantial Completion Within Contract Time-----      | 127        |
| 11.3.7 No Damages for Prevention of Early<br>Completion----- | 127        |
| 11.3.8 Acceleration to Comply with Schedule-----             | 127        |
| 11.3.9 Acceleration of Schedule -----                        | 127        |
| <b>11.4 SUSPENSION OR STOPPAGE OF WORK -----</b>             | <b>127</b> |
| 11.4.1 Owner's Right to Stop the Work -----                  | 127        |
| 11.4.2 Owner's Right to Suspend Work for<br>Convenience----- | 128        |
| 11.4.3 Disputes Involving Non-payment-----                   | 128        |
| <b>11.5 DELAYS -----</b>                                     | <b>128</b> |
| 11.5.1 Excusable Delays -----                                | 128        |
| 11.5.2 Compensable Delays -----                              | 128        |
| 11.5.3 Unexcused Delays -----                                | 128        |
| <b>11.6 TIME AND RELATED COST ADJUSTMENTS -----</b>          | <b>128</b> |
| 11.6.1 Notice of Delay -----                                 | 128        |
| 11.6.2 Continuing Delay-----                                 | 129        |
| 11.6.3 Request for an Increase in Contract Time-----         | 129        |
| 11.6.4 Concurrent Delay -----                                | 129        |
| 11.6.5 Supporting Documentation-----                         | 129        |
| 11.6.6 Additional Time for Unusually Severe Weather ----     | 130        |

|   |     |
|---|-----|
| 11.6.7 Strikes and Labor Disputes -----   | 130 |
| 11.6.8 Review and Adjustment of Schedules-----                                      | 131 |
| 11.6.9 Limitation on Adjustments-----   | 131 |
| 11.6.10 Denial of Adjustments in Time or Money -----                                | 132 |
| 11.7 DAMAGES FOR DELAY-----   | 132 |
| 11.7.1 Delay Damages -----  | 132 |
| 11.7.2 Liquidated Damages -----   | 133 |
| 11.7.3 Assessment of Liquidated Damages-----  | 133 |
| ARTICLE 12: CHANGES-----  | 133 |
| 12.1 CHANGE INSTRUMENTS-----  | 133 |
| 12.1.1 Amendment only by Written Modification -----                                 | 133 |
| 12.1.2 Change Instruments -----   | 133 |
| 12.1.3 Change Proposals -----   | 133 |
| 12.1.4 Preparation and Submission of Change Orders<br>and Contract Amendments-----  | 133 |
| 12.1.5 Performance of Changes-----  | 133 |
| 12.2 CHANGE ORDERS-----   | 133 |
| 12.2.1 Utilization -----  | 133 |
| 12.2.2 Adjustments in Amount Payable to Contractor ----                             | 133 |
| 12.2.3 Adjustments in Progress Schedule-----  | 134 |
| 12.2.4 Absence of Proposed Adjustments -----  | 134 |
| 12.2.5 Action Upon Receipt-----   | 134 |
| 12.3 FIELD ORDERS -----   | 134 |
| 12.3.1 Utilization -----  | 134 |
| 12.3.2 Adjustments in Amount Payable to Contractor ----                             | 135 |
| 12.3.3 Adjustments in Progress Schedule-----  | 135 |
| 12.3.4 Absence of Proposed Adjustments -----  | 135 |
| 12.3.5 Action Upon Receipt-----   | 136 |
| 12.4 DIFFERING CONDITIONS (SITE AND STRUCTURAL)-----                                | 136 |
| 12.4.1 Differing Site Conditions -----  | 136 |
| 12.4.2 Differing Structural Conditions in Remodeling<br>or Renovation Contract----- | 136 |
| 12.4.3 Investigation and Determination by<br>Architect/Engineer -----               | 136 |
| 12.4.4 Disputes Over Differing Structural Conditions ----                           | 137 |
| 12.5 CONSTRUCTIVE CHANGES AND DISPUTED<br>ADJUSTMENTS -----                         | 137 |
| 12.5.1 Notice to Owner and Architect/Engineer -----                                 | 137 |
| 12.5.2 Disputed Adjustments-----  | 137 |
| 12.6 SUBSTITUTIONS AND OR-EQUAL ITEMS-----  | 137 |

|  |            |
|--|------------|
| 12.6.1 Allowance of Substitutions and Or-Equal Items ---                         | 137        |
| 12.6.2 Or-Equal Items -----  | 137        |
| 12.6.3 Substitutions -----   | 138        |
| 12.6.4 Representations by Contractor -----                                       | 138        |
| 12.6.5 Costs Borne by Contractor -----   | 138        |
| 12.6.6 Timeliness -----  | 138        |
| 12.6.7 Improper Substitutions -----  | 138        |
| <b>ARTICLE 13: PAYMENTS -----</b>  | <b>139</b> |
| <b>13.1 SCHEDULE OF VALUES -----</b>   | <b>139</b> |
| 13.1.1 Submission -----  | 139        |
| 13.1.2 Form and Contents of Schedule of Values -----                             | 139        |
| 13.1.3 Review and Approval -----   | 139        |
| <b>13.2 APPLICATIONS FOR PAYMENT -----</b>                                       | <b>139</b> |
| 13.2.1 Initial Review and Submission -----                                       | 139        |
| 13.2.2 Form and Contents of Application -----                                    | 139        |
| 13.2.3 Inclusion of Stored Materials -----                                       | 139        |
| 13.2.4 Exclusion of Amounts Not Payable to<br>Subcontractors and Suppliers ----- | 139        |
| 13.2.5 Contract Retainage -----  | 139        |
| 13.2.6 Passage of Clear Title -----  | 140        |
| 13.2.7 Contractor's Certification -----  | 140        |
| 13.2.8 Application of Payments for Field Orders -----                            | 140        |
| <b>13.3 CERTIFICATES FOR PAYMENT -----</b>                                       | <b>140</b> |
| 13.3.1 Issuance of Certificate for Payment -----                                 | 140        |
| 13.3.2 Representation in Certificate for Payment -----                           | 140        |
| 13.3.3 Withholding Certification -----   | 141        |
| 13.3.4 Grounds for Withholding Certification -----                               | 141        |
| 13.3.5 Release of Certificate When Grounds Removed ---                           | 141        |
| <b>13.4 PROGRESS PAYMENTS -----</b>  | <b>141</b> |
| 13.4.1 Withholding of Payment by Owner -----                                     | 141        |
| 13.4.2 Payment -----   | 142        |
| 13.4.3 Payment Not Acceptance of Defective Work -----                            | 142        |
| 13.4.4 Payment Contingent on Performance -----                                   | 142        |
| 13.4.5 Waiver of Claims by Contractor -----                                      | 142        |
| <b>ARTICLE 14: SUBSTANTIAL AND FINAL COMPLETION -----</b>                        | <b>142</b> |
| <b>14.1 PARTIAL OCCUPANCY OR USE -----</b>                                       | <b>142</b> |
| 14.1.1 Occupancy by Owner -----  | 142        |
| 14.1.2 Notice by Owner -----   | 142        |
| 14.1.3 Notice by Contractor -----  | 142        |
| 14.1.4 Inspection -----  | 142        |
| 14.1.5 Conditions for Partial Occupancy or Use -----                             | 142        |

|   |            |
|---|------------|
| 14.1.6 Partial Occupancy or Use Not Acceptance of<br>Defective Work -----         | 142        |
| <b>14.2 SUBSTANTIAL COMPLETION -----</b>  | <b>142</b> |
| 14.2.1 Notice and Request for Preliminary Inspection ----                         | 142        |
| 14.2.2 Submittals on Substantial Completion -----                                 | 143        |
| 14.2.3 Substantial Completion Inspection and<br>Correction -----                  | 143        |
| 14.2.4 Reinspection-----  | 143        |
| 14.2.5 Certification of Substantial Completion-----                               | 143        |
| 14.2.6 Execution and Acceptance of Certificate-----                               | 143        |
| 14.2.7 Conditions of Substantial Completion-----                                  | 143        |
| 14.2.8 Commencement of Warranties -----   | 144        |
| 14.2.9 Delivery of Premises and Access to Work -----                              | 144        |
| 14.2.10 Timing of Final Completion -----  | 144        |
| 14.2.11 Broom Clean -----   | 144        |
| <b>14.3 FINAL COMPLETION-----</b>   | <b>144</b> |
| 14.3.1 Notice and Request for Final Inspection-----                               | 144        |
| 14.3.2 Final Inspection and Certificate of<br>Final Completion-----               | 144        |
| 14.3.3 Final Submittals -----   | 144        |
| 14.3.4 USGBC LEED Certification Required for Final<br>Completion-----             | 145        |
| <b>14.4 FINAL ACCEPTANCE AND PAYMENT-----</b>                                     | <b>145</b> |
| 14.4.1 Final Certificate for Payment-----   | 145        |
| 14.4.2 Delay in Final Completion-----   | 145        |
| 14.4.3 Final Payment -----  | 145        |
| 14.4.4 Withholding by Owner from Final Payment-----                               | 146        |
| 14.4.5 Waiver of Claims by Owner-----   | 146        |
| 14.4.6 Waiver of Claims by Contractor-----  | 146        |
| <b>ARTICLE 15: RIGHTS AND REMEDIES -----</b>                                      | <b>146</b> |
| <b>15.1 OWNER’S RIGHTS AND REMEDIES-----</b>                                      | <b>146</b> |
| 15.1.1 Special and Additional Testing and Inspection ----                         | 146        |
| 15.1.2 Rejection of Nonconforming Work-----                                       | 146        |
| 15.1.3 Withholding of Certificates and Withholding of<br>Payments -----           | 146        |
| 15.1.4 Additional Bonds and Insurance -----                                       | 146        |
| 15.1.5 Removal of Superintendent, Personnel,<br>Subcontractors or Suppliers ----- | 146        |
| 15.1.6 Stopping or Suspending the Work-----                                       | 146        |
| 15.1.7 Correction of Defective Work by Owner -----                                | 146        |
| 15.1.8 Cleaning Up-----   | 146        |
| 15.1.9 Owner Takeover -----   | 147        |

|             |   |     |
|-------------|---|-----|
| 15.2        | TERMINATION BY OWNER FOR CONVENIENCE-----                                       | 147 |
| 15.2.1      | Owner's Right To Terminate for Convenience-----                                 | 147 |
| 15.2.2      | Action by Contractor Upon Notice-----   | 147 |
| 15.2.3      | Action by Owner Following Notice-----   | 147 |
| 15.2.4      | Contract Adjustments-----   | 147 |
| 15.2.5      | Obligations to Continue-----  | 148 |
| 15.3        | TERMINATION BY THE OWNER FOR CAUSE-----   | 148 |
| 15.3.1      | Owner's Right to Terminate for Cause-----                                       | 148 |
| 15.3.2      | Grounds for Termination-----  | 148 |
| 15.3.3      | Notice of Termination-----  | 148 |
| 15.3.4      | Action by Contractor and Owner-----   | 149 |
| 15.3.5      | Suspension of Payments-----   | 149 |
| 15.3.6      | Adjustments and Payments-----   | 149 |
| 15.3.7      | Right to Take Other Than Low Bid-----   | 149 |
| 15.3.8      | Termination As If For Convenience-----  | 149 |
| 15.4        | CONTRACTOR'S NO RIGHT TO STOP WORK-----   | 149 |
| ARTICLE 16: | CONTRACT DISPUTES-----  | 149 |
| 16.1        | CLAIM-----  | 149 |
| 16.2        | CONTRACT ADMINISTRATOR'S DECISION ON<br>CONTRACTOR'S CLAIM-----                 | 150 |
| 16.3        | DISPUTE-----  | 150 |
| 16.4        | APPEAL OF THE DIRECTOR'S DECISION<br>(DISPUTE APPEAL)-----                      | 150 |
| 16.5        | INCORPORATION OF THE MONTGOMERY COUNTY<br>CODE AND PROCUREMENT REGULATIONS----- | 150 |
| ARTICLE 17: | INSURANCE AND BONDS-----  | 150 |
| 17.1        | PERFORMANCE AND PAYMENT BONDS-----  | 150 |
| 17.1.1      | Requirement for Bonds-----  | 150 |
| 17.1.2      | Copies to be Furnished to Beneficiaries-----                                    | 150 |
| 17.1.3      | Owner's Right to Require Additional Bonds-----                                  | 151 |
| 17.2        | CONTRACTOR'S LIABILITY INSURANCE-----   | 151 |
| 17.2.1      | Requirement for Insurance-----  | 151 |
| 17.2.2      | Scope of Coverage-----  | 151 |
| 17.2.3      | Additional Insureds-----  | 151 |
| 17.2.4      | Insurance Coverage and Limits of Liability-----                                 | 151 |
| 17.2.5      | Duration of Coverage-----   | 151 |
| 17.2.6      | Notice of Cancellation, Expiration or Non-<br>renewal-----                      | 151 |
| 17.2.7      | Certificates and Policies of Insurance-----                                     | 151 |
| 17.2.8      | Acceptance or Approval by Owner-----  | 152 |

|   |            |
|---|------------|
| <b>17.3 PROPERTY INSURANCE</b>  | <b>152</b> |
| 17.3.1 Owner’s Coverage Limited   | 152        |
| 17.3.2 Builder’s All Risk Coverage to Be Provided by Contractor             | 152        |
| 17.3.3 Policy Form  | 152        |
| 17.3.4 Amount of Coverage   | 152        |
| 17.3.5 Scope of Coverage  | 152        |
| 17.3.6 Work Stored or in Transit  | 152        |
| 17.3.7 Duration of Coverage   | 152        |
| 17.3.8 Notice of Cancellation, Expiration or Non-renewal                    | 152        |
| 17.3.9 Certificates and Policies of Insurance                               | 152        |
| 17.3.10 Absence of Coverage   | 152        |
| <b>17.4 OTHER INSURANCE</b>   | <b>152</b> |
| 17.4.1 Owner’s Liability Insurance  | 153        |
| 17.4.2 Boiler and Machinery Insurance                                       | 153        |
| 17.4.3 Insurance Covering Partial Use or Occupancy                          | 153        |
| 17.4.4 Other Insurance Required by Owner                                    | 153        |
| <b>17.5 GENERAL PROVISIONS</b>  | <b>153</b> |
| 17.5.1 Adjustment of Insured Losses by Owner                                | 153        |
| 17.5.2 Distribution of Proceeds by Owner and Contractor                     | 153        |
| <b>ARTICLE 18: NONDISCRIMINATION IN EMPLOYMENT</b>                          | <b>153</b> |
| <b>ARTICLE 19: STATUTORY REQUIREMENTS</b>                                   | <b>153</b> |
| 19.1 ETHICS REQUIREMENTS/POLITICAL CONTRIBUTIONS                            | 153        |
| 19.2 MINORITY CONTRACTING   | 154        |
| 19.2.1 Policy   | 154        |
| 19.2.2 Applicable Regulations   | 154        |
| 19.2.3 Minority Business Addendum   | 154        |
| 19.3 AMERICAN STEEL   | 154        |
| 19.3.1 American Steel   | 154        |
| 19.4 PREVAILING WAGE  | 154        |
| 19.4.1 State of Maryland  | 154        |
| 19.4.2 Montgomery County  | 156        |
| 19.4.3 Bond   | 156        |
| 19.5 COST AND PRICING DATA  | 156        |
| 19.6 HAZARDOUS AND TOXIC SUBSTANCES   | 156        |
| 19.7 HEALTH INSURANCE PORTABILITY AND ACCOUNTABILITY ACT (HIPAA) COMPLIANCE | 157        |



|  |     |
|--|-----|
| 19.8 IMMIGRATION REFORM AND CONTROL ACT-----                                       | 157 |
| ARTICLE 20: MISCELLANEOUS PROVISIONS-----  | 157 |
| 20.1 MISCELLANEOUS PROVISIONS-----   | 157 |
| 20.1.1 Assignment -----  | 157 |
| 20.1.2 Assignment of Payments -----  | 157 |
| 20.1.3 Audit Provisions-----   | 157 |
| 20.1.4 Extent of Contract -----  | 157 |
| 20.1.5 Governing Law-----  | 157 |
| 20.1.6 Obligations Surviving Termination -----                                     | 157 |
| 20.1.7 Severability of Provisions-----   | 157 |
| 20.1.8 Third Parties -----   | 157 |
| 20.1.9 Venue and Jurisdiction -----  | 157 |
| 20.1.10 Waiver of Breach -----   | 157 |
| 20.1.11 Written Notice-----  | 158 |
| 20.1.12 Intellectual Property Approval And<br>Indemnification – Infringement ----- | 158 |

# ARTICLE 1

## DEFINITIONS AND USE OF TERMS

### 1.1 DEFINED TERMS

**1.1.1 Addendum.** An Addendum is a written or graphic instrument issued prior to the opening of Bids or Proposals, which clarifies, corrects or changes the Solicitation.

**1.1.2 Affiliated Entity.** An Affiliated Entity is (i) any person who is a spouse, parent, natural or adopted descendant, spouse of such descendant, sibling of such person or a trust of which any person named in this clause (i) is the primary income beneficiary; (ii) any person who directly or indirectly owns, controls or holds the power to vote fifty percent (50%) or more of the outstanding voting securities (including partnership interests) of the person in question; (iii) any person fifty percent (50%) or more of whose outstanding securities (including partnership interests) are directly or indirectly owned, controlled by, or held with power to vote by the person in question; (iv) any person directly or indirectly controlling, controlled by, or under direct common control with the person in question; (v) if the person in question is a corporation, any executive officer or director of such person or of any corporation directly or indirectly controlling such person; (vi) if the person in question is a partnership, any general partner of the partnership or any limited partner owning or controlling fifty percent (50%) or more of either the capital or profits interest in such partnership; and (vii) if the person in question is a limited liability company, any managing member of the limited liability company or any member owning or controlling fifty percent (50%) or more of either the capital or profits interest in such limited liability company. As used in this definition, "control" means the possession, directly or indirectly, of the power to direct or cause the direction of the management and policies of a person, whether through the ownership of voting securities, by contract, or otherwise.

**1.1.3 Intentionally Not Used.**

**1.1.4 Allowance.** An Allowance is an estimated monetary amount established in the Contract Documents and included in the Contract Sum for a portion of the Work to be performed by the Contractor.

**1.1.5 Application for Payment.** An Application for Payment is a request from the Contractor for a progress or final payment on the prescribed form and includes all information

required to be submitted with the form to substantiate the Contractor's right to payment. Unless otherwise provided, Applications for Payment must be submitted in the format specified by the Owner.

**1.1.6 Architect, Architect/Engineer, A/E.** The Architect, Architect/Engineer, A/E is a person or an entity identified as such in the Contract Documents.

**1.1.7 Bid.** The Bid is an offer to furnish construction in conformity with the specifications, terms and conditions, and other requirements included in the Invitation for Bids.

.1 The *Base Bid* is the sum stated in the Bid for which the Contractor has offered to perform the Work described in the Bid Documents as the base.

.2 A *Bid Alternate* or *Alternate* is an amount stated in the Contractor's Bid to be added to or deducted from the amount of the Base Bid if the corresponding Change in the Work, as described in the Bid Documents, is accepted by the Owner in the Contract.

**1.1.8 Bid Documents.** The Bid Documents means the Invitation for Bids and all attachments.

**1.1.9 Bid, Performance and Payment Bonds.** The term Bid, Performance and Payment Bonds refers to instruments of security issued in accordance with the requirements set forth in the Bid Documents or the Contract Documents by a surety authorized to do business in the State of Maryland and approved by the Owner.

**1.1.10 Certificate for Payment.** A Certificate for Payment is the original or a copy of the Contractor's Application for Payment, which has been reviewed and recommended by the Architect/Engineer.

**1.1.11 Certificate of Final Completion.** The Certificate of Final Completion is a form the Owner issues to confirm the date of Final Completion.

**1.1.12 Certificate of Insurance.** A Certificate of Insurance is a form acceptable to the Owner, describing and certifying the insurance coverage obtained by the insured Contractor or Subcontractor from an insurer acceptable to the Owner.

**1.1.13 Certificate of Substantial Completion.** The Certificate of Substantial Completion is a form the Owner issues to confirm the Substantial Completion in accordance with Section 14.2.

**1.1.14 Change Order.** A Change Order is a written directive by the Owner to the Contractor directing a change in the Work which is within the general scope of the contract and which may increase or decrease the Contract Time and/or the Contract Sum issued with or without the consent of the Contractor.

**1.1.15 Contract.** The Contract is the written agreement between the Owner and the Contractor, as executed by the parties, covering the Work to be performed and fixing the Contract Time and the Contract Sum. The Contract is comprised of the Contract Documents.

**1.1.16 Contract Administrator** The Contract Administrator is the Owner's representative authorized to oversee administration of the Contract as provided in Section 4.1.

**1.1.17 Contract Amendment.** A Modification to a Contract signed by the Contractor and Director which provides for a change in the Contract provisions, including additional work outside the scope of the original Contract.

**1.1.18 Contract Documents.** The Contract Documents consist of the Contract between Owner and Contractor, Conditions of the Contract (General, Supplementary and other Conditions), Drawings, Specifications, addenda issued prior to execution of the Contract, other documents listed in the Contract, Modifications issued after execution of the Contract Performance and Payment Bonds, Notice to Proceed, mandatory insurance requirements, and Master Schedule and Critical Contract Completion Period. Unless specifically enumerated in the Contract, the Contract Documents do not include other documents such as bidding requirements (advertisement or invitation to bid, Instructions to Bidders, sample forms, the Contractor's bid or portions of addenda relating to bidding requirements). The Contract Documents also include, by reference, the applicable provisions of the Montgomery County Code (2004), as amended, and the Montgomery County Procurement Regulations, as amended, in effect at the time of Contract award.

**1.1.19 Contract Sum.** The Contract Sum is the total amount stated in the Contract which is payable by the Owner to the Contractor for

proper performance of the Work under the Contract Documents. The Contract Sum is subject to adjustment only as provided herein.

**1.1.20 Contract Time.** The Contract Time is the total period of time stated in the Contract between the Date of Commencement and Substantial Completion of the Work. The Contract Time is subject to adjustment only by Change Order as provided herein.

**1.1.21 Contractor.** The Contractor is the person or entity identified as such in the Bid or Proposal and referred to in the Contract executed by the Owner. The Contractor is also the person or entity identified as the principal on the Bid, Performance and Payment Bonds.

**1.1.22 Coordination Drawings.** Drawings prepared by the Contractor showing comprehensive coordination of all Work including but not limited to structural, architectural, vertical transportation, mechanical, plumbing, fire protection and electrical systems.

**1.1.23 Date of Commencement.** The Date of Commencement of the Work is the date established in the Notice to Proceed upon which the Contract Time begins to run; or if no date is established, then it is the date of the Notice to Proceed.

**1.1.24 Date of Substantial Completion.** The Date of Substantial Completion is the date certified by the Architect/Engineer and accepted by the Owner in accordance with Section 14.2 upon which the Work is found to be substantially complete.

**1.1.25 Day.** Unless otherwise specifically modified, the term "day" means a calendar day.

**1.1.26 Defective or Nonconforming Work.** "Defective or nonconforming" is Work that is unsatisfactory, faulty or deficient, in that it:

- .1 Does not conform to the Contract Documents;
- .2 Does not meet the requirements of any inspection, test or approval referred to in the Contract Documents or required by law;
- .3 Is used or not of recent manufacture;
- .4 Contains defects;
- .5 Represents an Or-Equal or Substitution not properly approved by the Owner; or
- .6 Has been damaged prior to Substantial Completion.

**1.1.27 Delay.** The term “delay” refers to any circumstance which has the effect of preventing the Contractor from performing Work, or a portion thereof, which at the time of the delay was on the Critical Path of the most recent CPM Schedule of Record.

- .1 An *excusable delay*, as defined in Subsection 11.5.1 may entitle the Contractor to an adjustment in the Contract Time, but does not entitle the Contractor to any additional compensation.
- .2 A *compensable delay*, as defined in Subsection 11.5.2 may entitle the Contractor to additional compensation and an adjustment in the Contract Time.
- .3 An *unexcused delay*, as defined in Subsection 11.5.3 does not entitle the Contractor to an adjustment in the Contract Time or additional compensation, and may subject the Contractor to claims for damages from the Owner including Liquidated Damages.

**1.1.28 Department.** The Department means the County’s using department..

**1.1.29 Director.** The Director means the Director, Office of Procurement.

**1.1.30 Drawings.** The Drawings are the graphic and pictorial portions of the Contract Documents identified in the executed Contract, generally including plans, elevations, sections, details, schedules and diagrams, and any revisions, supplements or clarifications thereto issued after execution of the Contract.

**1.1.31 Field Order.** A Field Order is a written instruction issued by the Owner to the Contractor directing a change in the Work when unforeseen and unanticipated conditions arise which require immediate action to mitigate costs or avoid delays. It may provide for additional compensation to be paid to the Contractor (outside of the Contract Sum under a separate encumbrance), but does not change the Contract Time or Contract Sum. A Field Order may also be issued directing the Contractor’s performance of disputed work.

**1.1.32 Final Completion.** Final Completion is the stage in the progress of the Work, as confirmed by the Owner’s acceptance of the Architect/Engineer’s Certificate of Final Completion in accordance with Article 14, when

all of the Work, including all Punch List work, is complete in accordance with the Contract Documents.

**1.1.33 Geotechnical Studies.** Geotechnical Studies refers to those reports of explorations and tests of subsurface conditions at or contiguous to the Site, which have been prepared for the use of the Architect/Engineer and/or Owner in designing the project. Their accuracy or completeness is limited to the very narrow parameters of locations, timing and depth of the borings, pits and other analyses. As such, they are not intended to, and do not, provide a comprehensive representation of subsurface conditions. The Geotechnical Studies have been made part of the Contract Documents for the limited purpose of design of the Work .The Geotechnical Studies shall not be relied upon by the Contractor for any means or methods of construction. Contractors and Offerors may make their own investigation of existing subsurface conditions. For Contract Modification purposes, the Geotechnical Studies establish a baseline for expected subsurface conditions. The Contractor must show a material difference between the Geotechnical Studies and actual subsurface conditions to justify a Contract Modification.

**1.1.34 Hazardous Materials.** Hazardous Materials means (a) any “hazardous waste” as defined by the Resource Conservation and Recovery Act of 1976 (42 U.S.C. §6901 et seq.), as amended from time to time, and regulations promulgated thereunder; (b) any “hazardous substance” as defined by the Comprehensive Environmental Response, Compensation and Liability Act of 1980 (42 U.S.C. Section 9601 et seq.), as amended from time to time, and regulations promulgated thereunder; (c) any “oil, petroleum products, and their by products” as defined by Md. Code Ann., Envir., §4-401(g) (1996 Repl.Vol.), as amended from time to time, and regulations promulgated thereunder; (d) any “controlled hazardous substance” or “hazardous substance” as defined by Md. Code Ann., Envir., §7-201 (1996 Repl. Vol.), as amended from time to time, and regulations promulgated thereunder; (e) any “infectious waste” as defined by the Md. Code Ann., Envir., §. 9-227 (1996 Repl. Vol.), as amended from time to time and regulations promulgated thereunder; (f) any substance the presence of which on the Project site is prohibited, regulated, or restricted by applicable Laws or Regulations similar to those set forth in this definition; and/or (g) any other substance which by applicable Law or

Regulation requires special handling in its Generation because of its effect or potential effect on the environment. The term "Generation" means the usage, collection, generation, storage, transportation, treatment, or disposition.

**1.1.35 Instructions to Bidders or Offerors.**

The Instructions to bidders or Offerors are issued in conjunction with the Invitation for Bids or Request for Proposals, and set forth some of the requirements applicable to the preparation, submission, opening and consideration of Bids or Proposals and accompanying submittals, and the award and execution of the Contract.

**1.1.36 Invitation for Bids.** Invitation for Bids or IFB is a Solicitation to prospective Offerors, the response to which is analyzed in accordance with selection criteria set forth in the Solicitation for the purpose of ranking the Bids received.

**1.1.37 Laws and Regulations.** The term "laws and regulations" includes the applicable laws, rules, regulations, ordinances, codes and orders of any and all governmental bodies, agencies, authorities and courts having jurisdiction over the Contract or the Project.

**1.1.38 Liquidated Damages.** The term "liquidated damages" refers to the amount payable by the Contractor to the Owner for each day of unexcused delay in achieving Substantial Completion of the Work. The amount of liquidated damages is initially set forth in the Bid Documents and is stated in the executed Contract.

**1.1.39 Modification.** A Modification is (i) a Contract Amendment, (ii) a Change Order, or (iii) a Field Order.

**1.1.40 Notice to Proceed.** A Notice to Proceed is one or more written notice(s) given by the Owner to the Contractor fixing the date on which the Contract Time or a designated portion thereof will commence to run and by which the Contractor must start to perform the Work or a designated portion thereof as stated in the Notice to Proceed.

**1.1.41 Offer.** The term Offer refers to either a Bid or Proposal as the case may be.

**1.1.42 Offeror.** The term Offeror refers to the person or entity making an Offer.

**1.1.43 Or-Equal Item.** The term Or-Equal Item refers to an item of material or equipment proposed by the Contractor that is allowed by the Contract Documents and, in the Owner's sole discretion, is functionally equal to an item

specified or described in the Contract Documents. "Functionally equal" means that the item is sufficiently similar to that specified or described that, in the opinion of the Owner, the item meets or exceeds the physical characteristics, performance ratings, durability, serviceability, appearance and other relevant characteristics of the item specified or described in the Contract Documents, and that no change in design or related Work will be required. See Section 12.6.

**1.1.44 Owner.** The Owner is Montgomery County, Maryland. Unless noted otherwise, including specifically the exceptions outlined in Section 4.1, the authority of the Owner is granted to the Contract Administrator or such person as is expressly designated in writing by the Director as having such authority. For the purposes of ordering extra work by a Field Order, the Owner is defined as the Contract Administrator. Only the Director has the authority to execute a Change Order or Contract Amendment.

**1.1.45 Product Data.** Product Data generally consist of preprinted illustrations, standard schedules, performance charts, instructions, brochures, diagrams and other information prepared by a supplier and provided by the Contractor to illustrate materials or equipment to be incorporated in the Work.

**1.1.46 Progress Schedule.** The Progress Schedule is a schedule prepared by the Contractor, in accordance with the requirements of the Contract Documents and which is approved by the Owner, indicating the starting and completion dates for each portion of the Work, including any interim contractually required completion dates. The Contractor must prepare computer generated schedules in accordance with the Contract Documents.

**1.1.47 Project.** The Project is the total capital project administered by the Department, of which the Work performed under the Contract may be the whole or a part in conjunction with construction or other operations by the Owner or Separate Contractors.

**1.1.48 Project Manager.** The term Project Manager refers to the person designated as such by the Contractor having authority to act on behalf of the contractor with respect to all aspects of the Project and to whom the Superintendent reports.

**1.1.49 Project Manual.** The Project Manual is the volume assembled for the Project which

generally includes the Specifications, the Bid or Proposal Documents, the Contract, any Geotechnical Studies, and other Project related documents.

**1.1.50 Proposal.** The Proposal is the Contractor's complete and properly signed response to a Request for Proposal.

**1.1.51 Proposal Documents.** The Proposal Documents means the Request for Proposal (RFP) and all addenda.

**1.1.52 Punch List.** The Punch List is the list initially prepared by the Contractor for review, supplementation and approval by the Owner and the Architect/Engineer at the time of Substantial Completion of all or a portion of the Work, identifying items that are required to be completed or corrected by the Contractor as part of Final Completion (as set forth in Article 14) of the Work.

**1.1.53 Record Documents.** The term Record Documents refers to record copies, maintained at the Site by the Contractor for the Owner, of the Drawings, Specifications, Addenda, Change Orders, Field Orders and other Modifications, the most recently approved Progress Schedule and Superintendent daily records, all in good order and marked currently to record all changes and selections made during construction and their approval, and record copies of approved Shop Drawings, Product Data, Samples and similar required Submittals.

**1.1.54 Referenced Standards.** The term Referenced Standards includes standards, standard details, specifications, manuals, regulations or codes of any technical society, organization or association, or of any governmental or quasi-governmental authority referred to in the Contract Documents to describe the nature or quality of any of the Work, whether such reference be specific or by implication, and means the latest standard, standard detail, specification, manual, regulation or code in effect at the time of Bid or Proposal opening, except as may be otherwise specifically stated in the Contract Documents.

**1.1.55 Request for Proposal.** Request for Proposal or RFP is a solicitation to prospective Offerors, the response to which is analyzed in accordance with selection criteria set forth in the solicitation for the purpose of ranking the Proposals received.

**1.1.56 Samples.** Samples are physical examples of products, materials, equipment, assemblies or workmanship to be incorporated

in the Work, and which are intended to establish standards for the completed Work.

**1.1.57 Schedule of Submittals.** The Schedule of Submittals is a listing and time schedule of Submittals prepared by the Contractor for review and approval by the Owner and the Architect/Engineer as provided in Subsection 11.2.5.

**1.1.58 Schedule of Values.** The Schedule of Values is a breakdown of the Contract Sum by Construction Specification Institute (CSI) divisions prepared by the Contractor for review and approval by the Owner and the Architect/Engineer as provided in Section 13.1.

**1.1.59 Separate Contractor.** The term Separate Contractor refers to a person or entity with which the Owner has contracted to construct other portions of the Project or perform other operations at the Site.

**1.1.60 Shop Drawings.** Shop Drawings generally consist of those drawings, diagrams, schedules and other data specially prepared for the Work by the Contractor or a Subcontractor, Sub-subcontractor, manufacturer, Supplier or distributor detailing the fabrication or assembly of some portion of the Work, copies of which are submitted by the Contractor to the A/E for approval to indicate the details of execution of that portion of the Work. The cost of preparing Shop Drawings, including Coordination Drawings, is the responsibility of the Contractor, which is included in the Contract Sum and for which the Contractor will not be paid any additional compensation. The Contractor must also, at no additional compensation, provide calculations to the A/E for approval for design/engineering portions of the Work. The submission and/or approval of Shop Drawings cannot change the Contract Documents.

**1.1.61 Site.** The term Site refers to that portion of the property on which the Work is to be performed or which has been otherwise set aside for use by the Contractor.

**1.1.62 Site Survey.** This term includes, but is not limited to site plans, topographic surveys and property surveys and refers to those drawings of physical conditions in or relating to existing surface or subsurface structures at or contiguous to the Site which have been utilized by the Architect/Engineer or Owner in preparing the Contract Documents or which have been provided by the Owner for the Contractor's information in evaluating Site conditions.



**1.1.63 Solicitation.** The term Solicitation means an Invitation for Bid or a Request for Proposal and all addenda.

**1.1.64 Specifications.** The Specifications are that portion of the Contract Documents, generally included in and identified as such in the Project Manual, setting forth the written requirements for materials, equipment, construction systems, standards and workmanship for the Work, and performance of related services.

**1.1.65 Subcontractor.** A Subcontractor is a person or entity who has a direct contract with the Contractor to perform a portion of the Work, and includes any Supplier who performs Work such as installation of materials and equipment. The term "Subcontractor" does not include a Separate Contractor or any subcontractors of a Separate Contractor.

**1.1.66 Submittals.** The term Submittals refers to all items relating to the performance of the Work which are required to be submitted by the Contractor to the Owner and/or the Architect/Engineer for review, acceptance or approval. Submittals include, but are not limited to, items such as the Schedule of Values, Progress Schedule, Schedule of Submittals, lists of Subcontractors and Suppliers, insurance certificates, Shop Drawings, Product Data, Samples, requests for substitutions or use of Or-Equal Items, Record Documents, Warranties and operating manuals, and similar items. As used herein, the term "Submittal" does not include change proposals submitted by the Contractor, the Contractor's Applications for Payment and supporting data, Disputes or Claims.

**1.1.67 Substantial Completion.** Substantial Completion is the stage in the progress of the Work, as confirmed by the Owner's acceptance of the Architect/Engineer's Certificate of Substantial Completion in accordance with Article 14, when the Work or designated portion thereof is sufficiently complete in accordance with the Contract Documents (i) so the Owner can occupy or utilize the entire Work or designated portion thereof for its intended use and (ii) that the completion or correction of any Punch List items can be accomplished within a period of 30 days.

**1.1.68 Substitution.** The terms Substitution and Substitute Item refer to an item of material or equipment proposed and certified by the Contractor as substantially equivalent to an item specified or described in the Contract

Documents by using the name of a proprietary item, a particular manufacturer or a particular Supplier, and the substitution of the item is not expressly prohibited, and the proposed replacement, in the Owner's sole discretion, is functionally, technically and aesthetically equal to the item specified or described.

**1.1.69 Sub-subcontractor.** A Sub-subcontractor is a person or entity who has a direct or indirect contract at any tier with a Subcontractor to perform a portion of the Work.

**1.1.70 Superintendent.** The term Superintendent refers to the person designated as the Contractor's representative at the Site with overall responsibility for direction and execution of the Work, and unless otherwise designated by the Contractor, for the protection of persons and property at the Site and compliance with all applicable Laws and Regulations.

**1.1.71 Supplemental Conditions.** The Supplemental Conditions are that part of the Contract Documents, designated as such, which amend or supplement these General Conditions.

**1.1.72 Supplier.** The term Supplier refers to any manufacturer, fabricator, supplier, distributor, materialman or vendor furnishing materials or equipment to be incorporated in the Work by the Contractor or any Subcontractor or Sub-subcontractor.

**1.1.73 Surety.** The term Surety refers to any corporation, person or entity, authorized to do business in the State of Maryland, which has issued a Bid Bond, Performance Bond, a Labor and Material Payment Bond, or similar security on the Contractor's behalf, in accordance with the requirements of the Contract Documents.

**1.1.74 Taxes.** The term Taxes includes all applicable federal, State, and local taxes and duties, including sales, consumer, use and similar taxes for the Work or portions thereof provided by the Contractor and all social security, unemployment, and similar employment taxes, withholding and contributions for employees, which are legally enacted before the opening of Bids or Proposals and effective at any time during the performance of the Work. **All Taxes applicable to the performance of the Work are payable by the Contractor and included in the Contract Sum. The Contractor will not be paid any additional compensation for payment of Taxes except for Taxes which are legally enacted after the opening of Bids or Proposals.**



### **1.1.75 Intentionally Not Used.**

**1.1.76 Unit Prices.** The term Unit Prices refers to the rates stated in the Proposal or Bid Documents at which change work (additive or deductive work) is to be performed by the Contractor or deducted from the Contract Sum. Unit Prices include all direct labor and materials costs, payroll burden, relocation of stockpiled materials as necessary, indirect job costs such as insurance, bonds, coordination, engineering, permits, cleanup, tools, profit, and overhead (which includes office overhead and site-specific overhead and general conditions) and all other costs necessary to complete the Work.

**1.1.77 Warranties and Guarantees.** The terms Warranties and Guarantees generally refer to written instruments, certificates, acknowledgments or similar documents required by the Contract Documents (other than the Contractor's general warranty) evidencing specific obligations and undertakings by the Contractor, Subcontractors, Sub-subcontractors and Suppliers, to correct, repair or replace a portion of the Work covered by such Warranty or Guarantee.

**1.1.78 Work.** The Work means the construction and services required by the Contract Documents, whether completed or partially completed, including all labor, materials, equipment and services provided or to be provided by the Contractor for incorporation into the completed construction required by the Contract Documents. The Work may constitute the whole or a part of the Project.

## **1.2 USE OF TERMS**

**1.2.1 Singular and Plural.** The Owner, Architect/Engineer, Contractor, Subcontractor, Sub-subcontractor, Supplier, Separate Contractor, Surety, insurer and others are referred to throughout the Contract Documents as if singular in number. In the event that more than one person or entity occupies the position referred to and unless otherwise indicated, the term is interpreted to include all such persons or entities.

**1.2.2 Technical Terms and Trade Usage.** Terms in the Contract Documents which have well-known technical or construction industry meanings and are not otherwise defined are used in accordance with such recognized meanings unless the context clearly indicates otherwise.

**1.2.3 Titles and Headings.** The titles and headings of the various sections and

subsections of these General Conditions and other Contract Documents are intended only as a matter of reference and convenience and in no way define, limit, or prescribe the scope or intent of the Contract Documents.

## **ARTICLE 2**

---

### **THE CONTRACT**

#### **2.1 CONTRACT**

**2.1.1 Changes.** The Contract may be changed only by a Modification.

**2.1.2 Documents Excluded from the Contract.** The Contract Documents do not include documents issued or provided to the Contractor for the information of the Contractor or for reference purposes and which are not specifically incorporated in the Contract Documents.

#### **2.2 ORGANIZATION AND INTENT**

**2.2.1 Contract Documents Complementary.** The Contract Documents are complementary, and what is required by one is as binding as if required by all. Anything mentioned in the Specifications and not shown on the Drawings, or shown on the Drawings and not mentioned in the Specifications, are of like effect as if shown or mentioned in both.

**2.2.2 Intent to Require Completed Project.** The intent of the Contract Documents is to require that the Contractor provide all materials and labor, including tools, equipment and supervision, necessary for the proper execution and completion of the Work

**2.2.3 Work Required if Reasonably Inferable.** Performance by the Contractor is required to the extent consistent with the Contract Documents and reasonably inferable from them as being necessary to produce the intended results. Where no explicit quality or standards for materials or workmanship are established for the Work, the Work is to be of good quality and consistent with the quality of surrounding Work which conforms to the requirements of the Contract Documents and to the standards for construction of the Project generally.

**2.2.4 Organization of Drawings and Specifications.** Organization of the Drawings around professional disciplines such as civil, architectural, structural, plumbing, mechanical and electrical, and of the Specifications into divisions, sections and articles, does not control the Contractor in dividing the Work among Subcontractors or in establishing the extent of

Work to be performed by any trade or excuse the Contractor of its obligation to properly allocate and provide for the performance of all Work under the Contract.

## **2.3 REFERENCED STANDARDS**

**2.3.1 Standards Incorporated.** All Referenced Standards are incorporated into the Contract as fully as if printed and bound with the Specifications, but only to the limited extent that such standards are applicable to the Work.

**2.3.2 Availability of Referenced Standards.** The Contractor is responsible for obtaining and having available at the Site a copy of each Referenced Standard insofar as it is applicable to the Work.

**2.3.3 Precedence of Contract Documents Over Referenced Standards.** No provision of a Referenced Standard is effective to change (i) the procedures established in the Contract Documents or by any applicable laws or regulations, or (ii) the duties and responsibilities of the Owner, Architect/Engineer or Contractor from those set forth in the Contract Documents; nor is any provision of a Referenced Standard effective to assign to the Owner or the Architect/Engineer any duty or authority to supervise or direct the furnishing or performance of the Work or any duty or authority to undertake responsibility inconsistent with the provisions of Article 4 or any other provision of the Contract Documents.

## **2.4 OWNERSHIP AND USE OF DOCUMENTS**

**2.4.1 Copies Furnished.** Unless otherwise provided in the Contract Documents, the Owner will furnish one (1) set of Drawings and the Project Manual free of charge to the Contractor. The Owner will make such additional copies of Drawings and Project Manuals as are reasonably necessary for execution of the Work available to the Contractor at a reasonable cost.

**2.4.2 Ownership of Documents.** The Drawings, Project Manuals and other documents furnished to the Contractor are the Owner's property.

**2.4.3 Copyright and Other Reserved Rights.** The Contractor may not own or claim a copyright in the Drawings, Project Manuals and other documents furnished.

**2.4.4 Use and Reproduction of Documents.** The Drawings, Project Manuals and other documents, including copies furnished to the Contractor, are for use solely with respect to this

Project. They are not to be used by the Contractor on other projects or for additions to this Project outside the scope of the Work without the specific written consent of the Owner, the Architect/Engineer and any of their consultants whose authorship or copyright is indicated thereon and Contractor must include a similar provision in all contracts with its Subcontractors and Suppliers. The Contractor is granted a limited license to use and reproduce applicable portions of the Drawings, Project Manuals and other documents furnished to them appropriate to and for use in the execution of their Work under the Contract Documents, including submittals or distributions to meet regulatory requirements. Submittal or distribution to meet regulatory requirements or for other authorized purposes in connection with this Project is not to be construed as publication in derogation of the Owner's, the Architect/Engineer's, or any of their consultants' copyright or other reserved rights. All copies made under this license must bear the same copyright notice, if any, as is shown on the cover page or on each of the Drawings, Project Manuals and other documents that are reproduced.

**2.4.5 Record Documents.** The Contractor must maintain at the Site for the Owner one set of Record Documents. These must be available to the Owner and the Architect/Engineer for their reference during the progress of the Work. The record drawings and any other Record Documents indicating changes or selections made during construction must be delivered to the Architect/Engineer for submittal to the Owner upon completion of the Work and before final payment becomes due.

**2.4.6 Return of Documents.** All copies of Drawings, Project Manuals and other documents furnished to the Contractor, must be suitably accounted for to the Owner, on request, upon completion of the Work. At the Owner's request, all copies not reasonably required for the Contractor's, Subcontractors' or Sub-subcontractors' records must be returned to the Owner.

## **ARTICLE 3**

### **THE OWNER**

#### **3.1 OWNER'S REPRESENTATIVES**

**3.1.1 Designated Representatives.** The Department carries out the Owner's responsibilities. Unless noted otherwise, including specifically the exceptions outlined in Section 4.1, the authority of the Owner is

granted to the Contract Administrator or such person as is expressly designated in writing by the Director as having such authority. For the purposes of ordering extra work by a Field Order, the Owner is defined as the Contract Administrator or such person as is designated in writing by the Director. Only the Director has the authority to execute a Change Order or Contract Amendment.

**3.1.2 Representative of Legal Owner.** In the event that the Owner is acting for the benefit of another private, nonprofit or governmental entity which is or will become the legal owner of the Project, such legal owner (i) will be identified in the Contract Documents, (ii) will be considered a beneficiary of this Contract, and (iii) will be entitled to enforce all rights and remedies of the Owner hereunder. Unless otherwise provided, however, **the Owner has assumed all responsibility for the performance of the Owner's obligations under this Contract, and nothing herein is to be construed to create any obligation of such legal owner to the Contractor or to provide the Contractor any rights or remedies against such legal owner.**

### **3.2 PROJECT INFORMATION**

**3.2.1 Site Surveys.** The Owner may furnish surveys identifying the boundaries of the Site, the location of existing structures and restrictions of record such as easements and rights of way. The Owner may also furnish information with respect to topographical features and utilities of which the Owner is aware. It is the Contractor's responsibility to determine and verify all information provided by Owner including, but not limited to, grades and elevations. Notwithstanding the foregoing, the Contractor is entitled to rely on information provided by the Owner in arriving at its Contract Sum, and to the extent existing conditions are inconsistent with those shown on information provided by the Owner, the provisions of Section 12.4 shall govern.

It is the Contractor's responsibility to verify the existence and locations of utilities with the appropriate agencies and utility companies.

**3.2.2 Site and Physical Data.** Any Geotechnical Studies or other subsurface information including boring logs, soils and other reports, provided by the Owner to the Contractor.

**3.2.3 Reliance by Contractor.** The Contractor may not rely upon surface or Site and

physical data with respect to the completeness of any reports and drawings for the Contractor's purposes, including, but not limited to, any aspects of the means, methods, techniques, sequences and procedures of construction to be employed by the Contractor or any of the Contractor's safety precautions and programs.

**3.2.4** For Contract Modification purposes, the Geotechnical Studies establish a baseline for expected subsurface conditions. The Contractor must show a material difference between the Geotechnical Studies and actual subsurface conditions to justify a Contract Modification.

### **3.3 OWNER RESPONSIBILITIES**

**3.3.1 Access to Site.** The Owner will furnish the Project Site as indicated in the Contract Documents, and such other lands which are designated in the Contract Documents, if any, for the use of the Contractor. The Contractor is responsible for obtaining any additional rights of way, approvals or easements for access to the Site and/or performance of the Contract resulting from the Contractor's use, means and methods. The Owner may identify in the Contract Documents encumbrances or restrictions not of general application but specifically related to use of the Site which are not of public record. If so identified in the Contract Documents, the Contractor must comply with them in performing the Work. Permanent easements for the completed facility or for changes in existing facilities will be obtained and paid for by the Owner, unless otherwise provided in the Contract Documents.

**3.3.2 Permits and Fees.** Unless otherwise indicated in the Contract Documents, the Owner will be responsible for securing and paying for (i) the building permit (provided that if the Contractor in any way modifies the building permits to phase the Work, then any additional cost resulting will be the responsibility of the Contractor), (ii) fees and surcharges for front footage, (iii) fees and surcharges for water, sewer and gas work and (iv) fees and permits for construction in the County and/or State road rights-of-way. **The Contractor will be responsible for obtaining and paying the costs of all other permits, fees, licenses, bonds and governmental approvals, except as otherwise indicated in the Contract Documents.**

## **ARTICLE 4**

### **ADMINISTRATION OF THE CONTRACT**

#### **4.1 CONTRACT ADMINISTRATION**

**4.1.1 Administration by Owner.** The Contract is administered by the Contract Administrator, the identity of whom is set forth in Article 10 of the Contract. The Contract Administrator is authorized to administer the Contract commencing on the date that the Contract is signed by the Contracting Officer and terminating on the date the Contract is completed or terminated. The Contract Administrator's authority is limited as follows:

- .1 Provide direction to the Contractor to ensure satisfactory and complete performance, including issuance of Field Orders;
- .2 Monitor and inspect Contractor performance to ensure acceptable timeliness and quality;
- .3 Maintain necessary documentation and records regarding Contractor performance and other pertinent matters;
- .4 Determine acceptance or rejection of Contractor's performance;
- .5 Provide Owner determinations in response to Contractor's requests for an increase in the Contract Time and/or an increase in the Contract Sum in accordance with Articles 11 and 12;
- .6 Approve or reject invoices for payment;
- .7 Furnish necessary reports to the Director;
- .8 Furnish notice of Contractor performance failures to the Director and to the Office of the County Attorney, as appropriate; and
- .9 Recommend Contract Modifications or terminations for default or convenience to the Director.

**4.1.2 Contract Administrator Limitations of Authority.** The authority of the Contract Administrator is limited to the functions set forth above. In particular, the Contract Administrator is NOT authorized to make determinations (as opposed to recommendations) that:

- .1 Alter or modify Contracts;

- .2 Terminate or cancel Contracts;
- .3 Approve, as opposed to recommend, Change Orders or Contract Amendments; or
- .4 Waive the Owner's Contract rights.

Unless the Director changes this delegation of authority, in writing, no other person is authorized to perform the functions of the Contract Administrator for this particular Construction Contract between Owner and Contractor.

**4.1.3 Owner's Representatives.** The Contract Administrator may further delegate authority and responsibility for performance of the Owner's administration of the Contract to designated individuals. For the purposes of ordering extra work by Field Order, the Owner is defined as the Contract Administrator.

#### **4.2 CONSTRUCTION ADMINISTRATION**

**4.2.1 Performance of Construction Administration.** Unless otherwise provided in the Contract Documents, ongoing administration of construction as provided in the Contract Documents will be performed by the Contract Administrator with the assistance of the Owner's Project Manager(s), Construction Representative(s), or others as designated by the Contract Administrator, under the overall direction of the Contract Administrator.

**4.2.2 Status of Architect/Engineer.** The Architect/Engineer is not an agent of the Owner, but will assist the Owner in the administration of the Contract and the Work, as described in the Contract Documents, and will be the point of contact for purposes of communication (i) during construction, (ii) until final payment is due, and (iii) with the Owner's concurrence, from time to time during the warranty period described in Section 10.2.

**4.2.3 Owner's Project Manager Limitations of Authority.** The Owner's Project Manager, Construction Representatives and others as designated by the Contract Administrator and the Architect/Engineer will have authority to act on behalf of the Owner only to the extent provided in the Contract Documents, unless otherwise modified by written instrument in accordance with other provisions of the Contract.

**4.2.4 Communications.** Except as otherwise provided in the Contract Documents, the Contractor must communicate through the Architect/Engineer. Communications by and



with (i) the Architect/Engineer's consultants must be through the Architect/Engineer, (ii) Subcontractors, Suppliers and Contractor's consultants must be through the Contractor, and (iii) Separate Contractors and Owner's consultants must be through the Owner.

**4.2.5 Change in Architect/Engineer's Duties.** The Owner may make changes in the duties, responsibilities and limitations of authority of the Architect/Engineer as set forth in the Contract Documents, and will provide written notice of any significant changes to the Contractor. However, no such change will provide the basis for any Claim for a change in the Contract Time or an increase in the Contract Sum.

**4.2.6 Change of Architect/Engineer.** In case of termination of employment of the Architect/Engineer by the Owner, the Owner will appoint a replacement Architect/Engineer whose status under and responsibilities as set forth in the Contract Documents, unless otherwise indicated in a notice of appointment to the Contractor, will be that of the former Architect/Engineer.

**4.2.7 Timeliness of Construction Administration Services.** The Owner and the Architect/Engineer will endeavor to provide approvals, information or services under their control with reasonable promptness to avoid unreasonable delay in the orderly progress of the Work, but the Owner will not be responsible for any delay where the Contractor has not provided reasonable prior notice in writing to the Owner of the time within which such approval, information or services will be required in order to avoid such delay.

### **4.3 ADMINISTRATION OF CONSTRUCTION**

**4.3.1 Interpretation and Clarification of Drawings and Specifications.** The Architect/Engineer, with the approval of the Owner, may issue interpretations and clarifications of the Drawings and Specifications, in graphic or written form as appropriate, on written request of either the Owner or Contractor (Requests for Information (RFIs)), or when otherwise deemed advisable by the Architect/Engineer (Architect's Supplemental Instructions (ASIs)). The Architect/Engineer's response to requests from the Owner or Contractor for interpretations or clarifications (RFIs) will be made within fifteen (15) days of receipt of the written request. Any response is presumed to be a clarification of the Contract

Documents reasonably inferable from them and will not form the basis for any Claim by either party for a change in the Contract Time or the Contract Sum. **If the Contractor contends that the response constitutes a change in the Work, the Contractor must obtain written direction from the Contract Administrator before proceeding with the Work as set forth in Subsection 4.3.12 titled Changes in the Work, and it must file a Claim for an increase in the Contract Time and/or an increase in the Contract Sum in accordance with Article 11 and/or Article 12 or the Contractor will be conclusively deemed to have waived any Claim for an increase in the Contract Time or an increase in the Contract Sum based on the interpretation or instruction contained in any RFI or ASI, or otherwise.**

**4.3.2 Standard of Interpretation.** Interpretations and clarifications by the Architect/Engineer will be consistent with the intent of, and reasonably inferable from, the Contract Documents. When making such interpretations and clarifications, the Architect/Engineer will endeavor to secure faithful performance by both Owner and Contractor, will not show partiality to either and will not be liable to the Contractor for results of interpretations or clarifications issued in good faith.

**4.3.3 Interpretations and Decisions by Owner.** The Owner will provide written interpretations and decisions concerning Contract terms and conditions within a reasonable time after written request is made by the Contractor or as otherwise required during the course of the Project. Any interpretation or decision is presumed to be a clarification of the Contract terms and conditions reasonably inferable from them and may not form the basis for any Claim by the Contractor for a change in the Contract Time or the Contract Sum. **If the Contractor contends that the interpretation or decision constitutes a change in the Work, the Contractor must file a Claim for an increase in the Contract Time and/or an increase in the Contract Sum in accordance with Article 11 and/or Article 12 or the Contractor will be conclusively deemed to have waived any Claim for an increase in the Contract Time or an increase in the Contract Sum based on the interpretation or decision.**

**4.3.4 Acceptability of Superintendent and Key Personnel.** The Contractor will be advised in writing if the Superintendent or other

supervisory personnel prove unsatisfactory to the Owner as provided in Subsection 5.4.2.

**4.3.5 Approval of Subcontractors and Suppliers.** The Contractor will be advised in writing if the Owner has reasonable objection to, and rejects, any proposed Subcontractor or Supplier subject to review by the Owner, as provided in Subsection 6.1.2.

**4.3.6 Approval of Submittals.** The Architect/Engineer and the Owner, as appropriate, will review the Contractor's Submittals and take appropriate action thereon, as required for each type of Submittal. Review and approval of Shop Drawings, Product Data Samples and similar Submittals will be as provided in Section 9.2.

**4.3.7 Site Visits.** The Architect/Engineer and Owner will make Site visits as provided in Subsection 10.3.2.

**4.3.8 Rejection of Work.** The Owner, in consultation with the Architect/Engineer, may reject Work as provided in Subsection 10.6.1.

**4.3.9 Additional Inspection, Testing or Specific Approvals.** The Architect/Engineer has authority to recommend, and the Owner has the authority to require, additional inspection, testing or specific approval of the Work as provided in Subsection 10.5.3.

**4.3.10 Authority to Stop or Suspend Work.** The Owner has the authority to stop or suspend the Work as provided in Subsections 11.4.1 and 11.4.2. The Architect/Engineer does not have authority to stop or suspend the Work on behalf of the Owner unless specific written authority from the Owner to do so is provided in any notice to stop or suspend the Work.

**4.3.11 Review of Applications for Payment.** Based on the Architect/Engineer's observations and evaluations of the Contractor's Applications for Payment and the Work, the Architect/Engineer will certify the amounts due the Contractor and will issue Certificates for Payment in such amounts to the Owner as provided in Section 13.3. The Owner will review and approve such Applications and Certificates and make payment on Owner-approved amounts within the time specified in the Section 13.4.

**4.3.12 Changes in the Work.** The Architect/Engineer may assist the Owner in preparing Change Orders as provided in Section 12.2, Field Orders as provided in Section 12.3 and Contract Amendments. The

Architect/Engineer may, with the Owner's concurrence, authorize minor changes in the Work not involving an increase in the Contract Time or an increase in the Contract Sum.

**Notwithstanding the foregoing or any other provision of the Contract, no additions to or changes in the Work or other extra Work may be performed and no Claim for additional compensation, credit, or increase of time is valid without written authorization by the Contract Administrator and/or Director. Accordingly, no course of conduct or dealings between the parties, no implied acceptance of changes in the Work, and no Claim that the Owner has been unjustly enriched by any change to the Work, can be the basis for any Claim for an increase in the Contract Time or in the Contract Sum.**

**4.3.13 Substantial and Final Completion.** As provided in Article 14, the Architect/Engineer and Owner will conduct inspections to determine the date or dates of Substantial Completion and the date of Final Completion. The Architect/Engineer and Owner will issue Certificates of Substantial and Final Completion and a final Certificate for Payment upon the Architect/Engineer's recommendation and Owner's determination that the Contractor has fully completed the Contract. The Owner may accept partial Substantial Completions as to portions of the Work which have reached Substantial Completion and are available for use by the Owner.

**4.3.14 Recommendations on Payments, Changes, Claims and Disputes.** If the Owner requests, the Architect/Engineer will make recommendations to the Owner concerning payments, changes, Claims and Disputes, and similar matters.

#### **4.4 LIMITATIONS OF OWNER'S AND ARCHITECT/ENGINEER'S RESPONSIBILITIES**

**4.4.1 Charge or Control.** Neither the Owner nor the Architect/Engineer have control over or charge of or are responsible for construction means, methods, techniques, sequences or procedures, or for safety precautions and programs in connection with the Work, since these are solely the Contractor's responsibility as provided in Subsection 5.3.2 and Article 8. Neither the Owner nor the Architect/Engineer will be responsible for the Contractor's failure to carry out the Work in accordance with the Contract Documents.

**4.4.2 Actions not to Relieve Contractor.** No action or failure to act on the part of the Owner or the Architect/Engineer, including but not limited to (i) the acceptance or approval of any Subcontractor, selection, Substitution or Or-Equal Item, Submittal or schedule, (ii) observation or inspection of any of the Work, (iii) the performance of any test or inspection, (iv) assistance in performance of Contractor's Work, or (v) the acceptance or failure to accept any portion of the Work, relieves the Contractor of responsibility for performing the Work in accordance with the Contract Documents.

**4.4.3 Responsibility for Others.** Neither the Owner nor the Architect/Engineer will have control over or charge of and will not be responsible for acts or omissions of the Contractor, Subcontractors, Sub-subcontractors, Suppliers or their agents or employees, or of any other persons performing portions of the Work.

**4.4.4 Inspection, Testing or Approval and Rejection of Work.** The performance of any tests, inspections or approvals required by the Contract Documents does not relieve the Contractor of any of its obligations under the Contract Documents. The Owner's and the Architect/Engineer's authority to require and the Architect/Engineer's authority to recommend additional testing, inspection or approval of Work, and the Owner's and the Architect/Engineer's authority to reject defective or nonconforming Work, does not give rise to any duty or responsibility on the part of either to exercise such authority for the benefit of the Contractor or any other person or entity.

**4.4.5 Stopping or Suspension of Work.** The authority of the Owner to stop the Work under Subsections 11.4.1 or to suspend the Work under Subsection 11.4.2 does not give rise to any duty or responsibility on the part of the Owner to exercise such authority for the benefit of the Contractor or any other person or entity.

**4.4.6 Payments.** The issuance of a Certificate for Payment by the Architect/Engineer under Subsection 13.3.1 or the making of any progress payment or final payment by the Owner under Subsections 13.4.2 or 14.4.3 does not constitute acceptance of Work not complying with the requirements of the Contract Documents. The making of final payment does not constitute a waiver of claims by the Owner as provided in Subsection 14.4.5.

**4.4.7 Occupancy or Use.** Partial or entire occupancy or use of a portion or portions of the

Work by the Owner under Section 14.1 does not constitute acceptance of Work not complying with the requirements of the Contract Documents.

**4.4.8 Certificate of Substantial or Final Completion.** Neither the issuance by the Architect/Engineer of a Certificate of Substantial or Final Completion under Subsections 14.2.6 or 14.4.1, nor acceptance thereof by the Owner, constitutes acceptance of Work not complying with the requirements of the Contract Documents.

## ARTICLE 5

---

### CONTRACTOR

#### 5.1 REVIEW OF CONTRACT DOCUMENTS AND FIELD CONDITIONS

**5.1.1 Review of Site Conditions.** By executing the Contract, the Contractor represents that the Contractor has reviewed and understands the Contract Documents, has visited the Site and is familiar with local conditions under which the Work is to be performed, has correlated personal observations with the requirements of the Contract Documents, and has notified the Architect/Engineer of and obtained clarification of any discrepancies which have become apparent during the bidding or proposal period.

**5.1.2 Review of Contract Documents.** The Contractor must carefully study and compare the Contract Documents among themselves and further compare the Contract Documents with any other information furnished by the Owner pursuant to Section 3.2 before commencing Work at the Site and at frequent intervals during its progress.

**5.1.3 Field Measurements and Site Conditions.** The Contractor must take field measurements and verify Site conditions, and must carefully compare such field measurements and Site conditions and other information known to the Contractor with the Contract Documents, before ordering any material or doing any Work at the Site.

**5.1.4 Inspection of Work.** The Contractor must make frequent inspections during the progress of the Work to confirm that Work previously performed by the Contractor is in compliance with the Contract Documents and applicable laws and regulations and Referenced Standards and that portion of Work previously performed by the Contractor or by others are in proper condition to receive subsequent Work.



**5.1.5 Compliance of Contract Documents with Laws and Regulations and Referenced Standards.** If the Contractor believes that any portions of the Contract Documents do not comply with applicable laws, statutes, ordinances, building codes, and rules and regulations, or any orders by code enforcement officials or the Owner or its designees acting in the capacity of building code inspectors or Referenced Standards, the Contractor must promptly notify the Owner and the Architect/Engineer of the non-compliance as provided in Subsection 5.1.6 and request direction before proceeding with the affected Work.

**5.1.6 Notice of Discrepancies.** The Contractor must promptly notify the Owner and the Architect/Engineer in writing of any apparent errors, inconsistencies, omissions, ambiguities, construction impracticalities or code violations discovered as a result of the Contractor's review of the Contract Documents including any differences between actual and indicated dimensions, locations and descriptions, and must give the Owner and the Architect/Engineer timely notice in writing of same and of any corrections, clarifications, additional Drawings or Specifications, or other information required to define the Work in greater detail or to permit the proper progress of the Work. The Contractor must provide similar notice with respect to any variance between its review of the Site and physical data and Site conditions observed.

**5.1.7 Risk of Performance.** If the Contractor performs any Work involving an apparent error, inconsistency, ambiguity, construction impracticality, omission or code violation in the Contract Documents of which the Contractor is aware, without prompt written notice to the Owner and the Architect/Engineer and request for correction, clarification or additional information, as appropriate, the Contractor does so at its own risk and expense and all Claims relating thereafter are specifically waived. Notwithstanding the foregoing, the Owner acknowledges that the Contractor is not required to ascertain that the Contract Documents are in accordance with applicable laws, statutes, ordinances, codes, rules and regulations, or lawful orders of public authorities.

## **5.2 LEGAL REQUIREMENTS**

**5.2.1 Compliance with Laws, Regulations and Orders.** The Contractor must obtain all licenses and comply with and give all notices required by laws, ordinances, rules, regulations

and lawful orders of public regulatory authorities bearing on performance of the Work, including the orders of the Owner or its designees acting in the capacity of building code inspectors. The Owner acknowledges that the Contractor is not required to ascertain that the Contract Documents are in accordance with applicable laws, statutes, ordinances, codes, rules and regulations, or lawful orders of public authorities. The Contractor shall promptly report to the Architect any errors, inconsistencies or omissions it discovers. It is recognized that the Contractor's review of Contract Documents is made in the Contractor's capacity as a contractor and not as a licensed design professional.

**5.2.2 Taxes.** The Contractor must pay sales, consumer, use and similar taxes for the Work or portions thereof which are legally enacted when Bids or Proposals are received or negotiations concluded or which are enacted thereafter, whether or not yet effective or merely scheduled to go into effect. The Contractor is on notice that under Md. Code Ann., Tax-Gen'l, §11-220(b) (2004 Repl. Vol.), purchases made by the Contractor in furtherance of this Contract are not exempt from Maryland sales and use taxes by virtue of the Owner's status as a local government entity.

**5.2.3 Permits and Fees.** Unless otherwise provided in Section 3.3.2 or in the Contract Documents, the Contractor must obtain and pay for all permits and governmental fees, licenses and inspections necessary for proper execution and completion of the Work, including connections, tap fees and inspections in connection with the installation of utilities and any bonds required by any utilities for the performance of any utility Work on utility lines or within a utility easement, specialized trade permits such as for plumbing, mechanical and electrical work, and any fees and charges associated therewith which have been enacted or established at the time Bids or Proposals are received or negotiations concluded or which are enacted thereafter;

**5.2.4 Compliance with U.S. Green Building Council's Leadership in Energy and Environmental Design (LEED) Requirements.** If a LEED certification level is specified in the Contract Documents, the Contractor must perform all contractor-responsible work in a manner to attain all specified LEED points, as defined by the U.S. Green Building Council (USGBC). The Contractor shall be solely responsible for planning, scheduling, performing,

and documenting each LEED requirement for which the Contractor is responsible. The Contractor shall notify the Owner and the A/E of any questions concerning its LEED responsibilities within fifteen (15) days of the Notice to Proceed.

The Contractor shall be responsible for coordinating with, and providing documentation as required by, the Montgomery County Department of Permitting Services (MCDPS) to demonstrate that the Work was done in accordance with LEED requirements and to allow MCDPS to issue a temporary use and occupancy permit at Substantial Completion.

Throughout the project, the Contractor shall coordinate with, and provide documentation to, the A/E to verify its compliance with LEED requirements. Before Substantial Completion, the Contractor shall provide all required LEED documentation to the A/E to enable the A/E to submit a full LEED package to the USGBC to verify that the Work was done in accordance with LEED requirements and to allow USGBC to issue certification of the project at the specified LEED level.

If the USGBC determines that the Project does not satisfy some of the specified LEED credits, and/or if the USGBC determines that the Project fails to obtain the specified LEED certification level, and the failure to obtain these specified LEED credits and/or certification is a result of the Contractor's failure to fulfill its contractual obligations, the Contractor shall, at the request of the County: (i) Correct all deficiencies in the Work to achieve the required credits and/or level of certification; and (ii) Pay to the Owner actual damages resulting from the Contractor's failure to perform its LEED requirements.

### **5.3 CONTRACTOR'S RESPONSIBILITY FOR PERFORMANCE**

**5.3.1 Assignment, Scheduling and Coordination.** The Contractor is solely responsible for and has control over assigning, scheduling and coordinating all portions of the Work under the Contract performed by the Contractor's own forces and by its Subcontractors, Sub-subcontractors and Suppliers in accordance with the CPM Schedule of Record, unless the Contract Documents give other specific instructions concerning these matters.

### **5.3.2 Construction Means and Methods.**

The Contractor must provide continuous on-Site supervision and direction of the Work using the Contractor's best efforts. The Contractor has control over construction means, methods, techniques, sequences and procedures, unless the Contract Documents give other specific instructions concerning these matters, and is solely responsible therefore.

**5.3.3 Discipline at the Site.** The Contractor must enforce strict discipline and good order among the Contractor's employees and other persons for whose Work the Contractor is responsible, including Contractors, Subcontractors, Sub-subcontractors, and Suppliers.

**5.3.4 Responsibility for Subordinates.** The Contractor is responsible for the acts and omissions of all persons performing portions of the Work at the Site, including but not limited to the Contractor's employees, Subcontractors, Sub-subcontractors, Suppliers, and the agents and employees of any of them.

**5.3.5 Obligations Not Relieved.** The Contractor is not relieved of its obligations to perform the Work in accordance with the Contract Documents, or to comply with applicable laws and regulations and Referenced Standards, by the activities or duties of the Owner or the Architect/Engineer in the administration of the Contract or of construction, or by tests, inspections or approvals required or performed by persons other than the Contractor.

## **5.4 SUPERINTENDENCE**

**5.4.1 Superintendent.** The Contractor must employ a competent Superintendent and necessary assistants who represent the Contractor who must be in attendance at the Site at all times during the performance of the Work or any other operations by the Contractor at the Site until issuance of the Certificate of Substantial Completion, during the performance of any punch list work, and for such additional time thereafter as the Owner or Architect/Engineer may determine to be necessary for Final Completion.

**5.4.2 Acceptability of Key Personnel.** The Contractor's key project-specific personnel (including at a minimum the Superintendent, Project Manager and Quality Control Manager, as required by the Contract Documents) are subject to approval by the Owner and a list of them and their resumes in the form required by the Owner must be provided to the Owner in

accord with Subsection 9.1.2.4. If the Owner advises the Contractor that any such personnel are unsatisfactory to the Owner, then the Contractor must promptly provide an acceptable substitute. If the Owner determines, during the Contractor's performance of the Work, that any such personnel are unsatisfactory, then the Contractor must promptly provide an acceptable substitute. The Contractor may not voluntarily change the Superintendent or key personnel without prior notice to and the consent of the Owner, not to be unreasonably withheld. The Owner may condition its consent on the Contractor's fully familiarizing the replacement personnel with all Contract Documents and the status of the Work at the Contractor's expense.

**5.4.3 Communications with Superintendent and Project Manager and Owner's Representatives and/or the Architect /Engineer.** The Superintendent and Project Manager must be fluent in written and spoken English, and communications given to the Superintendent or Project Manager are as binding as if given to the Contractor. If the Contractor contends that any communication between its Superintendent and Project Manager and any Owner's representative or the Architect/Engineer constitutes a change in the Work entitling the Contractor to an increase in the Contract Time or Contract Sum, the Contractor must before proceeding with the work obtain the written authorization of the Contract Administrator directing the performance of the work and must file notice with the Owner and Architect/Engineer in accordance with Section 12.5, and file a Claim for an increase in the Contract Time and/or a Claim for an increase in the Contract Sum in accordance with Articles 11 and 12, or any Claim relating to such Work shall be deemed waived.

## **5.5 LABOR, MATERIALS AND EQUIPMENT**

**5.5.1 Labor, Materials and Equipment Provided by Contractor.** Unless otherwise provided in the Contract Documents, the Contractor must provide and pay for all labor, materials, equipment, and utilities required for the performance of the Contract.

**5.5.2 Royalties and License Fees.** The Contractor must pay all royalties and license fees and comply with any licensing requirements required in connection with the use of a particular design, process or product of a particular manufacturer or manufacturers. The Contractor must defend suits or claims for infringement of copyrights, patent rights or trade

secrets and must hold the Owner and Architect/Engineer harmless from liability and indemnify the Owner and Architect/Engineer against any loss or damage on account thereof.

**5.5.3 Compliance with Contract Documents, Approved Submittals, and Interpretations.** The Contractor must perform the Work in accordance with: (i) the Contract Documents; (ii) Submittals approved pursuant to Section 9.2 to the extent they are not in conflict with the Contract Documents; and (iii) interpretations and instructions issued by the Architect/Engineer pursuant to Subsection 4.3.1.

**5.5.4 Compliance with Manufacturers' Instructions.** Unless otherwise specifically provided in the Contract Documents, the Contractor must store, handle, install, and test all materials and equipment in accordance with the manufacturers' or Suppliers' most recent instructions and recommendations. In the event such instructions or recommendations are in conflict with any provisions of the Contract Documents, the Contractor must give prompt notice of the conflict to the Owner as provided in Subsection 5.1.6.

**5.5.5 Labor.** The Contractor must provide, and must also ensure that its Subcontractors and Sub-subcontractors provide, a sufficient number of properly skilled workers and crews to perform the Work in a safe and expeditious manner in accordance with the approved Progress Schedule, including appropriate proportions of laborers, apprentices, journeymen, masters and foremen, and must not permit employment of persons who are unfit to perform or are not skilled in tasks assigned to them.

**5.5.6 Allowances.** The Contract Sum and Contract Time include all Allowances required by the Contract Documents. The Contractor must perform all Work covered by an Allowance unless directed otherwise by the Owner. The Contractor must provide proposed or actual costs to the Owner for performing any Allowance work. If acceptable to the Owner, the Owner will then direct the Contractor to perform the Work through written notification. The Owner may require that work covered by an Allowance be purchased on the basis of the lowest responsive bid of at least three competitive bids approved by the Owner, unless the Contract Documents specify a Unit Price for the work, in which case the Allowance work must be provided at the Unit Price. Work covered by Allowances must be supplied for such amounts and by such persons

or entities proposed by the Contractor and approved by the Owner or as the Owner may otherwise direct, unless the Contract Documents specify a Unit Price for the work, in which case the work must be provided at the Unit Price.

**5.5.7 Adjustments for Allowances.** Unless otherwise provided in the Contract Documents:

- .1 Allowances designated in the Contract Documents provide for the estimated direct cost of all labor, materials and equipment, including unloading, storage, and handling at the Site, labor, installation costs, transportation to the Site and all required taxes, less applicable trade discounts **but do not include the Contractor's overhead or profit, which are included in the Contract Sum and are not compensable under the Allowances;**
- .2 Whenever actual costs (excluding those amounts indicated above as included in the Contract Sum and not compensable) are more than a monetary Allowance, the Contractor shall be entitled to an appropriate Contract Modification to reflect the difference between the costs set forth in subsection .1;
- .3 If actual costs are less or equal to the amount of a monetary Allowance, the Contractor shall include only such actual costs in the Contractor's Application for Payment; the Contract Sum must be reduced by an appropriate Contract Modification to reflect the deletion of an Allowance or lower actual costs of an Allowance; and
- .4 **All time required for the performance of work covered by an Allowance is conclusively presumed to be included in the Contract Time, unless the cost of the work exceeds the Allowance amount and the Contractor demonstrates a Delay to the critical path of the CPM Schedule of Record and requests an increase of time in accordance with Article 11.**

## **5.6 CONSTRUCTION OPERATIONS**

**5.6.1 Use of Site.** The Contractor must confine operations at the Site to areas permitted by law, ordinances, permits, and the Contract

Documents and must not unreasonably encumber the Site with materials and equipment. The Owner may establish reasonable additional limitations on the Contractor's use of the Site to accommodate the needs of the Owner, Separate Contractors, users of occupied facilities the public, or other forces authorized by the Owner to perform work. Provided, however, if such limitations are made known to the Contractor after the date bids are received, the Contractor may be entitled to an equitable adjustment in the Contract Time and/or Contract Sum if the Contractor can demonstrate that such limitations adversely impact the prosecution of the Work.

**5.6.2 Benchmarks and Layout of Work.** The Contractor must establish the exterior lines and elevations of all buildings and structures to be erected on the Site, and lines and grades of Site Work such as roads, utilities and Site grading, based on reference points, the location of existing structures or improvements, or benchmarks identified in the Contract Documents or Site Surveys provided by the Owner. The Contractor must protect and preserve such established reference points, and if they are disturbed, the cost of their relocation and replacement must be borne by the Contractor. The Contractor must provide a professional certification by a **State of Maryland** registered professional engineer or land surveyor as to the actual location of building lines prior to the construction of the foundations. **Once foundation work is complete, and prior to commencing construction of the superstructure for the Project, Contractor must submit to Owner a certified building location survey as completed by a State of Maryland registered land surveyor.** The Contractor must establish the building grades, lines and levels, and column, wall and partition lines required by its Subcontractors in laying out their Work. At the completion of the Work, the Contractor must provide another professional certification by a registered professional engineer or land surveyor as to the location of the completed improvements in relation to property lines, building lines, easements, and other boundaries.



**5.6.3 Working Hours.** Except as otherwise provided in the Contract Documents, all Work must be performed between the hours of 7:00 a.m. and 4:00 p.m. Monday through Friday exclusive of County, State and federal holidays unless more restrictive hours are required by the Montgomery County Code or other applicable law governing the Contractor's performance of the Work. The Owner has the right to impose further restrictions on working hours reasonably related to the use of occupied facilities provided, however, the Contractor shall be entitled to an equitable adjustment in the Contract Time and/or Contract Sum if such restrictions are imposed after the date bids are received if the Contractor can demonstrate that such limitations adversely impact the prosecution of the Work. No delays resulting from compliance with applicable laws or regulations may form the basis for any Claim by the Contractor for delay damages or additional compensation or for any increase in the Contract Time; any delays arising from restrictions related to the use of occupied facilities are non-compensable and any requests for an increase in the Contract Time relating to them must be filed in accord with Article 11 or the same will be conclusively deemed to have been waived. The Contractor must not permit work outside of such hours or on a Saturday, Sunday or other County, State or federal holiday without the written consent of the Owner, given after prior written notice to the Architect/Engineer; such consent, if given, may be conditioned upon payment by the Contractor of the Owner's and Architect/Engineer's additional costs and fees incurred in monitoring such off-hours Work. The Contractor must notify the Owner as soon as possible if Work must be performed outside such times in the interest of the safety and protection of persons or property at the Site or adjacent thereto, or in the event of an emergency. In no event shall the Contractor permit Work to be performed at the Site without the presence of the Contractor's Superintendent and/or persons responsible for the protection of persons and property at the Site and compliance with all applicable Laws and Regulations, if different from the Superintendent.

**5.6.4 Noise Ordinance.** The Contractor must comply with the Montgomery County Noise Ordinance (Chapter 31B) of the Montgomery County Code and any successor or substitute provisions covering the regulation of noise levels. It is the duty of the Contractor to familiarize itself with those provisions and

perform the Work in compliance with those provisions.

**5.6.5 Temporary Facilities.** Except as otherwise provided in the Contract Documents, the Contractor must provide and pay for all labor, materials, equipment, tools, construction equipment and machinery, water, heat, utilities, transportation, and other temporary facilities and services necessary for proper execution and completion of the Work, including measures for sediment control, storm water management and waste disposal. The Contractor must not use any preexisting facilities of the Owner without the specific written consent of the Owner, except as indicated in the Contract Documents. The Contractor is solely responsible for temporary facilities and services provided or utilized by the Contractor and must remove those not required to remain at the completion of the Work or any portion thereof; must promptly correct any damage caused by the erection, use or removal of temporary facilities; and must restore the Site and any adjacent areas to their original condition or that required by the Contract Documents upon completion of the Work.

**5.6.6 Cutting, Patching and Finishing.** The Contractor is responsible for all cutting, patching and finishing required to complete the Work or to make its parts fit together properly. The responsibility of the Contractor, Owner and Separate Contractors with respect to cutting, patching and finishing work by others is as provided in Subsection 7.2.4.

**5.6.7 Cleaning Up.** The Contractor must keep the Site and adjacent areas free from accumulation of waste materials or rubbish caused by operations under the Contract, and must keep tools, construction equipment, machinery and surplus materials suitably stored when not in use. If the Contractor fails to do so in a manner reasonably satisfactory to the Owner or the Architect/Engineer within forty-eight (48) hours after notice or as otherwise required by the Contract Documents, the Owner may clean the Site and back charge the Contractor for all costs associated with the cleaning.

**5.6.8 Utilities.**

**.1 Temporary Utilities.** Unless otherwise specified in the Contract Documents, the Contractor, at its own expense, must:

- (1) Furnish all temporary heat, cooling ventilation, and humidity control

including all required apparatus and fuel as may be necessary to protect the Work fully, both during its execution and until Final Completion and acceptance. Contractor must not use any method of heating, cooling, ventilation, or humidity control of the building unless approved by the Owner in advance;

- (2) Provide all temporary on-Site water service required to perform the Work, to assure safety at the Site, and as otherwise specified in the Contract Documents. All temporary service must be removed by Contractor unless otherwise specified in the Contract Documents;
- (3) Furnish all temporary electric service required to perform the Work, to assure safety at the Site, and as otherwise specified in the Contract Documents;
- (4) Furnish all temporary telephone and data service required to perform the Work, to assure safety at the Site, and as otherwise specified in the Contract Documents; and
- (5) The Contractor must provide and maintain in a neat, sanitary condition such accommodations for the use of the Contractors and Subcontractors employees as may be necessary to comply with the requirements and regulations of the Department of Health and Human Services of Montgomery County, or of other authorities having jurisdiction, and shall commit no public nuisance.

## .2 Existing Utilities.

- (1) The existence and locations of underground or other utilities and other construction indicated on the plans are not guaranteed by Owner.
- (2) Contractor must investigate and verify the existence and location of underground or other utilities before commencing the Work. Work performed near existing structures and utilities must be done safely by hand. Contractor is responsible for any damage to,

and for maintenance and protection of, existing utilities and structures.

- (3) At Contractor's expense the Contractor must coordinate with utilities companies for the adjustment, moving or relocation as necessary of existing structures, utility poles, lines, services, or other appurtenances located in, or affected by, the Work which was discoverable by a thorough site visit, and/or a careful review of the Contract Documents. No increase in the Contract Time or an increase in the Contract Sum will be granted for any Delay associated with such coordination whether caused by the Contractor, a public utility, any other third party or the Owner acting in its governmental capacity. The Contractor will be allowed an increase in the Contract Sum and/or an increase in the Contract Time associated with the adjustment, removal, or relocation of any operational but unknown and unmarked utilities which were not discoverable by a thorough site visit, and/or a careful review of the Contract Documents. Any Claim for adjustment of the Contract Time or the Contract Sum must be filed within the time and in accordance with the provisions of Articles 11 and 12 or any Claim to such will be deemed to have been conclusively waived.

## .3 Permanent Utilities.

- (1) Contractor must arrange for and coordinate the installation and inspection of permanent utilities with all appropriate utility companies. The installation cost and the time associated with such work is included in the Contract Time and the Contract Sum unless otherwise specified in the Contract Documents. **No increase in the Contract Time or an increase in the Contract Sum will be granted for any Delay associated with obtaining such permanent utilities**

whether caused by the Contractor, a public utility, any other third party or the Owner acting in its governmental capacity. The Contractor is responsible for the costs for its use of permanent utilities until Substantial Completion.

#### 5.6.9 Air Pollution Control

- .1 The Contractor must comply with the Montgomery County Air Quality Ordinance (Chapter 3) of the Montgomery County Code and any successor or substitute provisions covering the regulation of air quality.
- .2 Hauling of Materials: All fine-grained loose materials hauled to or from a project must be covered to prevent spillage and blowing.
- .3 Disposal of Materials: Disposal of materials by burning at any location within the project site is prohibited. Any off-site burn area receiving materials from the project site must have a Fire Permit from the Montgomery County Department of Environmental Protection and conform to all laws and regulation associated with said Fire Permit.

## ARTICLE 6

### SUBCONTRACTORS AND SUPPLIERS

#### 6.1 SELECTION AND RIGHT OF REJECTION

**6.1.1 Identification of Subcontractors and Suppliers.** Unless otherwise provided in the Contract Documents or the Instructions to Bidders, the Contractor, within ten (10) days after issuance of the Notice to Proceed and before commencing Work at the Site, must furnish in writing to the Owner through the Architect/Engineer the names of Subcontractors and Suppliers which the Contractor intends to utilize during the first thirty (30) days, and those then known to the Contractor who are proposed for each principal portion of the Work. This list must be consistent with the Contractor's

Progress Schedule required by Subsection 11.2.1 and Schedule of Submittals required by Subsection 11.2.6. Such principal Subcontractors include, but are not limited to, (i) those performing ten percent (10%) or more of the amount of the Work as indicated by the Contractor's Schedule of Values; (ii) any Subcontractor whose Work falls on the critical path of the Contractor's Progress Schedule, and (iii) those responsible for excavation, structural steel, concrete, masonry, plumbing, mechanical, electrical, roofing and finish work. The Contractor must submit any proposed changes or additional names as the Work progresses, not less than thirty (30) days prior to the date on which the Contractor intends to contract with the proposed Subcontractor or Supplier, and sufficiently in advance of such date to permit a reasonable time for review.

- .1 The Contractor must not enter into any subcontract, contract, agreement, purchase order or other agreement for the furnishing of any portion of the materials, services, equipment or Work with any party or entity if such party or entity is an Affiliated Entity with which the Contractor has a direct or indirect ownership, control or interest unless such agreement has been approved by the Owner, such approval not to be unreasonably withheld, after full disclosure in writing by the Contractor to the Owner of such affiliation or relationship and all details relating to the proposed arrangements.
- .2 The Contractor shall submit the name of all principal Subcontractors to the Owner within sixty (60) days after Notice to Proceed and shall have all principal Subcontractors under contract within ninety (90) days of Notice to Proceed.

**6.1.2 Qualification of Subcontractors** The Owner may make such investigations as he deems necessary to determine the ability of any Subcontractor to perform its work, and the Contractor and Subcontractor shall furnish to the Owner all such information and data for this purpose as the Owner may request. The Owner may visit any Subcontractor's place of business and review any other factors relevant to a determination of the Subcontractor's ability to perform its work. The Owner reserves the right to reject any Subcontractor who has previously failed to perform properly or to complete in a

timely manner, or whose proposed Subcontractors, Suppliers, or Surety have similarly failed to perform properly or timely, contracts of a similar nature, or if investigations show the Subcontractor unable to perform the requirements of the Subcontract.

.1 Upon Owner request, Subcontractors shall furnish under oath the following proof of qualifications to perform its proposed work. Subcontractor shall furnish a description of comparable work performed by him within the previous five years indicating the location, contract scope, contract sum, type of construction, name, address and phone number of owner and architect, date work completed, and construction period in days. Upon Owner request, Subcontractors may be required to furnish additional information as proof of qualifications. Failure to submit any requested information within 10 days of Owner request shall be sufficient cause to reject the Subcontractor.

.2 Upon Owner request, Subcontractors shall furnish a current condensed net worth statement and financial references for verification of financial responsibility.

.3 All Subcontractors must be licensed, as required by law, to perform its proposed work. Upon Owner request, Subcontractors shall furnish evidence of required licenses.

**6.1.3 Acceptance of Subcontractors and Suppliers.** The Architect/Engineer will, within a reasonable time, advise the Contractor in writing if the Owner rejects any proposed Subcontractor or Supplier, stating the reasons therefore, or stating that additional information is required in order to make a determination as to the acceptability of any proposed Subcontractor or Supplier.

**6.1.4 Use of Acceptable Subcontractors and Suppliers.** The Contractor must not contract with a proposed Subcontractor or Supplier who has been rejected by the Owner. If the Contractor wishes to change a previously-selected Subcontractor or Supplier, the Contractor must submit the name of the replacement for review and acceptance as provided in Subsection 6.1.1.

**6.1.5 Owner's Right to Require Removal.** The Owner has the right to require the Contractor to remove a Subcontractor or Supplier, for any occurrence which, if done by the Contractor, would be a breach of the Contract.

**6.1.6 Replacement Subcontractors and Suppliers.** If the Owner requires removal of a Subcontractor or Supplier, the Contractor must propose another to whom the Owner has no reasonable objection. The Contractor is not entitled to any adjustment in the Contract Time or the Contract Sum occasioned by such change if the removal is for any occurrence which, if done by the Contractor, would be a breach of the Contract, or if the Contractor has failed to act promptly and responsively in submitting names as required.

## **6.2 SUBCONTRACTUAL RELATIONS**

**6.2.1 Subcontracts Required.** The Contractor must require each Subcontractor, to the extent of the Work to be performed by the Subcontractor, to be bound to the Contractor by the terms of the Contract Documents, and to assume toward the Contractor all the obligations and responsibilities which the Contractor, by the Contract Documents, assumes toward the Owner and the Architect/Engineer. Each subcontract must allow to the Subcontractor, unless otherwise agreed to by the Owner, rights, remedies and redress against the Contractor equivalent to those that the Contractor, by the Contract Documents, has against the Owner. The Contractor must require each Subcontractor to enter into similar agreements with Sub-subcontractors.

**6.2.2 Intentionally Not Used.**

**6.2.3 Subcontract Provisions.** The Contractor must submit a copy of each subcontract to the Owner upon request. Each subcontract must specifically include provisions that:

- .1 Preserve and protect the rights of the Owner under the Contract with respect to the Work to be performed under the subcontract so that the subcontracting thereof will not prejudice such rights;
- .2 Require the Subcontractor to comply with all applicable licensing, bonding and insurance requirements;
- .3 Require submission to the Contractor of submittals in sufficient time and in



such detail as will enable the Contractor to review, approve and submit such submittals in accordance with Article 9;

- .4 Require that the Work under the subcontract be performed in accordance with the requirements of the Contract Documents and applicable laws and regulations.
- .5 Require the Subcontractor to comply with all applicable employment laws, regulations and requirements of the Contract, including requirements concerning equal employment opportunity and affirmative action and Minority Female and Disabled (MFD) requirements applicable to Subcontractors;
- .6 Require submission to the Contractor of applications for payment in sufficient time and in such detail as will enable the Contractor to apply for payment in accordance with Article 13, and provide for payment to Subcontractors as provided in Section 6.3;
- .7 Require that all requests and/or Claims for additional costs, increase of time, damages for delays or otherwise with respect to subcontracted portions of the Work for which the Owner, the Architect/Engineer, any Separate Contractor, or any of their consultants, subcontractors, agents or employees might be liable, be submitted through the Contractor in sufficient time and in such detail as will enable the Contractor to comply with the requirements of Articles 11, 12 and 16 for such requests or Claims;
- .8 Require the Subcontractor to indemnify as provided in Section 8.4;
- .9 Expressly provide for the contingent assignment referred to in Section 6.4;
- .10 Obligate the Subcontractor specifically to consent to the provisions of this Section; and
- .11 Allow the Subcontractor and applicable Sub-subcontractor to be terminable at no cost to the Owner or the Contractor if the Contract is terminated.

## **6.3 PAYMENTS TO SUBCONTRACTORS AND SUPPLIERS**

**6.3.1 Payments by Contractor to Subcontractors and Suppliers.** As required by Md. Code Ann., Real Prop., §9-302 (2003 Repl. Vol.), the Contractor shall pay each Subcontractor and Supplier, within seven (7) days after receipt of payment from the Owner that portion of the amount paid to the Contractor on account of such Subcontractor's or Supplier's portion of the Work to which the Subcontractor or Supplier is entitled. Retainage withheld from payments to a Subcontractor or Supplier must not exceed the contract retainage applicable to the Contractor on account of that Subcontractor's or Supplier's portion of the Work. The Contractor and Subcontractors are put on notice that payments made to them under the Contract are held in trust for their Subcontractors and Suppliers under Md. Code Ann., Real Prop., §9-201 (2003 Repl. Vol.).

### **6.3.2 Intentionally Not Used.**

**6.3.3 Substantial Completion Payment and Final Payment to Subcontractors and Suppliers.** The Contractor must make payment (excluding retainage, amounts withheld for completion of Punch List and correction of any defective Work) to Subcontractors and Suppliers within a reasonable time after Substantial Completion of the Work. Remaining retainage payments and any amounts previously withheld for completion of Punch List and correction of any defective Work must be made to Subcontractors and Suppliers within seven (7) days after receipt of final payment by the Contractor.

### **6.3.4 Intentionally Not Used.**

**6.3.5 Information Regarding Payments.** The Owner may at its discretion, and the Architect/Engineer may if so authorized by the Owner, furnish directly to a Subcontractor or Supplier on its request, if practicable, information regarding the Contract, including percentages of completion claimed or amounts applied for by the Contractor and action taken thereon by the Architect/Engineer and Owner on account of portions of the Work done by such Subcontractor or Supplier.

**6.3.6 Responsibility for Payment to Subcontractors.** Neither the Owner nor the Architect/Engineer shall have any obligation to pay or to see to the payment of any moneys to any Subcontractor or Supplier or provide any

information to either. Notwithstanding any provision to the contrary in this Article 6 or in any other provision of the Contract Documents, any obligations imposed upon the Contractor with respect to Subcontractors and Suppliers is solely for the benefit of the Owner and Architect/Engineer and shall not be construed as giving any Subcontractor or Supplier any rights against the Owner or the Architect /Engineer or creating any privity of contract between the Owner and Architect/Engineer on one hand and any Subcontractor or Supplier on the other hand.

#### **6.4 CONTINGENT ASSIGNMENT OF SUBCONTRACTS AND PURCHASE ORDERS**

**6.4.1 Assignment.** Each subcontract and Contractor's purchase order for a portion of the Work, including contracts for the purchase or rental of temporary facilities and equipment, must be assignable by the Contractor to the Owner under the conditions of this Section at no cost or change in price or time of performance on account of the assignment.

**6.4.2 Election by Owner.** The assignment of subcontracts and Contractor's purchase orders is effective only after termination of the Contract by the Owner pursuant to Sections 15.2 or 15.3, and only for those subcontracts or purchase orders which the Owner accepts by notifying the Contractor and Subcontractor or Supplier in writing.

**6.4.3 Rights of Surety.** The assignment of subcontracts and Contractor's purchase orders is subject to the prior rights of the Surety, if any, on the Project.

**6.4.4 Liability for Prior Obligations.** In the event the Owner accepts an assignment, the Owner is not liable for any obligations of the Contractor to the Subcontractor or Supplier arising prior to the effective date of the assignment, other than payment for Work performed in accordance with the Contract Documents and for which the Owner has not made payment to the Contractor. In no event does such assignment act as a release of the Contractor or its Surety from any of their obligations to the Owner, the Subcontractor, Supplier, or any other person or entity affected thereby. The Contractor must insert a provision to this effect and to the effect of Subsection 6.4.1 in all contracts with its Subcontractors and Suppliers and require all Subcontractors to insert a similar provision in all contracts with any Sub-subcontractor.

## **ARTICLE 7**

### **WORK BY OWNER AND BY OTHERS**

#### **7.1 OTHER WORK AT THE SITE**

**7.1.1 Owner's Rights Reserved.** The Owner reserves the right to perform work at the Site with its own forces, to permit work to be performed at the Site by other forces, and to award separate contracts in connection with other portions of the Project.

**7.1.2 Identification of Work by Others.** Work to be performed by the Owner or by Separate Contractors is identified as such in the Contract Documents. If a question arises concerning the allocation of responsibilities among the Contractor and the Owner or any Separate Contractor, the Contractor must promptly request an interpretation or decision as provided in Subsection 4.3.3.

**7.1.3 Coordination of Other Work.** The Contractor must cooperate in coordinating its Work with the work, if any, of the Owner, Separate Contractors, and any other forces permitted by the Owner to perform work at the Site without an increase in the Contract Time or the Contract Sum. The Contractor must, in addition, coordinate its Work with other work at the Site as required in the Contract Documents without an increase in the Contract Time or the Contract Sum. Such coordination will be performed as designated in the Contract Documents by the Owner the Architect/Engineer, a separate consultant retained by the Owner such as a construction manager, or may be assigned to the Contractor or a Separate Contractor, and any such assignment shall be without an increase in the Contract Time or in the Contract Sum. In the event such coordination is not performed by the Owner's own personnel, the Owner will advise the Contractor in writing of the person or entity who will be responsible for such coordination, and will describe the duties, authority and limitations of authority of such person or entity.

**7.1.4 Construction Schedules.** In the event the Owner is performing work at the Site with its own forces or by Separate Contractors or permitting other forces to perform work at the Site, the Owner will be responsible for providing the Contractor with appropriate and necessary activities, durations, and/or fragnets indicating the work and that such information shall be input into the Contractor's Project Schedule. The Contractor must participate with the Owner and any Separate Contractors and other forces permitted by the Owner to perform work at the

Site in jointly reviewing the overall Project Progress Schedule when directed to do so. The Contractor must make any revisions to the Contractor's Progress Schedule that are necessary to accommodate work by the Owner and Separate Contractors and any other forces permitted by the Owner to perform work at the Site and to avoid delays and interruptions in the overall Project Progress Schedule. **The Contractor may be entitled to a change in the Contract Time or Contract Sum as a result of any Delays, impacts or inefficiencies resulting from interferences or lack of Site availability caused by Owner or Separate Contractors or other forces permitted by the Owner to perform work at the Site provided Contractor submits a Claim in accordance with Articles 11, 12 and 16.**

**7.1.5 Communications through Owner.** Communications among the Contractor and Separate Contractors must be conducted through the Owner, except as provided in Subsections 7.2.4 and 7.2.5.

## **7.2 CONTRACTOR'S RESPONSIBILITY**

**7.2.1 Contractor to Afford Access to Others.** The Contractor must afford the Owner and Separate Contractors and other forces permitted by the Owner to perform work at the Site reasonable opportunity for introduction and storage of their materials and equipment and performance of their work and related activities.

**7.2.2 Connection with Other Work.** The Contractor must connect its Work with that of the Owner and Separate Contractors and other forces permitted by the Owner to perform work at the Site as required by the Contract Documents, the overall Project Progress Schedule, and the directions of the Owner and its authorized representatives.

**7.2.3 Inspection and Notice of Unsuitability.** If part of the Contractor's Work or other operations depends for proper execution or results, upon, or may adversely be affected by, construction or operations by the Owner or a Separate Contractor or other forces permitted by the Owner to perform work at the Site, the Contractor must, as soon as practicable but in all events in sufficient time to prevent delay, disruption, hindrance or interference with the performance of the Contractor's work and prior to proceeding with that portion of the Work, report in writing to the Architect/Engineer and the Owner any apparent discrepancies or defects in, or other conditions pertaining to, such other construction or operations that would

prevent the Contractor from achieving proper execution and results of the Work. **Failure of the Contractor to report such conditions prior to proceeding with the Work constitutes an acknowledgment (i) that the construction by the Owner or Separate Contractors or other forces permitted by the Owner to perform work at the Site is fit and proper to receive the Contractor's Work, except as to defects not then reasonably discoverable, and (ii) that their operations will not adversely affect the performance of the Work.**

**7.2.4 Cutting, Patching and Finishing of Work by Others.** The Contractor must not damage or endanger fully or partially completed construction by the Owner or Separate Contractors or other forces permitted by the Owner to perform work at the Site by cutting, patching, finishing or otherwise altering such construction, or by excavation. The Contractor must not cut or otherwise alter such work by others except with written consent of the Owner; such consent will not be unreasonably withheld. The Contractor must not unreasonably withhold from the Owner or a Separate Contractor or other forces permitted by the Owner to perform work at the Site the Contractor's consent to cutting, patching, finishing or otherwise altering the Contractor's Work.

**7.2.5 Remedy of Damage to Work by Others.** The Contractor must promptly remedy damage caused by the Contractor to completed or partially completed construction or to property of the Owner or Separate Contractors or other forces permitted by the Owner to perform work at the Site as provided in Subsection 8.2.7.

## **7.3 MUTUAL RESPONSIBILITY OF THE OWNER AND SEPARATE CONTRACTORS**

**7.3.1 Responsibility for Cleaning Up.** If a disagreement arises among the Contractor, Separate Contractors or other forces permitted by the Owner to perform work at the Site and the Owner as to their respective responsibilities for maintaining the Site, the Work and surrounding area free from waste materials and rubbish as described in Subsection 5.6.6, the Owner may clean up or direct the Contractor or a Separate Contractor or other forces permitted by the Owner to perform work at the Site to do so, and allocate the cost thereof among them.

**7.3.2 Disagreements Involving Separate Contractors.** If a disagreement arises among the Contractor and any Separate Contractors or

other forces permitted by the Owner to perform work at the Site over delays, impacts, inefficiencies, additional costs or damage to their work or property at the Site, the Contractor must, upon due notice to the Owner make a good faith effort to settle with such Separate Contractor. If a settlement is not reached, the Contractor must submit a Claim for an increase in the Contract Time and/or a Claim for an increase in the Contract Sum in accordance with Articles 11 and 12. If a Separate Contractor or other forces permitted by the Owner to perform work at the Site brings a claim under the Montgomery County Procurement Regulations against the Owner on account of any delay, impacts, inefficiencies, additional cost or damage alleged to have been caused by the Contractor, the Owner will notify the Contractor who must participate in such proceedings at the Contractor's expense. If any judgment or award against the Owner arises therefrom, the Contractor must indemnify the Owner from liability for any loss or damage and must reimburse the Owner for all fees and costs including attorney's, consultant's and expert's fees which the Owner has incurred in the defense and satisfaction of such claim, to the extent that the delay, impacts, inefficiencies, additional cost or damage is attributable to the acts, failures to act, or negligence of the Contractor or anyone for whom the Contractor is responsible.

## **ARTICLE 8**

### **PROTECTION OF PERSONS AND PROPERTY**

#### **8.1 RESPONSIBILITY FOR SAFETY**

**8.1.1 Responsibility for Site Safety.** The Contractor is responsible for initiating, maintaining and supervising all safety precautions and programs in connection with the performance of the Contract.

**8.1.2 Appointment of Safety Officer.** The Contractor must designate a responsible, properly trained and qualified member of the Contractor's organization who must maintain a full-time presence at the Site and whose duty is the prevention of accidents and the maintenance of safety programs, precautions and procedures. This person is the Contractor's Superintendent unless otherwise permitted or required by the Contract Documents, in which case the safety officer must be designated by the Contractor in writing to the Owner and Architect/Engineer.

**8.1.3 Compliance with Legal Requirements.** The Contractor must comply

with all applicable laws, ordinances, rules, regulations and lawful orders of public authorities bearing on safety of persons or property or their protection from damage, injury or loss.

#### **8.2 SAFETY OF PERSONS AND PROPERTY**

**8.2.1 Protections Required.** The Contractor must take reasonable precautions for the safety of, and must provide reasonable protection to prevent damage, injury or loss to:

- .1 All persons at and adjacent to the Site and other persons who may be affected by the Work or other operations of the Contractor;
- .2 The Work and materials and equipment to be incorporated therein or otherwise utilized in the performance of the Contract, whether in storage on or off the Site, under care, custody or control of the Contractor or the Contractor's Subcontractors or Sub-subcontractors; and
- .3 Other property at the Site or adjacent thereto and not designated for removal, relocation or replacement in the course of construction.

**8.2.2 Notices and Safeguards.** The Contractor must implement and maintain, as required by the Contract Documents, applicable laws and regulations and orders of public authorities having jurisdiction (including without limitation OSHA and MOSH), manufacturers' instructions or recommendations, existing conditions and performance of the Contract, reasonable safeguards for safety and protection, including issuing appropriate notices, distributing material safety data sheets and other hazard communication information, providing protective clothing and equipment, posting danger signs and other warnings against hazards, promulgating safety regulations and notifying owners and users of adjacent sites and utilities.

**8.2.3 Loading.** The Contractor must not load nor permit any part of any structure at the Site to be loaded or subjected to stresses or pressures so as to endanger its safety or that of adjacent structures or property.

**8.2.4 Hazardous Activities.** When explosives or other hazardous materials or equipment are stored or used or unusual methods are employed or hazardous conditions



are present in the performance of the Work, the Contractor must exercise utmost care and conduct such activities under supervision of properly qualified personnel.

**8.2.5 Qualified Personnel.** The Contractor must ensure that all work is performed by qualified personnel, trained in accordance with all applicable laws and regulations, to safely perform the work.

**8.2.6 Emergencies.** In an emergency affecting safety of persons or property, the Contractor must take all necessary action, without the necessity for any special instruction or authorization from the Owner or the Architect/Engineer, to prevent threatened damage, injury or loss. The Contractor must promptly but in all events within twenty-four (24) hours of the occurrence report such action in writing to the Owner and the Architect/Engineer. If the Contractor incurs additional costs on account of or is delayed by such action, the Contractor may file a Claim requesting a change in the Contract Time or Contract Sum to account for such action in accord with Articles 11 and 12. **Any such Claim must be filed within ten (10) days of the occurrence or it will be conclusively deemed to have been waived.** Any adjustment in the Contract Time or Contract Sum shall be limited to the extent that the emergency work is not attributable to the fault or neglect of the Contractor or otherwise the responsibility of the Contractor under the Contract Documents.

**8.2.7 Notice of Physical Injury or Damage.** If the Contractor suffers physical injury or damage to person or property because of an act or omission of the Owner, or of any of the Owner's employees or agents, or of others for whose acts it is contended that the Owner is liable, written notice of such injury or damage, whether or not insured, must be given to the Owner within a reasonable time not exceeding forty eight (48) hours after the onset or occurrence of such damage or injury or such shorter time as may be required by the Occupational Safety & Health Administration (OSHA). The notice must provide sufficient detail to enable the Owner to investigate the matter. **If notice is not received by the Owner within the time specified, any Claim arising from the occurrence will be deemed to be conclusively waived,** except to the extent of any applicable insurance (excluding self-insurance) coverage covering such occurrence. **The provisions of this subsection may not be used by the Contractor in lieu of the**

**requirements of Article 12 when the Contractor is seeking an adjustment in the Contract Sum and are in addition to the requirements of Article 11 when the Contractor is seeking an adjustment in the Contract Time.**

**8.2.8 Remedy of Property Damage.** The Contractor must promptly remedy damage and loss to property referred to in Subsections 8.2.1.2 and 8.2.1.3 caused in whole or in part by the Contractor, a Subcontractor, a Sub-subcontractor, a Supplier, or anyone directly or indirectly employed by any of them, or by anyone for whose acts they may be liable, unless otherwise instructed in writing by the Owner. This obligation is in addition to, and not in limitation of, the Contractor's obligations for indemnification under Section 8.4. The Contractor shall not be responsible for the security of materials, equipment and tools of Separate Contractors and other forces permitted by the Owner to perform work at the Site..

**8.2.9 Responsibility for Site Security.** The Contractor is responsible for taking all reasonable and necessary precautions to secure and protect the Site, the Work, materials and equipment to be incorporated therein, and any tools or equipment of the Contractor necessary or beneficial to the performance of the Work from damage due to vandalism, theft, arson, or other criminal mischief. The Contractor must repair and/or replace that portion of the Work and any materials or equipment to be incorporated therein and any tools or equipment of the Contractor necessary or beneficial to performance of the Work which are damaged or stolen due to vandalism, theft, arson, or any other criminal mischief at its expense whether or not covered by insurance. No increase of the Contract Time or increase in the Contract Sum will be granted to the Contractor as a consequence of any delay, impacts or inefficiencies resulting from any act of vandalism, theft, arson or other criminal mischief whether or not caused or contributed to by the Contractor's negligence. The Contractor is responsible for securing the Site against unlawful and unauthorized entry.

### **8.3 HAZARDOUS MATERIALS**

**8.3.1 Disclosure, Identification and Handling.** The Contractor must maintain at the Site, available to the Owner and the Architect/Engineer, appropriate information pertaining to all Hazardous Materials brought to the Site. Such materials must be properly

labeled or identified, and the Contractor must properly store, handle and use them at all times. Manufacturers and distributors are required by the federal Hazard Communication Standard (29 CFR §1910.1200), and the Maryland "Access to Information About Hazardous and Toxic Substances" law to label each Hazardous Material or chemical container, and to provide Material Safety Data sheets to the purchaser. The Contractor must comply with these laws and must provide the Owner and Architect/Engineer with copies of all relevant documents, including Material Safety Data sheets prior to performance of services or contemporaneous with delivery of goods. The Contractor must provide and designate appropriate and secure areas for their storage and must notify the Owner and Architect/Engineer of their presence and location at the Site. The Contractor must not store Hazardous Materials at the Site in excess of those reasonably needed for the Contractor's current operations, and must properly remove or dispose of all Hazardous Materials, including combustible waste, as soon as possible after completion of the operations in which they are utilized.

**8.3.2 Discovery of Hazardous Materials at the Site.** In the event the Contractor encounters on the Site material reasonably believed to be a Hazardous Material (other than those for which the Contractor may have specific responsibility for remediation under the Contract), and the Contractor's reasonable precautions will be inadequate to prevent foreseeable damage or injury and the Contractor cannot proceed with the Work in the absence of the removal, containment or remediation of the Hazardous Material, the Contractor must immediately stop Work in the area affected and report, within twenty four (24) hours the condition to the Owner and the Architect/Engineer in writing.

**8.3.3 Investigation and Remediation.** Upon receipt of notice of suspected Hazardous Materials, the Owner will cause an investigation to be made to verify the presence and extent of such materials, to determine whether such materials are in fact hazardous, and the steps necessary for their removal, containment or remediation.

**8.3.4 Resumption of Work.** If the Owner's investigation confirms the presence of Hazardous Materials which present a risk of injury or damage which will not be adequately protected against by the Contractor's reasonable precautions, then the Work in the affected area must not thereafter be resumed except at the

written direction of the Owner. The Work in the affected area will be resumed promptly (i) in the absence of a finding of Hazardous Material by the Owner, (ii) upon the removal, containment or remediation of the Hazardous Materials, or (iii) upon the establishment of appropriate safety precautions.

**8.3.5 Adjustments for Hazardous Materials.** The Contractor may request a change in the Contract Time or Contract Sum if the Contractor incurs additional costs on account of or is delayed by the need to remove, contain or remediate Hazardous Materials which has not been rendered harmless at the Site unless the Contractor is responsible for same under the Contract. Any such requested change in the Contract Time or Contract Sum must be made in within ten (10) days of the Owner's approved resumption of Work referenced in Subsection 8.3.4 and must fully comply with Articles 11 and 12 or any Claim will be deemed conclusively waived by the Contractor.

## **8.4 INDEMNIFICATION**

**8.4.1 Indemnity and Duty to Defend.** The Contractor shall defend, indemnify and hold harmless the Owner, its consultants and Separate Contractors, the Architect/Engineer, the Architect/Engineer's consultants, and any of their Subcontractors, Sub-subcontractor, Suppliers, agents and employees from and against liability for all claims, damages, (including incidental and consequential), losses (including purely economic losses) and expenses, including but not limited to attorneys', expert witnesses' and consultants' fees, which arise out of or result from (a) the performance of the Work, (b) operations at the Site or (c) any act or omission by the Contractor. Such performance, operations, acts or omissions of the Contractor include the performance, operations, acts or omissions of the Contractor's Subcontractors, sub-subcontractors, Suppliers and their respective agents and employees and anyone for whose acts said parties may be liable. This indemnity obligation and the duty to defend applies, regardless of whether or not such claim, damage, loss or expense is also caused or is alleged to have been caused in part by the negligence or act or omission of a party indemnified hereunder, provided it is also caused or alleged to have been caused at least in part by the Contractor, a Subcontractor, Sub-subcontractor, Supplier or their agents or anyone directly or indirectly employed by them or anyone for whose acts said parties may be liable. The duty to defend accrues at the time a

claim that potentially is within the scope of coverage of the indemnity herein is made against the indemnitee(s). For purposes of this Subsection 8.4.1, the term Owner includes its boards, agencies, agents, officials and employees.

**8.4.2 Effect of Limitations on Statutory Benefits.** In claims against any indemnitee hereunder by an employee of the Contractor, a Subcontractor, Sub-subcontractor or Supplier or anyone directly or indirectly employed by them or anyone for whose acts said parties may be liable, the indemnification obligation and duty to defend under Subsection 8.4.1 are not limited by the amount or type of damages, compensation or benefits payable by or for the Contractor or a Subcontractor, Sub-subcontractor or Supplier under workers' or workmen's compensation acts, disability benefit acts or other employee benefit acts.

**8.4.3 Limitation as to Negligence of Indemnitee(s).** The Contractor's obligations under Subsection 8.4.1 to indemnify (but not the duty to defend which shall apply nonetheless) do not apply to the extent that, but only to the extent that, any claim, damage, loss or expense as to bodily injury to any person or damage to property (but not as to purely economic claims, damages, losses or expenses as to which the Contractor's obligation under Subsection 8.4.1 shall nonetheless apply) is ultimately determined to result from the sole and exclusive negligence of the indemnitee(s).

**8.4.4 Other Rights of Indemnity.** The indemnification obligations of this Section 8.4 must not be construed to negate, abridge, or reduce any common-law or statutory rights of the indemnitee(s) which would otherwise exist as to such indemnitee(s).

## **ARTICLE 9**

### **SUBMITTALS**

#### **9.1 SUBMITTALS REQUIRED**

**9.1.1 Precontract Submittals.** The Owner reserves the right to require certain Submittals before executing the Contract. Submittals required before execution of the Contract include, but are not limited to, the following:

- .1 Performance and Payment Bonds acceptable to the Owner as provided in Subsection 17.1;
- .2 Policies and certificates of insurance acceptable to the Owner as provided in Subsections 17.2.7 and 17.3.9; and

- .3 Other submittals required by the Bid or RFP Documents.

**9.1.2 Initial Submittals.** Unless otherwise provided in the Bid or RFP Documents or the Contract Documents, Submittals required within the first thirty (30) days (or such shorter period as specified in the following sections) after issuance of a Notice to Proceed include, but are not limited to, the following:

- .1 A Progress Schedule for approval by the Architect/Engineer and the Owner as provided in Subsection 11.2.1 which must be provided within fifteen (15) days of the Notice to Proceed;
- .2 A Schedule of Submittals including Shop Drawings, Product Data Samples and other Submittals for approval by the Architect/Engineer as provided in Subsection 11.2.6;
- .3 A list of Subcontractors and Suppliers as provided in Subsection 6.1.1 which must be provided within ten (10) days of the Notice to Proceed;
- .4 A list of Contractor's key personnel as provided in Subsection 5.4.2;
- .5 A Schedule of Values as provided in Subsection 13.1.1 which must be provided within ten (10) days of the Notice to Proceed;
- .6 A construction quality control (CQC) plan as provided in the Specifications, if applicable; and
- .7 Other Submittals required by the Contract Documents.

**9.1.3 Submittals During Construction.** Unless otherwise provided in the Contract Documents, Submittals required during the course of construction include, but are not limited to, the following:

- .1 A certified building location survey as provided in Subsection 14.3.3.7;
- .2 [This subsection intentionally not used];
- .3 Progress reports (regular and intermittent) as provided in the Specifications, properly identified and authenticated;
- .4 Certificates of inspection, approval and test reports as provided in Subsection 10.5.7;



- .5 Monthly Progress Schedules as provided in Subsection 11.2.5 and Section 9 (G) of the Contract;
- .6 Applications for Payment with supporting documentation as provided in Section 13.2; and
- .7 Shop Drawings, Product Data Samples and other Submittals required by the Contract Documents.

**9.1.4 Closing Submittals.** Unless otherwise provided in the Contract Documents, Submittals required upon Substantial and Final Completion of the Work include those described in Subsections 14.2.2 and 14.3.3.

**9.1.5 Purpose of Submittals.** Submittals required by the Contract Documents are not Contract Documents. The purpose of their submission is to demonstrate, for those operations or portions of the Work for which Submittals are required, the way the Contractor proposes to conform to the information given and the design concept expressed in the Contract Documents, or otherwise to demonstrate the Contractor's compliance with the requirements of the Contract Documents. Review of Submittals is subject to the limitations of Subsection 9.2.7.

**9.1.6 Performance of Work.** The Contractor must not perform any portion of the Work requiring submission, review or approval of Submittals until the respective Submittal has been submitted and any required approval has been given. Such Work must be in accordance with approved Submittals and the Contract Documents. In the event of a conflict between an approved Submittal and the Contract Documents, the requirements of the Contract Documents shall control over the approved Submittal. The Contractor must correct at its cost, and without any adjustment in Contract Time, any Work the correction of which is required due to the Contractor's failure to obtain approval of a Submittal required to have been obtained prior to proceeding with the Work, including, but not limited to, correction of any conflicts in the Work resulting from such failure.

## **9.2 SUBMISSION, REVIEW AND APPROVAL OF SUBMITTALS**

**9.2.1 Contractor's Submission.** The Contractor must prepare and submit to the Architect/Engineer Submittals required by the Contract Documents with reasonable promptness and in such sequence as to cause no delay in the Work or in the activities of the

Owner or of Separate Contractors or other forces permitted to perform work at the Site. The Contractor must submit them in accordance with the Schedule of Submittals provided under Subsection 11.2.6. The Contractor must provide the Owner and the Architect/Engineer with copies of all Submittals made to regulatory agencies.

**9.2.2 Verification of Information in Submittals.** By submitting Shop Drawings, Product Data, Samples and similar Submittals, the Contractor represents that the Contractor has determined and verified materials, field measurements and field construction criteria related thereto and has checked and coordinated the information contained within such Submittals with the requirements of the Work and of the Contract Documents. All Submittals must bear the following certification, signed and dated by the Contractor, and by any Subcontractor, Sub-subcontractor or Supplier who has prepared the Submittal for the Contractor:

*"I certify that the requirements of the Contract Documents have been met and all dimensions, conditions and quantities are verified as shown on the attached Submittal."*

The foregoing certification will be deemed to have been inserted into any Submittal from which it has been omitted.

**9.2.3 Identification of Submittals.** All Submittals, including Shop Drawings and Samples, must include submittal tracking numbers coinciding with the Specification section and Submittal log and must be dated and marked to show the names of the Project, Architect/Engineer, Contractor, originating Subcontractor, Sub-subcontractor, manufacturer or Supplier, and separate detailer if pertinent. Shop Drawings must completely identify Specification section and locations at which materials or equipment are to be installed. Reproductions of Contract Drawings are acceptable as Shop Drawings only when specifically authorized in writing by the Architect/Engineer. Submittals must be submitted under cover of a Submittal form approved by the Owner which must include at a minimum the information required in this subsection, the identity of each recipient of the Submittal, and such other information as the Owner may require.

**9.2.4 Deviations from Contract Requirements.** At the time of submission, the Contractor must specifically note in the

transmittal form any deviations in the Submittal from the requirements of the Contract Documents. No such deviation will be considered as having been approved solely by reason of approval of a Submittal in which the deviation was noted; instead, if the Contractor is seeking approval of the deviation from the Contract Documents, the Contractor must comply with the provisions of Section 12.6 governing approval of Or-Equal items or Substitutions, as applicable.

**9.2.5 Return Without Action.** Incomplete Submittals will be returned to the Contractor without action and must be promptly completed and resubmitted by the Contractor. Submittals made by the Contractor which are not required by the Contract Documents may be returned without action.

**9.2.6 Review and Action by Architect/Engineer.** The Architect/Engineer or the Owner, or both as appropriate for the type of Submittal, will review and approve or take other appropriate action upon the Contractor's Submittals. Such action will be taken with such reasonable promptness as to cause no unreasonable delay in the Work, provided that Contractor has acted promptly in submitting, correcting and resubmitting such Submittals and sufficient time has been allowed to permit adequate review. A minimum of thirty (30) Days for review must be allowed, unless otherwise agreed to in writing by the Architect/Engineer.

**9.2.7 Scope of Review.** Review of Submittals will be only for the limited purpose of checking for conformance with the design concept expressed in and the specific requirements of the Contract Documents. Review of such Submittals is not conducted for the purpose of determining their accuracy and completeness, reviewing the means and methods of fabrication or assembly, confirming details such as dimensions and quantities, or for substantiating instructions for installation or performance of equipment or systems, all of which remain the responsibility of the Contractor in accordance with the Contract Documents.

**9.2.8 Correction and Resubmission.** The Contractor must submit additional information or make any corrections required and must resubmit the required number of corrected copies of Submittals for further review and approval or other appropriate action required by the Contract Documents until such approval or other action is taken. No delay will be recognized, and no increase of Contract Time

will be given, for any delay in approval of Submittals which results from returning Submittals to the Contractor for incompleteness, correction and resubmission. If more than two (1) resubmittals are required the Contractor must pay any amounts the Owner owes the Architect for review of further resubmittals.

**9.2.9 Identification of Revisions.** The Contractor must direct specific attention, in writing or on resubmitted Submittals, to any revisions made in a resubmitted Submittal other than those requested by the Owner or the Architect/Engineer on previous Submittals. No such revision will be considered as having been approved solely by reason of approval of a Submittal in which the revision was noted.

**9.2.10 Responsibility for Deviations, Revisions, Errors and Omissions in Submittals.** Approval of any Submittal will not extend to, and the Contractor will not be relieved of responsibility for, (i) deviations or revisions not specifically identified and approved in accordance with Subsections 9.2.4 or 9.2.9, or (ii) any errors or omissions in Submittals, except to the extent such errors or omissions occur in the Contract Documents and are the responsibility of the Architect/Engineer and/or Owner. Review and approval of the Contractor's Submittals by the Owner and/or the Architect/Engineer will not relieve the Contractor of its obligations under the Contract, nor will it constitute approval of safety precautions or of any construction means, methods, techniques, sequences or procedures of fabrication or assembly. The approval of a specific item does not indicate approval of an assembly of which the item is a component.

**9.2.11 Professional Certifications.** The Contractor must provide professional certifications on submittals and shop drawings as required by the Contract Documents. The Owner and the Architect/Engineer are entitled to rely on the accuracy and completeness of professional certifications of performance criteria of materials, systems or equipment required by the Contract Documents.

**9.2.12 Submittals for Finishes.** The Architect/Engineer may postpone review of Submittals requiring color or finish selections until such time as all such Submittals have been submitted. Any delays and/or extra costs resulting from incomplete Submittals are the responsibility of the Contractor.

---

## **ARTICLE 10**

---

### **QUALITY CONTROL PLAN,**

## **COMMISSIONING REPORT AND WARRANTIES**

### **10.1 QUALITY CONTROL PLAN AND COMMISSIONING REPORT**

**10.1.1 Quality Control Plan.** Unless noted otherwise in the Contract Documents, the Contractor must prepare and submit a quality control plan in accordance with the requirements of the Contract Documents for review and approval by the Owner within thirty (30) days of Notice to Proceed. The Contractor must comply with the requirements of the approved quality control plan.

**10.1.2 Commissioning Plan.** Unless noted otherwise in the Contract Documents, the Owner will provide a commissioning plan to the Contractor; the Contractor must comply with the requirements of the Owner's commissioning plan. If noted in the Contract Documents, the Contractor must prepare and submit a commissioning plan in accordance with the requirements of the Contract Documents for review and approval by the Owner. The Contractor must comply with the requirements of the approved commissioning plan.

### **10.2 GENERAL WARRANTY AND SPECIAL WARRANTIES**

**10.2.1 General Warranty.** The Contractor warrants to the Owner that all materials and equipment furnished under the Contract will be of first quality and new unless otherwise required or permitted by the Contract Documents, that the Work will be free from defects, and that the Work will conform to the requirements of the Contract Documents.

**10.2.2 Duration of General Warranty.** The Contractor warrants and guarantees for one (1) year from Substantial Completion, or for a longer period that is otherwise expressly stated in the Contract Documents, the Work. This includes a Warranty and Guarantee against any and all defects for a minimum period of one (1) year from Substantial Completion or any longer period stated in the Contract Documents. The Contractor must correct any and all defects in material and/or workmanship which may appear during the Warranty and Guarantee period, by repairing (or replacing with new items or new materials, if necessary) any such defect at no cost to the Owner, within a reasonable period of time, and to the Owner's satisfaction.

**10.2.3 Relation to Specific Correction Provisions and Other Remedies.** The Contractor's general warranty and any additional

or special warranties are not limited by the Contractor's obligations to specifically correct defective or nonconforming Work as provided in Section 10.6, nor are they limited by any other remedies provided in the Contract Documents. The Contractor shall also be liable for any damage to property or persons (including death) including consequential and direct damages relating to any breach of the Contractor's general warranty or any additional or special warranties required by the Contract Documents.

**10.2.4 Additional or Special Warranties.** The Contractor must furnish all special warranties required by the Contract Documents no later than Substantial Completion. The Owner may require additional special warranties in connection with the approval of "Or-Equals" or Substitutions, Allowance items, Work which is defective or nonconforming, or the acceptance of nonconforming Work pursuant to Subsection 10.6.3.

### **10.3 OBSERVATION AND INSPECTION OF WORK**

**10.3.1 Access to Work.** The Contractor must provide the Owner and the Architect/Engineer safe access to the Work at all times that it is in preparation or progress wherever located.

**10.3.2 Site Visits.** The Owner, its Construction Representatives, its consultants and the Architect/Engineer may visit the Site at intervals appropriate to the stage of construction to conduct progress meetings, to make observations and inspections and to become generally familiar with the progress and quality of the completed Work, and to determine in general if the Work is being performed in a manner indicating that the Work, when completed, will be in accordance with the Contract Documents.

**10.3.3 Responsibility of Contractor.** Neither the observations of Owner or the Architect/Engineer nor the performance of any inspections, tests or approvals relieves the Contractor from its obligations to perform the Work in accordance with the Contract Documents.

### **10.4 UNCOVERING OF WORK**

**10.4.1 Uncovering of Prematurely Covered Work.** If a portion of the Work is covered contrary to the request of the Owner or its designee or the Architect/Engineer, or to specific requirements of the Contract Documents, or prior to any required inspection or testing, the Owner or its designee or the Architect/Engineer

may require that the covered Work be uncovered by the Contractor for observation, inspection, testing or approval as appropriate. Any Work that is damaged or removed by such uncovering must be replaced at the Contractor's expense and without change in the Contract Time.

#### **10.4.2 Uncovering of Other Covered Work.**

If a portion of the Work has been covered which is not required by the Contract Documents or any other requirement to remain uncovered, or which the Owner or its designee or the Architect/Engineer has not specifically requested to observe, test, inspect or approve prior to its being covered, the Owner or its designee or the Architect/Engineer, with the Owner's concurrence, may require that such Work be uncovered by the Contractor. If such Work is in accordance with the Contract Documents, a Change Order will be issued to account for the cost of uncovering and replacement (if a Change Order is not issued, the Contractor must file a Claim for adjustment of the Contract Sum within the time and containing the information required in Article 12 or the same will be deemed to be conclusively waived), and if it affects activities on the critical path, the Contractor may file a Claim requesting an adjustment in the Contract Time (if a Change Order is not issued, the Contractor must file a Claim requesting an adjustment of the Contract Time within the time and containing the information required in Article 11 or the same will be deemed to be conclusively waived). If such Work is not in accordance with the Contract Documents or any other requirement, the Contractor must bear the costs and time impacts of uncovering, testing, inspection, specific approval, correction and replacement, including the additional costs of the Owner's and the Architect/Engineer's services and all delays relating thereto.

### **10.5 TESTS, INSPECTIONS AND APPROVALS BY OTHERS**

**10.5.1 Required Tests, Inspections and Approvals.** The Contractor must arrange for tests, inspections and approvals of portions of the Work required by the Contract Documents, laws, ordinances, rules, regulations or orders of public authorities having jurisdiction, or the Owner or its designee acting as a public authority, to be made at an appropriate time. Unless otherwise provided in the Contract Documents, such tests, inspections and approvals, other than those provided by public authorities, must be provided by an independent

testing laboratory or entity acceptable to the Owner, and the Contractor must bear all related costs of tests, inspections and approvals. The Contractor must give the Owner, through the Architect/Engineer, timely notice of when and where tests and inspections are to be made so the Owner and the Architect/Engineer may observe such procedures.

**10.5.2 Tests and Inspections by Owner.** If indicated in the Contract Documents, the Owner will hire, and pay the costs for, inspection and testing agencies for specific portions of the Work. The Contractor must coordinate with any Owner-hired inspection and testing agencies and arrange for (schedule) tests, inspections and approvals of portions of the Work required by the Contract Documents without delaying the Work.

- .1 Notice of Problems with Owner-hired Inspection Agencies.** The Contractor shall promptly notify the Owner of any problems or concerns with Owner-hired inspection and testing agencies.
- .2 Mis-scheduling of Owner-hired Inspection Agencies.** The Contractor is responsible for coordinating and accurately scheduling Owner-hired inspection and testing agencies so that the work is ready for inspection when scheduled with the agencies. The Contractor's failure to accurately schedule inspections and/or tests with the Owner-hired agencies causes the Owner unnecessary costs. If the Contractor repeatedly fails to accurately schedule the inspections/testing agencies' time, the Owner will backcharge the Contractor for the cost of the unnecessary Site visits by the Owner-hired agencies.

**10.5.3 Scheduling of Tests, Inspections and Approvals.** The Contractor must schedule all tests, inspections or specific approvals required by law or the Contract Documents so as to avoid any delay in the Work.

**10.5.4 Additional Tests, Inspections and Specific Approvals.** The Owner may, in its discretion, require the Contractor to perform additional testing, or obtain inspection or specific approval of any portion of the Work, whether or not such Work is fabricated, installed or completed. However, neither a recommendation made by the Architect/Engineer nor a decision

by the Owner either to require or not to require such testing, inspection or specific approval gives rise to a duty or responsibility of the Owner or the Architect/Engineer to the Contractor, Subcontractors, Sub-subcontractors, material and equipment Suppliers, their agents or employees, or other persons performing portions of the Work.

**10.5.5 Other Tests, Inspections and Specific Approvals Required by Owner.** In addition to the tests required by this Section 10.5, the Owner may at any time arrange for other tests, inspections and specific approvals to be performed by others selected by the Owner, at the Owner's expense. The Contractor must cooperate with the Owner and provide access to the Work for such tests, inspections and approvals.

**10.5.6 Notice to Contractor.** If the Owner, in its discretion, determines that portions of the Work require additional testing, inspection or approval not included under Subsection 10.5.1, the Owner or the Architect/Engineer will instruct the Contractor to make arrangements for such additional testing, inspection or approval, and the Contractor must give timely notice to the Owner and the Architect/Engineer of when and where tests and inspections are to be made so the Owner and the Architect/Engineer may observe such procedures. Unless otherwise provided, additional testing, inspection and approval must be conducted by an organization selected by the Contractor that is acceptable to the Owner. The Owner shall bear such costs except as provided in Subsections 10.5.9 and 10.6.2.

**10.5.7 Observation of Tests, Inspections or Approvals.** If the Owner or the Architect/Engineer is to observe tests, inspections or approvals, they will do so, so as not to delay any critical path activities and, where practicable, at the normal place of testing, provided reasonable notice of them has been given by the Contractor to the Owner and Architect/Engineer.

**10.5.8 Certificates of Testing, Inspection and Approval.** Required certificates of testing, inspection or approval must, unless otherwise required by the Contract Documents, be secured by the Contractor and promptly delivered to the Architect/Engineer for the Owner.

**10.5.9 Costs of Re-Testing, Inspection and Approval.** If testing, inspection or approval under Subsections 10.5.1, 10.5.3 or 10.5.4 reveals failure of any portion of the Work to

comply with the Contract Documents or applicable legal requirements, the Contractor must bear all costs and time impacts made necessary by such failure, including costs of the Owner's and Architect/Engineer's additional services and expenses and the costs of repeated testing, inspection or approval, and Contractor's cost to correct.

## **10.6 REJECTION AND CORRECTION OF WORK**

**10.6.1 Rejection of Nonconforming Work.** The Owner and the Architect/Engineer may reject Work at any time that does not conform to the Contract Documents. Unless the Contractor is specifically instructed otherwise, any Work that fails a required test, inspection or approval will be considered as having been rejected, whether or not specific notice of rejection is given by the Owner or the Architect/Engineer.

**10.6.2 Contractor to Correct or Replace Rejected Work.** The Contractor must promptly correct or, at the Owner's option, replace Work which is rejected by the Owner or the Architect/Engineer as defective or which otherwise fails to conform to the requirements of the Contract Documents, whether before or after Substantial Completion. The Owner may require additional testing or inspection of such Work as provided in Subsection 10.5.3. The Contractor must bear the costs and any time impact related to correcting or replacing such rejected Work, including costs of the Owner's and the Architect/Engineer's additional services and expenses and the costs of additional or repeated testing, inspection or approval and all delays relating thereto.

**10.6.3 Acceptance of Defective or Nonconforming Work.** If the Owner determines that it is in its best interests to accept Work which is not in accordance with the requirements of the Contract Documents instead of requiring its correction or replacement, the Owner may accept such Work with an appropriate corresponding adjustment reducing the Contract Sum and, if appropriate, the Contract Time. Any such acceptance of defective or nonconforming Work will not extend to defects or deficiencies not expressly revealed to the Owner in writing at the time of acceptance. Any such acceptance to be effective must be in writing and signed by the Director.

**10.6.4 Removal of Defective or Nonconforming Work.** The Contractor must promptly remove from the Site and dispose of any materials, supplies or equipment that does



not comply with the requirements of the Contract Documents and/or which has been rejected by the Owner.

**10.6.5 Contractor to Bear Cost to Correct or Replace Other Work.** The Contractor must bear the cost and any time impact related to correcting or replacing any construction of the Owner or Separate Contractors or other forces permitted to perform work at the Site which is destroyed or damaged by the Contractor's correction, removal or replacement of Work that does not comply with the requirements of the Contract Documents.

**10.6.6 Failure to Correct or Replace.** If the Contractor fails to correct or replace Work that is rejected, defective or nonconforming within a reasonable time as required by the Owner, the Owner may correct or replace it. The Owner may remove and dispose of, or at its discretion, store for subsequent auction or private sale, the remaining materials or equipment. All costs of correction, removal, replacement, disposal, storage or sale, including costs of the Owner's and the Architect/Engineer's additional services, must be borne by the Contractor and may be backcharged by the Owner against the Contract Sum.

**10.6.7 Artistic Decisions.** The Owner's decisions in matters relating to artistic effect are final.

## **10.7 SPECIFIC CORRECTION OF WORK**

**10.7.1 Specific Correction Period.** Unless otherwise provided in the Contract Documents for a particular item or class of Work, and in addition to any other warranty provided in this Contract, the Contractor must correct or replace any Work found to be defective, non-complying or nonconforming, or any Work (whether by the Contractor or by others) affected thereby, discovered during the specific correction periods as follows:

- .1 Within one year after the Date of Substantial Completion of the Work or designated portion thereof;
- .2 Where the Owner takes partial occupancy or use, one year after the date for commencement of warranties established under Subsection 14.1.5;
- .3 The period of time, if any, established by terms of an applicable special warranty required by the Contract Documents; or

- .4 In the case of hidden or latent defects discovered within the period established by the applicable statute of limitations, a period of one year from the date that the Owner discovers, or should reasonably have discovered, the defect, noncompliance or nonconformance.

**10.7.2 Specific Correction Required.** If, within the applicable specific correction period provided in Subsection 10.7.1, any of the Work does not comply with the requirements of the Contract Documents, the Contractor must correct or, at the Owner's sole option, replace it promptly after receipt of written notice from the Owner to do so, unless the Owner elects to accept such Work in accordance with Subsection 10.6.3.

**10.7.3 Notice and Demand for Specific Correction Obligation.** The Owner will give notice to the Contractor within a reasonable time after discovery of Work which it believes to be subject to specific correction. The Owner will afford the Contractor an opportunity to jointly inspect the Work within a reasonable time after such notice, and will, at the Contractor's request, arrange for the Architect/Engineer's presence at such inspection. If no agreement is reached between the Owner and Contractor as to the responsibility and steps to be taken for correction, the Owner may issue a demand for correction to the Contractor, who must comply promptly with the demand. Failure to comply with such demand constitutes a material breach of the Contract. **Any Claim for an increase in the Contract Time and/or a Claim for an increase in the Contract Sum with respect to such demand for correction must be filed by the Contractor in accordance with Articles 11 and/or 12 or the same will be deemed to have been conclusively waived.**

**10.7.4 Extension of Specific Correction Obligation.** If the Work remains uncorrected, or if the Work has exhibited a pattern of repeated failure requiring repeated correction, the applicable specific correction period will recommence in its entirety upon the completion of the latest specific correction period.

**10.7.5 Inspection Prior to Warranty Expiration.** Thirty (30) days prior to the expiration of the correction period provided for in Subsection 10.7.1, the Contractor must conduct a joint inspection of the Work with the Owner and the A/E to determine whether any additional items remain to be corrected.

**10.7.6 Effect on Other Remedies.** Nothing contained in this Section 10.7 is to be construed to establish a period of limitation with respect to other obligations which the Contractor might have under the Contract Documents. This Section relates only to the specific obligation of the Contractor to correct or replace the Work, and has no relationship to the time within which the Contractor's obligations under the Contract Documents may be sought to be enforced, nor to the time within which proceedings may be commenced to establish the Contractor's liability with respect to the Contractor's obligations other than specifically to correct or replace the Work. In addition, the Contractor shall also be liable for any damage to property or persons (including death) including consequential and direct damages relating to any defective Work or Work which fails to conform to the requirements of the Contract Documents.

## **ARTICLE 11**

### **TIME**

#### **11.1 COMMENCEMENT**

**11.1.1 Date of Commencement and Notice to Proceed.** The Owner will issue a Notice to Proceed and make the Site available to the Contractor within a reasonable time after execution of the Contract. The date on which the Contract Time commences, as established in the Notice to Proceed, will not be postponed by failure to proceed with the Work by the Contractor or persons or entities for whom the Contractor is responsible. For phased work noted in the Contract Documents, multiple Notices to Proceed may be issued by the Owner.

**11.1.2 Preconstruction Conference.** Promptly after the Notice to Proceed has been issued but before the Work at the Site begins, the Owner will conduct a preconstruction conference with the Contractor and any Separate Contractors to review Project requirements including, but not limited to, preliminary Submittals, schedules, Site utilization, construction operations to occur at the Site during the succeeding sixty (60) days, communications, coordination with Separate Contractors, payment procedures, and other matters.

**11.1.3 Commencement of Work at the Site.** The Contractor must not commence operations on the Site prior to issuance of the Notice to Proceed.

#### **11.2 CONSTRUCTION SCHEDULES**

**11.2.1 Contractor's Initial Progress Schedule.** Within fifteen (15) days after issuance of the Notice to Proceed, the Contractor must prepare and submit for the Owner's and Architect/Engineer's approval a proposed Initial Critical Path Method Project Schedule (ICPM) for performance of the Work, which schedule may be a cost and man-loaded Progress Schedule, if so specified in the Contract Documents. The Contractor will not receive any payments until such time the ICPM has been submitted and approved by the Owner. The schedule must (i) conform to all specified time limits, including Substantial, Final and any interim Completion dates, established by the Contract Documents, (ii) include all Work for each element of the Project as required by the Contract Documents, (iii) include the schedule for all Submittals, (iv) include all testing, inspections and commissioning required by the Contract Documents, and (v) provide for expeditious and practicable execution and completion of the Work within the Contract Time.

**11.2.2 Requirements of the Progress Schedule.** The ICPM must further comply with the scheduling specifications set forth in the Contract Documents, and to the extent not inconsistent therewith, must also fully comply with the following requirements.

The Contractor must plan, schedule, and construct the Work using a Critical Path Method Project Schedule (CPM). The CPM must be used for coordinating and monitoring all the work specified in the Contract Documents including all activities of Subcontractors, Sub-subcontractors, vendors, Suppliers, utilities, the Owner, Separate Contractors, authorities having jurisdiction, and all other parties associated with the construction of the Contract. All work including but not limited to submittals, major procurement, delivery, and construction activities must be included. All activities specified in the Contract Documents must be included in the CPM. The CPM must be based upon the entirety of the Contract Documents. **The software utilized for the CPM must generate files that are compatible with Primavera Project Planner.**

**Float.** The CPM utilizes float. Float is defined as the amount of time between when an activity "can start to finish" and when an activity "must start or finish". Float is a shared commodity for the use of the Owner and the Contractor and is not for the exclusive use or benefit of either party. The parties have the full use of the float



until it is depleted.

**Scheduling Representative.** The Contractor must designate a scheduling representative, prior to submission of the Initial Critical Path Method Project Schedule (ICPM). The scheduling representative is the person primarily responsible for development and maintenance of the Contractor's CPM schedule. The scheduling representative will represent the Contractor in all matters regarding the schedule and must attend all schedule related meetings.

The Contractor must submit the qualifications of the designated scheduling representative to the Owner for approval within ten (10) days of Notice-to-Proceed. This approval is required before the ICPM will be accepted. The designated scheduling representative must have at least three years of verifiable experience in preparing and maintaining CPM project schedules on contracts of similar size and complexity. Replacement of the scheduling representative by the Contractor will require written approval from the Owner.

**Initial Critical Path Method Project Schedule (ICPM).** The ICPM must consist of:

- (a) A time scaled diagram. The ICPM time scaled diagram will have a scale and format that is acceptable to the Owner and Architect/Engineer. The activities must be labeled with the activity identification clearly shown for each activity. All relationships between activities must be shown;
- (b) Tabular reports with activities sorted as follows:
  - (1) Activity ID. This report must include predecessors and successors for each activity with leads and lags shown;
  - (2) Activity ID. This report must include resources. This report must clearly define the resources assigned to each activity.
  - (3) Early Start, Total Float;

- (4) Total Float, Early Start;
- (5) Project Area (if applicable);
- (6) Project Phase (if applicable); and
- (7) Responsibility e.g., Contractor, specific subcontractor, specific supplier, the Owner, utilities and specific third parties.

The header of each tabular report must include the project name, Contract number, data date, run date and number, and report type.

The body of each report must include the activity identification, activity description, original and remaining duration, early/late start and finish dates, percent complete, actual start/finish dates, total float, and calendar designation for every activity.

- (c) Written Narrative (WN). The WN must comply with the requirements described hereinafter;
- (d) Printed Calendars. The printed calendars must include a listing, description, and calendar form tabulation of all calendars used in the ICPM. The calendar must contain the total number of anticipated work days (including day and night shifts) required to complete all the work required in the Contract. The calendars must delineate the holidays and anticipated non-work days or periods including inclement weather days. An explanation of the Contractor's basis for determining each non-work day

or period must be included in the WN; and

- (e) Data disc containing all of the information contained in the CPM. The format must be compatible with Primavera Project Planner software.

All construction activities must have durations not exceeding 10 working days, unless otherwise approved by the Owner and Architect/Engineer. Activities for review and approval of Submittals and shop drawings by the Architect/Engineer must be given durations of not less than 30 calendar days. The Contractor may submit a short list of highly critical approval activities to the Architect/Engineer. The Architect/Engineer will make every effort to expedite the approval of these Submittals; however, this will not alter the requirements to include 30 calendar days for all approvals in the ICPM. Durations for other procurement activities will be evaluated on a case by case basis.

The latest calculated early finish date in the ICPM shall equal the Contract calendar date for Substantial Completion specified in the Contract Documents. If the Contractor submits an earlier Substantial Completion date than specified in the Contract Documents, the Owner, upon approval of the ICPM, may issue a Change Order to adjust the Substantial Completion date to that shown on the ICPM.

For all Contracts with a Contract Sum exceeding eight million dollars (\$8,000,000), the Contractor must resource load all construction activities in its schedule and schedule updates with the material, equipment, and manpower planned to be utilized by the Contractor and its subcontractor in accomplishing each activity. Resource loading of the CPM must be fully explained in the WN.

The Owner and/or Architect/Engineer reserve the right to require specific activities and/or milestones to be added to the CPM (consistent with the Work).

The Contractor must utilize activity codes to categorize activities by at least the following: project area; project phase; and responsibility, e.g. Contactor or specific subcontractors.

The Contractor must provide a WN as part of the ICPM. This WN must explain the sequence of work, the critical path, interim completion dates, project phasing, non-work days, or periods, and labor and equipment resources (as appropriate). In addition, the Contractor must explain how the ICPM has provided for: permit requirements, environmental requirements, coordination with other public Contractors, milestone dates (for the Contract or other related contracts), coordination with other entities, coordination with all utility companies, special non-work days or periods, and weather in its ICPM. The WN must explain the specific scope of each critical activity and the basis used to determine the original duration of each activity, i.e., production rate and anticipated quantities.

All Work specified in the Contract Documents must be addressed in the WN. The Contractor shall utilize the WN to explain the following:

- (a) Relationships between activities not obviously identified;
- (b) Equipment usage and limitations;
- (c) Manpower usage and limitations;
- (d) Activity codes, abbreviations, and activity identification system;
- (e) All Calendars and how they are utilized in the CPM;
- (f) Date or time constraints;
- (g) All abbreviations in the ICPM; and

- (h) Scheduling of weather and temperature sensitive activities.

The Contractor must complete and submit the proposed ICPM within 15 calendar days after issuance of the Notice to Proceed; submission to the Architect/Engineer and Owner for review and approval shall include: one electronic copy and two paper sets (in color) to the A/E, and one electronic copy and three paper sets (in color) to the Owner.

The Architect/Engineer and Owner will complete the review of the Contractor's ICPM within 30 calendar days after the submittal. If required, the Architect/Engineer may convene a Joint Review Conference at which the Architect/Engineer, Owner and Contractor (including its scheduling representative) will make corrections and adjustments to the proposed ICPM. If a revision is necessary due to the Owner's or Architect/Engineer's review or the Joint Review Conference, the proposed revision must be submitted by the Contractor within seven calendar days after the Contractor received the Owner's and/or Architect/Engineer's review comments or within seven calendar days after the date of the Joint Review Conference, whichever is the latest. Revisions must conform to the requirements for the ICPM. The Owner and Architect/Engineer will respond to the revised ICPM within seven calendar days after the revised ICPM is received.

**Any delay in starting work caused by the acceptance of the ICPM by the Owner or Architect/Engineer will not be considered as a basis for any adjustments in the Contract Time or Contract Sum.**

When the Owner notifies the Contractor that the ICPM has been accepted, that document will become the CPM schedule of record. The Contractor will be responsible for implementing and executing the work specified in the Contract in strict conformance with the CPM Schedule of Record. The CPM Schedule of Record will be the

Contractor's work plan for completing the entire Contract as specified in the Contract Documents.

**CPM Updates.** The Contractor must update the CPM Schedule of Record and submit to the Owner and A/E for review on a monthly basis and at more frequent intervals as required by the issuance of Change Orders and Field Orders or other conditions of the Work and Project and as provided in Article 9 (G) of the Contract. The monthly updates of the CPM Schedule of Record are required to be submitted concurrent with the Contractor's monthly Application for Payment; however, the CPM update is required whether the Contractor submits a Application for Payment for a month or not.

CPM update submissions must contain the activity data as specified in (a) through (e) of the ICPM. The update must describe the progress of the project to date. The WN must include a description of the work performed during the update periods, current critical path, the amount of float on the critical path, any delays or disruptions experienced by the Contractor during the period of the update, any change in manpower or equipment, any systematic revision, and any potential delays or disruptions.

**Systematic Revisions to the Schedule of Record.** Systematic Revisions are defined as one or more of the following:

- (a) A change in the specified original duration of an activity;
- (b) A change in the logic of the schedule;
- (c) A change in the calendars or to the calendar to which an activity is assigned;
- (d) A change to resources;
- (e) A change to any actual date, previously established;

- (f) The deletion or addition of an activity;
- (g) A change to, addition of, or deletion of a date or time constraint;
- (h) A change to, addition of, or deletion of an activity code;
- (i) A change to an activity description; and
- (j) Any change other than updating an activity.

If the Contractor indicates in the WN that a monthly CPM update contains no systematic revisions from the previous CPM Schedule of Record, the monthly CPM update must consist solely of updating the previous CPM schedule of record with actual data (actual start dates, actual finish dates, completion percentage, etc.). In the event the Contractor is submitting a monthly CPM update without any systematic revisions, no pre-coordination with the Owner and/or A/E is required.

When the Contractor proposes to make a systematic revision(s) to the CPM, the Contractor (including its scheduling representative) must verbally discuss the proposed revision(s) with the Owner and Architect/Engineer. If the revision(s) is/are determined to be minor in nature, the Owner and Architect/Engineer will allow the Contractor to include the revision on the next CPM Update. If the Owner or Architect/Engineer determines that the revision is not minor in nature, the Contractor must submit its proposed systematic revision(s) in writing to the Owner and Architect/Engineer for review and approval prior to deviating from the CPM Schedule of Record.

The proposed revision(s) must describe the reason for the proposed revision(s), the resulting critical path, and all particulars of the revision. These must include, but not be limited to, changes in the method or manner of the work, changes in resources, addition or deletion of manpower, increased or

decreased quantities, defective work, and acceleration of work.

After review, the A/E and Owner shall provide direction on what systematic revisions, if any, are acceptable. The Contractor shall submit its monthly CPM Schedule based on this direction.

**Approval and/or Acceptance of Monthly CPM Schedule Update.** The Owner, with input from the A/E shall approve, accept or reject the Contractor's monthly CPM Schedule update.

Approval: The Owner will approve a CPM Schedule update if (1) the update accurately reflects the project status as of the data date, (2) any systematic revisions are acceptable, (3) the schedule meets all other contractual requirements, and (4) the schedule's projected Substantial Completion date is at or precedes the contractual Substantial Completion date.

An approved CPM Schedule Update becomes the CPM Schedule of Record and no further action is required by the Contractor.

Acceptance: The Owner will accept but not approve a CPM Schedule update if (1) the update accurately reflects the project status as of the data date, (2) any systematic revisions are acceptable, and (3) the schedule meets all other contractual requirements but the schedule's projected Substantial Completion date is later than the contractual Substantial Completion date.

An accepted CPM Schedule Update becomes the CPM Schedule of Record but the Contractor must take corrective action to return the project to schedule so that Substantial Completion can be achieved within the Contract Time. Before the next CPM Schedule Update, the Contractor shall submit a written description to the Owner and the A/E of its plan to overcome the delay.

Upon approval or acceptance by the Owner and Architect/Engineer, the update will become the CPM schedule of record for the period between its data

date and the data date of the next approved update.

**Rejection:** The Owner may reject a CPM Schedule update if (1) the update does not accurately reflect the project status as of the data date, (2) utilized systematic revisions are not acceptable, (3) the schedule does not meet any contractual requirement, or (4) the schedule's projected Substantial Completion date is later than the contractual Substantial Completion date for two (2) or more consecutive months and the Contractor is not making adequate efforts to remedy the Delay.

A rejected CPM Schedule Update must be reworked to incorporate the comments of the Owner and/or the A/E and be resubmitted to the Owner and the A/E. Resubmittal by the Contractor must be made within seven calendar days after receipt of the Owner and/or Architect/Engineer's review comments. The Owner reserves the right to reject any proposed revision which adversely impacts the Owner, utilities, or other concerned parties. **No new schedule update shall be submitted until a rejected Update is resubmitted and accepted or approved by the Owner.**

Failure to timely submit a CPM Schedule update may result in the Architect/Engineer or Owner withholding payment until submission and approval/acceptance. Failure to timely resubmit a CPM Schedule update which can be approved or accepted by the Owner may result in the Architect/Engineer or Owner withholding payment until an acceptable Update or Revision is submitted.

Updates must not include any systematic revisions to the previous CPM Schedule of Record, unless prior approval by the Owner and Architect/Engineer is received for the insertion of revisions.

The Contractor will attend bi-weekly progress meetings at the project site. At these meetings, the Contractor will provide a report on the actual status of the Work as compared to the latest

CPM Schedule of Record.

### **11.2.3 Coordination with Other Schedules.**

The Contractor must revise its Progress Schedule as necessary to conform to the overall Project Progress Schedule incorporating schedules of the Owner and any Separate Contractors as provided in Subsection 7.1.4.

### **11.2.4 Review and Approval of Schedules.**

The Contractor's Progress Schedule must include, at no additional cost, details requested by the Owner or the Architect/Engineer and be in the format specified in the Contract Documents and as provided in this Article 11. The Owner and the Architect/Engineer will review and approve or take other appropriate action on the Contractor's Progress Schedule, but only for the limited purpose of checking for general conformance with the requirements of the Contract Documents, this Article 11, and the schedules of the Owner, Separate Contractors and other forces permitted by the Owner to perform work at the Site. Any changes to the schedule required by the Owner or the Architect/Engineer must be made by the Contractor and the schedule resubmitted to the Owner for approval. Review and approval or acceptance of the schedule does not relieve the Contractor of its obligations to complete the Work within the Contract Time or any interim completion dates required by the Contract Documents, nor does it constitute approval of any construction means, methods, techniques, sequences or procedures. The approval or acceptance of any schedule or any schedule adjustment made as part of the approval/acceptance of any schedule does not constitute, nor does it provide the basis for, any Claim for an increase of the Contract Time or any Claim for an increase in the Contract Sum.

### **11.2.5 Schedule of Submittals.**

The Contractor must prepare and keep current, for the Owner's and the Architect/Engineer's approval, a Schedule of Submittals which is part of the Progress Schedule. The Schedule of Submittals must allow at least thirty (30) days for review and approval of each Submittal by the Architect/Engineer, and sufficient additional time, if required, for (i) review and approval by regulatory bodies and (ii) their correction and resubmission by the Contractor and any Subcontractors or Suppliers. The Schedule of Submittals must identify all schedules, Shop Drawings, Product Data, Samples, Warranties, operating manuals and other Submittals provided for review or required for approval by

the Owner or the Architect/Engineer, which indicates the dates or times which the Contractor proposes to submit each such Submittal (allowing sufficient time for review, correction and resubmission if required, and approval) and the dates or times on or within which such Submittals must be approved in order to avoid a delay in the progress of the Work.

### **11.3 PROJECT PROGRESS**

**11.3.1 Contract Time Reasonable.** By executing the Contract, the Contractor confirms that the Contract Time is a reasonable period for performing the Work.

**11.3.2 Time is of Essence.** The Contractor acknowledges that completion of the Contract by the dates specified for Substantial and Final Completion is critical to the Owner, time being of the essence.

**11.3.3 Contractor to Proceed Expeditiously.** The Contractor must proceed expeditiously with adequate forces and maintain progress in accordance with the latest approved Progress Schedule.

**11.3.4 Conformance to Schedules.** The Contractor must conform to the most recently approved Progress Schedule. The Contractor must complete the indicated Work or achieve the required percentage of completion, as applicable, within any interim completion dates established in the most recently approved Progress Schedule.

**11.3.5 Progress Record.** The Contractor must maintain at the Site, available to the Owner and the Architect/Engineer for their reference during the progress of the Work, a color copy of the latest approved Progress Schedule, a copy of the latest CPM Schedule of Record (if different from the latest approved Progress Schedule) and any approved revisions thereto. **The Contractor must keep current records of and mark on a copy of the CPM Schedule of Record the actual commencement date, progress, and completion date of each scheduled activity indicated on the Progress Schedule.**

**11.3.6 Substantial Completion Within Contract Time.** The Contractor must achieve Substantial Completion within the Contract Time.

**11.3.7 No Damages for Prevention of Early Completion** The Contractor represents that its bid includes all costs, overhead and profit which

may be incurred throughout the Contract Time and the period between Substantial and Final Completion. Accordingly, **the Contractor may not make any Claim for delay damages based in whole or in part on the premise that the Contractor would have completed the Work prior to the expiration of the Contract Time but for any claimed delay.**

**11.3.8 Acceleration to Comply with Schedule.** If the Contractor's progress is not maintained in accordance with the latest approved Progress Schedule, or the Owner determines that the Contractor is not diligently proceeding with the Work or has evidence reasonably indicating that the Contractor will not be able to conform to the most recently approved Progress Schedule, the Contractor must, promptly and at no additional cost to the Owner, take all measures necessary to accelerate its progress to overcome the delay and ensure that there will be no further delay in the progress of the Work and notify the Owner thereof. Any extension of working hours requires approval of the Owner, which will not be unreasonably withheld but may be subject to reasonable conditions including payment for additional or overtime services of the Owner, the Architect/Engineer and any other applicable consultants, testing or regulatory agency costs.

**11.3.9 Acceleration of Schedule.** The Owner reserves the right to issue a written directive to accelerate the Work which may be subject to an appropriate adjustment, if any, in the Contract Sum. **If the Owner directs an acceleration of the Project Schedule and no adjustment is made in the Contract Sum, or if the Contractor disagrees with any adjustment made, the Contractor must file a request for increase to Contract Time as provided in Article 12 or any Claim for such will be deemed to be conclusively waived.**

### **11.4 SUSPENSION OR STOPPAGE OF WORK**

**11.4.1 Owner's Right to Stop the Work.** If the Contractor fails to correct Work, or any portion thereof, which is not in accordance with the requirements of the Contract Documents or fails on more than one occasion to carry out Work in accordance with the Contract Documents, the Owner may, order the Contractor to stop the Work, or any portion thereof, until the cause for such order has been eliminated. The Owner or its designee, acting in the capacity of a building inspection official, has the power to stop Work as may be necessary to



enforce compliance with applicable codes and regulations. Work stoppage in accordance with this Subsection does not entitle the Contractor to an increase in Contract Time or damages for delay. If the Contractor disagrees with the Owner's right to stop the Work, the Contractor must file a Claim for increase in the Contract Time and/or increase in the Contract Sum in accordance with Articles 11 and/or 12 as applicable or any Claim for such will be deemed to be conclusively waived.

**11.4.2 Owner's Right to Suspend Work for Convenience.** The Owner may, without cause and for its convenience, order the Contractor in writing to suspend, delay or interrupt the Work in whole or in part for such period of time as the Owner may determine, subject to an appropriate adjustment in the Contract Time and/or Contract Sum. **The Contractor is not entitled to profit on any adjustment to the Contract Sum due to any such stoppage, suspension, interruption or delay.** If no adjustment is made in the Contract Sum as a consequence of the suspension order, or if the Contractor disagrees with any adjustment made, the Contractor must file a Claim for increase in the Contract Time and/or increase in the Contract Sum in accordance with Articles 11 and/or 12 as applicable or any Claim for such will be deemed to be conclusively waived.

**11.4.3 Disagreements Involving Non-payment.** In the event of any disagreement between the Contractor and the Owner involving the Contractor's Claim to entitlement of any payment, the Contractor must diligently proceed with the Work pending resolution of the disagreement subject to the provisions of Section 7(G) of the Contract.

## 11.5 DELAYS

**11.5.1 Excusable Delay.** An excusable Delay is a Delay in the progress of the Work which at the time of the Delay was a critical path activity as shown on the most recent CPM Schedule of Record and which prevents the Contractor from achieving Substantial Completion before the expiration of the Contract Time, caused by conditions which could not reasonably be anticipated by, are beyond the control of, and are without the fault or negligence of the Owner, as set forth in 11.5.2, the Contractor or anyone for whose acts the Contractor is responsible. **Excusable Delay does not include any delay caused in whole or in part by any Subcontractor, Sub-subcontractor or Supplier which is considered unexcused**

**Delay. There shall be no compensation whatsoever for excusable delay.** Excusable Delay may, but does not necessarily, include:

- .1 Weather delay as further defined in Subsection 11.6.3;
- .2 Act or omission of government and regulatory agencies and officials (other than the Owner in its capacity as Owner);
- .3 Act or omission by third parties including utilities;
- .4 Catastrophic event such as fire, flood and unavoidable casualties; and
- .5 Strike or labor dispute.

**11.5.2 Compensable Delay.** Compensable Delay is limited to delay in the progress of the Work which at the time of the delay was critical path activity as shown on the most recent CPM Schedule of Record and which prevents the Contractor from achieving Substantial Completion before the expiration of the Contract Time, caused solely and exclusively by acts or omissions of the Owner (excepting actions taken by the Owner to protect the public health or safety or to conform to law).

**11.5.3 Unexcused Delay.** Unexcused Delay is delay in Work which at the time of the delay was critical path activity as shown on the most recent CPM Schedule of Record and which prevents the Contractor from achieving Substantial Completion before the expiration of the Contract Time, and which is not excusable delay or compensable delay. No increase in the Contract Time or increase in the Contract Sum will be provided for an unexcused Delay.

## 11.6 TIME AND RELATED COST ADJUSTMENTS

**11.6.1 Notice of Delay.** The Contractor must provide written notice of any actual or prospective Delay promptly, and in no event later than five (5) days after the occurrence of the event or omission giving rise to such Delay. The notice must be provided both to the Architect/Engineer and the Contract Administrator within the specified time.

The written notice must contain the following information:

- .1 A detailed statement of the reasons and causes for the Delay;
- .2 Inclusive dates of the Delay (start date only if end date is not known);



- .3 Specific portions of the Work affected by the actual or prospective Delay; provide specific Activity Names and Numbers from the most recent CPM schedule of record
- .4 Status of Work (affected Activities) affected before commencement of the Delay;
- .5 Effect of the Delay on available "float" for referenced Activities; and
- .6 Specific action (if any) required by the A/E and/or the Owner to remedy or mitigate the Delay.

If the Contractor fails to provide the written notice containing the specified information, within the five (5) days, as prescribed above, the Contractor will not receive any consideration, in a Claim for an increase in Contract Time and/or for a Claim for an increase in the Contract Sum, for the time period before a written notice (containing the specified information) is provided to the Owner and the A/E.

**11.6.2 Continuing Delay.** In the case of a continuing Delay (an actual or prospective Delay to a activity or activities for which the Contractor cannot progress pending further information), the Contractor must provide the initial notice (as described in the preceding subsection) and a further notice at each progress meeting throughout the duration of the Delay. The further notices must contain all of the specific information required in the preceding Subsection. **A continuing Delay ends when the Contractor has sufficient information to progress the affected work, not when the affected work is completed. The Contractor must request an increase in the Contract Time in accordance with 11.6.3 when the delayed work can progress again.**

**11.6.3 Request for an Increase in Contract Time.** If the Contract contends that the Delay is an excusable or compensable Delay, and it is entitled to an increase in Contract Time, the Contractor, in addition to providing the notice in Subsection 11.6.1, must submit a request for additional Contract Time to the Owner and the A/E within fifteen (15) days of the event ending the Delay. **The Contractor's failure to provide the written request for an increase in Contract Time containing the information specified in the following Subsection within the fifteen (15) days prescribed above will be**

**conclusively deemed a waiver of any Claim for Delay arising from such occurrence.**

**11.6.4 Concurrent Delay.** Concurrent delay is two or more separate Delays, as defined in Section 11.5, in the progress of the Work, one or more which is caused by the Owner and one or more which is caused by the Contractor which, at the time of the Delay, delayed critical path activities as shown on the most recent CPM Schedule of Record, that occur during the same time period, and each Delay independently delayed the Contractor from achieving Substantial Completion before the expiration of the Contract Time. Any concurrent Delay will be considered an excusable Delay; therefore, the Contractor will receive a corresponding increase in Contract Time, but will not receive any compensation for a concurrent Delay.

**11.6.5 Supporting Documentation.** The Contractor's request for an increase in the Contract Time must identify those portions of the latest CPM Schedule of Record affected by the delay and must include an estimate of the cost and probable effect of the delay, if any, on the progress of the Work. Supporting documentation must include, but is not limited to:

- .1 A written detailed statement of the reasons and causes for the delay;
- .2 Inclusive dates of the delay;
- .3 Specific portions of the Work affected by the actual or prospective delay; provide specific Activity Names and Numbers from the most recent CPM schedule of record;
- .4 Status of Work affected before commencement of the delay;
- .5 Effect of the delay on available "float" time for the referenced activities and the Project;
- .6 A critical path method (CPM) analysis demonstrating that the delay has affected an activity (or activities) on the critical path of the most recent CPM schedule of record at the time of the occurrence of the delay; and
- .7 If the Contractor claims that the delay is an excusable delay or compensable delay, evidence that the delay was unforeseeable, beyond the Contractor's control, and without the fault or negligence of the Contractor or the negligence of anyone for whose

acts the Contractor is responsible including any Subcontractor, sub-subcontractor or Supplier; and in the case of a compensable delay, was caused solely and exclusively by the acts or omissions of the Owner (excepting actions taken by the Owner to protect the public health or safety or to conform to law) or anyone for whose acts the Owner is responsible, and which are unreasonable under the circumstances involved and not reasonably within the contemplation of the parties.

**11.6.6 Additional Time for Unusually Severe Weather.** In order for the Contractor to be entitled to an increase of the Contract Time under this Subsection, the following conditions must be satisfied:

- .1 The weather experienced at the Project Site during the Contract period must be found to be unusually severe, that is, more severe than the adverse weather anticipated for the Project location during any given month;
- .2 The unusually severe weather must delay Work which at the time of the unusually severe weather was a critical path activity as shown on the most recent CPM Schedule of Record and which prevents the Contractor from achieving Substantial Completion before expiration of the Contract Time. The delay must be beyond the control and without the fault or negligence of the Contractor. For example, the impacted critical activity must not have occurred during unusually severe weather due to previous unexcused delays; and
- .3 The Contractor must have provided a request for an increase in the Contract Time of the weather-related delay complying with Subsection 11.6.3 above. The last day of the each month will be the date of the end of the delay for purposes of the fifteen (15) day requirement for submission. Any request for an increase in the Contract Time for a weather-related delay must be submitted by the 15<sup>th</sup> of the following month.

The following schedule of monthly anticipated adverse weather delays will constitute the base line for monthly weather time evaluations. The

Contractor's Progress Schedule including all updates must reflect these anticipated adverse weather delays in all weather dependent activities.

**MONTHLY ANTICIPATED ADVERSE WEATHER DELAY**

|           |             |
|-----------|-------------|
| January   | 7 work days |
| February  | 6 work days |
| March     | 6 work days |
| April     | 7 work days |
| May       | 7 work days |
| June      | 6 work days |
| July      | 4 work days |
| August    | 5 work days |
| September | 3 work days |
| October   | 5 work days |
| November  | 4 work days |
| December  | 4 work days |

Upon Notice to Proceed and continuing throughout the Contract, the Contractor must record on its daily CQC and/or field reports, the occurrence of adverse weather and resultant impact to actual and scheduled Work. Actual adverse weather delay days must prevent Work on critical path activities for fifty (50) percent or more of the Contractor's scheduled workday. The number of actual adverse weather delays must include only the Contractor's scheduled workdays impacted by actual adverse weather (even if the adverse weather occurred in the previous month), be calculated chronologically from the first to the last day each month, and be recorded as full days. If the Contractor has complied with Subsection 11.6.3 and the number of actual adverse weather delay workdays exceeds the number of days anticipated in the table above, and have adversely affected critical path weather-dependent activities, the Contractor is entitled to an increase in the Contract Time, but not an increase in the Contract Sum (i.e. weather delays are excusable delays).

The preceding calculation and methodology is based on work days. To convert any justified time increase to calendar days, the number of justified work days shall be multiplied by (7/5 = 1.4), and rounded to the nearest whole number, to determine justified calendar days [Example: 2 work days would be converted to 2.8 (3) calendar days.]

**11.6.7 Strikes and Labor Disputes.** If strikes or labor disputes are to be considered as the

basis for an excusable delay, they must be documented by data evidencing (i) the trades directly and indirectly involved in or affected by the strike or labor dispute, (ii) reasons for the strike or labor dispute, (iii) the onset and duration of the strike or labor dispute, and (iv) the measures taken by the Contractor to avoid or overcome the effects of any delay.

**11.6.8 Review and Adjustment of Schedules.** Upon receipt of a request for an increase in the Contract Time from the Contractor complying with Subsection 11.6.3 and 11.6.4 (and if applicable 11.6.5) above, the Owner will review the most recent CPM Schedule of Record to determine (i) whether the delay is in fact an excusable or compensable delay, and (ii) whether any adverse effects of the delay can be overcome by an adjustment in the Progress Schedule including the application of any unused "float" time available in the schedule. The Owner may require the Contractor to submit a more detailed Progress Schedule than previously required in order to permit the Owner to evaluate the delay. Based on such review, the Contractor must, if required by the Owner, submit for the Owner's approval a revised Progress Schedule, which minimizes the adverse effects of the delay. After review, the Owner will issue a determination of the validity of the Contractor's request. If justified, the Owner will prepare a Change Order or Contract Amendment for an increase in the Contract Time.

**11.6.9 Limitation on Adjustments.** No increase in the Contract Time or increase in the Contract Sum will be allowed for any delay or part thereof occurring more than fifteen (15) days before written request for an increase in the Contract Time for the delay is provided by the Contractor.

1. No increase in the Contract Time or increase in the Contract Sum will be made to the extent that performance is, was or would have been suspended, delayed or interrupted by another cause for which the Contractor is responsible. No increase in the Contract Sum will be made to the extent performance was or would have been suspended, delayed or interrupted by another cause for which the Owner is not solely and exclusively responsible.
2. **The Contractor will not receive any compensation for profit, additional bond cost or overhead (which**

**includes extended office overhead and site-specific overhead and general conditions) or any other cost or compensation or any other damages of any kind or nature whatsoever whether incurred by the Contractor, its Subcontractor or Suppliers for delay, all of which are irrevocably waived by Contractor where the delay results from performance of additional Work (Change Order or Field Order Work including bilateral, unilateral, and constructive changes) beyond the Work required by the Contract Documents and the Contractor is paid for the additional Work. The Contractor acknowledges and agrees that the profit, additional bond cost and overhead (which includes extended office overhead and site-specific overhead and general conditions) if any, incurred by the Contractor in performing work beyond the Work required by the Contract Documents and any and all other costs, compensation or damages due Contractor (including any of its Subcontractors or Suppliers), is included in, and payable to the Contractor as part of the Change Order or Field Order Work. Contractor waives any and all other damages and cost of any nature or kind whatsoever including Claims for local and cumulative impacts as a result of such Change Order Work and any and all other Claims of any type or nature whatsoever including any Claim for loss of productivity or loss of efficiency.**

3. The Contractor will be compensated for compensable delays only for actual and direct damages resulting from such compensable delays. Actual direct damages are limited to site specific general conditions and do not include any indirect costs such as home office overhead. The Contractor will be compensated for such actual and direct damages for compensable delays not attributable to performance of Change Order. Work for which the Contractor is not otherwise compensated in an amount not to exceed the lesser of (i) a daily rate computed by dividing eight

percent (8%) of the original Contract Sum by the original Contract Time or (ii) a daily rate computed by dividing the Contractor's profit, bond cost and site-specific overhead (but not home office overhead) for the original Contract Sum by the original Contract Time.

4. **The Contractor for itself and its Subcontractors and Suppliers, irrevocably waives any and all other compensation and delay damages as a result of any compensable delays, including without limitations any Claims for any indirect cost and any Claims for loss of productivity or loss of efficiency.**

**11.6.10 Denial of Adjustments in Time or Money.** In the event the Owner denies the Contractor's Claim for a change in the Contract Time or, in the case of a compensable delay, a change in the Contract Sum, the Contractor may, within thirty (30) days after such denial, submit a Claim as provided in Article 16. Submissions made prior to the denial must be resubmitted as part of the Claim after the denial. Any Claim on account of denial of a change which is not made within such thirty (30) days of the denial will be deemed conclusively to have been waived.

## **11.7 DAMAGES FOR DELAY**

### **11.7.1 Delay Damages.**

- .1 **By executing a Bilateral Change Order, Field Order or Contract Amendment, the Contractor represents that the Contractor is not entitled to an increase in Contract Time or an increase in the Contract Sum beyond that specified in the Bilateral Change Order, Field Order or Contract Amendment for the Work performed or to be performed under the Modification. Nor is the Contractor entitled to an increase of the Contract Time or an increase in the Contract Sum as a result of the issuance by the Owner of a Unilateral Change Order or Field Order unless a Claim for an increase in the Contract Time and/or a Claim for an increase in the Contract Sum is made by the Contractor as and when required by this Article 11 and Article 12.**

- .2 **No Claim for an increase in the Contract Time and/or Claim for an increase in the Contract Sum or Claims for damages may be made by the Contractor or paid to the Contractor for any delay, disruption, inefficiency, interference or hindrance from any cause whatsoever, whether foreseeable or not, including (i) acts or omissions by the Owner, its agents, employees or consultants, (ii) Contract Documents that are negligently prepared or contain inaccurate statements, or (iii) force majeure and circumstances beyond the Contractor's control. The sole remedy for delays, disruptions or hindrances will be non-compensable increases in Contract Time for completion of the Work.**

- .3 **The provisions of the preceding subsection do not apply to Claims that meet all of the following conditions: (i) the Claim arises under the Contract; (ii) the Claim is limited to actual and direct damages (i.e. profit, additional bond costs (if any) and overhead (only site-specific overhead and not including home office overhead)) incurred as a result of a delay in completing the Project which the Contractor acknowledges are fully compensated for by payment of the adjustment amount specified in Subsection 11.6.9; (iii) the Contract establishes a time limit for achieving Substantial Completion and the Claim is for critical path delays that prevent achievement of Substantial Completion of the Contract within that time limit; (iv) the delay for which damages are claimed is caused solely and exclusively by the Owner; (v) the delay is not caused by actions taken by the Owner to protect the public health or safety or to conform to law; and (vi) the Contractor has fully complied with Section 11.6.**

- .4 **An increase in Contract Time shall be granted only for an excusable delay that is beyond the**

**Contractor's control and occurs without the Contractor's fault or negligence. No increase in Contract Time will be granted in the absence of a written request for the increase in Contract Time complying with Section 11.6.**

**11.7.2 Liquidated Damages.** The Owner will suffer financial loss if Substantial Completion of the Work is not achieved within the Contract Time. Accordingly, and in lieu of actual damages or proof thereof, the Contractor agrees to pay, as Liquidated Damages and not as a penalty, the amount stipulated in the Contract for each and every day of unexcused delay in achieving Substantial Completion.

**11.7.3 Assessment of Liquidated Damages.** The Owner may assess and deduct the applicable amount of Liquidated Damages from any payment due the Contractor. If the unpaid balance of the Contract Sum is less than the amount of the Liquidated Damages, the Contractor or its Surety must pay the deficiency to the Owner upon demand.

## **ARTICLE 12**

### **CHANGES**

#### **12.1 CHANGE INSTRUMENTS**

**12.1.1 Amendment only by Written Modification.** The Contract may be amended or modified only by a written Modification as defined in Subsection 1.1.39.

**12.1.2 Change Instruments.** Changes in the scope of the Contract may be effected only by a written Amendment signed by the Contractor and Owner. Changes in the Work which are within the general scope of the Contract may be effected, without invalidating the Contract, by a Change Order or Field Order. The Contract Time and Contract Sum may be changed only by a Change Order or Contract Amendment.

**12.1.3 Change Proposals.** The Contractor must submit a request for change to the Contract Sum (change proposal) covering a contemplated change within ten (10) days after request of the Owner or the Architect/Engineer or within ten (10) days of the event giving rise to the Contractor's request for a change in the Contract Sum or Contract Time. No increase in the Contract Time or increase in the Contract Sum or will be allowed the Contractor for the cost or time involved in making change proposals. Change proposals must define or confirm in detail the Work which is proposed to

be added, deleted, or changed and must include any adjustment which the Contractor believes to be necessary in (i) the Contract Time, or (ii) the Contract Sum. Any proposed adjustment must include detailed documentation including but not limited to: cost, properly itemized and supported by sufficient substantiating data to permit evaluation including cost of labor, materials, supplies and equipment, rental cost of machinery and equipment, additional bond cost, plus a fixed fee for profit and overhead (which includes office overhead and site-specific overhead and general conditions) of ten percent (10%) if the Work is performed by the Contractor, or five percent (5%) if the Work is performed by a Subcontractor or Sub-subcontractor. The Subcontractors or Sub-subcontractors overhead and profit in turn must not exceed ten percent (10%). Change proposals are binding upon the Contractor and may be accepted or rejected by the Owner in its discretion. Acceptance of a change proposal may only be made in a written Modification. The Owner may, at its option, instruct the Contractor to proceed with the Work involved in a unilateral Change Order or unilateral Field Order in accordance with this Article 12, without accepting the change proposal in its entirety.

#### **12.1.4 Preparation and Submission of Change Orders and Contract Amendments.**

If the Owner determines that a change proposal is appropriate, the Contract Administrator or designee will prepare and submit a request for a Change Order or Contract Amendment providing for an appropriate adjustment in the Contract Time or Contract Sum, or both, for further action by the Director. No such change is effective until the Change Order has been approved by the Director.

**12.1.5 Performance of Changes.** Unless otherwise provided, the Contractor must perform changes in the Work promptly upon receipt of executed Modifications under applicable provisions of the Contract Documents.

## **122 CHANGE ORDERS**

**12.2.1 Utilization.** A Change Order is a written directive by the Owner to the Contractor directing a change in the Work which is within the general scope of the contract and which may increase or decrease the Contract Time and/or the Contract Sum issued with or without the consent of the Contractor.

**12.2.2 Adjustments in Amount Payable to Contractor.** A Change Order may provide for an adjustment in the amount payable to the



Contractor based only on one of the following methods:

- .1 A fixed or not-to-exceed sum agreed to by the Owner and Contractor and stated in the change instrument;
- .2 Unit Prices stated in the Contract Documents; or
- .3 Reasonable and fair cost estimate, properly itemized and supported by sufficient substantiating data to permit evaluation which will be limited to estimated costs of labor, materials, supplies and equipment, rental cost of machinery and equipment, additional bond cost, plus a fixed fee for profit and overhead (which includes office overhead and site-specific overhead and general conditions) of ten percent (10%) if the Work is performed by the Contractor, or five percent (5%) if the Work is performed by a Subcontractor or Sub-subcontractor. The Subcontractors or Sub-subcontractors overhead and profit in turn must not exceed ten percent (10%). **The total percentage of overhead and profit payable by the Owner (to both the Contractor and all subtier subcontractors), regardless of the subtier which performs the work, shall not exceed twenty percent (20%).**
- .4 Actual cost, properly itemized and supported by sufficient substantiating data to permit evaluation which will be limited to actual cost of labor, actual cost of materials, supplies and equipment, actual rental cost of machinery and equipment, additional bond cost, plus a fixed fee for profit and overhead (which includes office overhead and site-specific overhead and general conditions) of ten percent (10%) if the Work is performed by the Contractor, or five percent (5%) if the Work is performed by a Subcontractor or Sub-subcontractor. The Subcontractors or Sub-subcontractors overhead and profit in turn must not exceed ten percent (10%). **The total percentage of overhead and profit payable by the Owner (to both the Contractor and all subtier subcontractors), regardless of the subtier which performs the work,**

**shall not exceed twenty percent (20%).**

- .5 In the absence of an agreement between the Owner and Contractor, the amount must be determined in accord with Subsection 12.2.2.2 or 12.2.2.3 above, using whichever will result in the lowest cost to the Owner.

#### **12.2.3 Adjustments in Progress Schedule.**

A Change Order may provide for an adjustment in the Contract Time if justified by the requirements of Article 11.

#### **12.2.4 Absence of Proposed Adjustments.**

**If a Change Order is silent as to any adjustment to the Contract Time or the Contract Sum, it will be conclusively presumed that none is intended and none will be allowed unless the Contractor files an objection as and when specified in the following Subsection**

**12.2.5 Action Upon Receipt.** Upon receipt of a Unilateral Change Order, the Contractor must promptly proceed with the change in the Work involved. The Contractor must advise the Owner and the Architect/Engineer in writing, promptly and in no event later than ten (10) days after issuance of the Change Order, of the Contractor's objection (i) to the amount or method, if any, provided for in the Unilateral Change Order for adjustment in the Contract Time or in the amount payable to the Contractor, or (ii) to the absence of any adjustment to the Contract Time or the Contract Sum. Any objection to be valid must contain the specific adjustment in the Contract Time or the Contract Sum to which the Contractor claims it is entitled including a detailed explanation of the basis for its request. A Claim for an increase in the Contract Time, to be valid, must contain the supporting documentation specified in Subsection 11.6. A Claim for an increase in the Contract Sum, to be valid, must further be documented and calculated as specified in Subsection 12.2.2. **Failure of the Contractor to object as and when specified in this Subsection is deemed an acceptance of the Unilateral Change Order as issued and a waiver of any Claim by the Contractor to any adjustment to the Contract Time or the Contract Sum.**

### **12.3 FIELD ORDERS**

**12.3.1 Utilization.** A Field Order is a written instruction issued by the Owner to the Contractor directing a change in the Work when



unforeseen and unanticipated conditions arise which require immediate action to mitigate costs or avoid delays. It may provide for additional compensation to be paid to the Contractor (outside of the Contract), but does not change the Contract Time or Contract Sum.

- .1 The Owner may issue a unilateral Field Order to avoid Project Delay before the Contractor has prepared its cost proposal. In these instances, the Contractor should, unless noted otherwise on the Field Order, submit its cost proposal within ten (10) days and the Owner will review the cost proposal in accordance with Section 12.3.
- .2 The Owner may issue a Field Order directing the Contractor to proceed with work which the Contractor and the Owner and/or A/E disagree as to whether it is a Change to the Work. In these instances, the Contractor shall submit its Claims for an increase in the Contract Time and/or an increase in the Contract Sum in accordance with Articles 11 and 12 and the County will make a determination on the Claims. If the Contractor disagrees with the determination, the Contractor must file a Dispute in accordance with Article 16.

**12.3.2 Adjustments in Amount Payable to Contractor.** A Field Order may provide for an adjustment in the amount payable to the Contractor based only on one of the following methods:

- .1 A fixed or not-to-exceed sum stated in the change instrument;
- .2 Unit Prices stated in the Contract Documents;
- .3 Reasonable and fair cost estimate, properly itemized and supported by sufficient substantiating data to permit evaluation which will be limited to estimated costs of labor, materials, supplies and equipment, rental cost of machinery and equipment, additional bond cost, plus a fixed fee for profit and overhead (which includes office overhead and site-specific overhead and general conditions) of ten percent (10%) if the Work is performed by the Contractor, or five percent (5%) if the Work is performed by a Subcontractor

or Sub-subcontractor. The Subcontractors or Sub-subcontractors overhead and profit in turn must not exceed ten percent (10%). **The total percentage of overhead and profit payable by the Owner (to both the Contractor and all subtier subcontractors), regardless of the subtier which performs the work, shall not exceed twenty percent (20%);**

- .4 Actual cost, properly itemized and supported by sufficient substantiating data to permit evaluation which will be limited to actual cost of labor, actual cost of materials, supplies and equipment, actual rental cost of machinery and equipment, additional bond cost, plus a fixed fee for profit and overhead (which includes office overhead and site-specific overhead and general conditions) of ten percent (10%) if the Work is performed by the Contractor, or five percent (5%) if the Work is performed by a Subcontractor or Sub subcontractor. **The term 'cost' as used in this subsection is limited to the cost incurred in the actual performance of the work.** The Subcontractors or Sub-subcontractors overhead and profit in turn must not exceed ten percent (10%). **The total percentage of overhead and profit payable by the Owner (to both the Contractor and all subtier subcontractors), regardless of the subtier which performs the work, shall not exceed twenty percent (20%); or**
- .5 In the absence of an agreement between the Owner and Contractor, the amount must be determined in accord with Subsections 12.3.2.2 or 12.3.2.3 above, using whichever will result in the lowest cost to the Owner.

**12.3.3 Adjustments in Progress Schedule.** A Field Order may not be used to adjust the Contract Time. If the Contractor files an objection under Subsection 12.3.5 below which results in an entitlement by the Contractor to an increase in the Contract Time, it will be implemented by execution of a Change Order or Contract Amendment.

**12.3.4 Absence of Proposed Adjustments.** If a Field Order is silent as to any adjustment

**to the Contract Time or the Contract Sum, it will be conclusively presumed that none is intended and none will be allowed unless the Contractor files an objection as and when specified in the following Subsection.**

**12.3.5 Action Upon Receipt.** Upon receipt of a (unilateral or bilateral) Field Order, the Contractor must promptly proceed with the change in the Work involved. The Contractor must advise the Owner and the Architect/Engineer in writing, promptly and in no event later than ten (10) days after issuance of the Field Order, of the Contractor's objection (i) to the amount or method, if any, provided for in the Field Order for adjustment in the Contract Time or to the Contract Sum, or (ii) to the absence of any adjustment in the Contract Time or to the Contract Sum. **Any objection to be valid must contain the specific adjustment to the Contract Time or the Contract Sum to which the Contractor claims it is entitled including a detailed explanation of the basis for the Claim.** A Claim for an increase in the Contract Time, to be valid, must contain the supporting documentation specified in Section 11.6. A Claim for an increase to the Contract Sum, to be valid, must further be documented and calculated as specified in Subsection 12.2.2. **Failure of the Contractor to object as and when specified in this Section is deemed an acceptance of the Field Order as issued and a waiver of any Claim by the Contractor to an adjustment to the Contract Time or the Contract Sum.**

#### **12.4 DIFFERING CONDITIONS (SITE AND STRUCTURAL)**

**12.4.1 Differing Site Conditions.** This Contract contains a Differing Site Condition clause and requests may be made by the Contractor and, if justified, approved by the Owner for an increase in Contract Time and an increase in the Contract Sum as consequence of differing site or subsurface conditions encountered by the Contractor. For Contract Modification purposes, the Geotechnical Studies establish a baseline for expected subsurface conditions. The Contractor must show a material difference between the Geotechnical Studies and actual subsurface conditions to justify a Contract Modification.

The Contractor must promptly, before conditions are disturbed and in no event later than five (5) days after first observing such conditions, give written notice to the Owner and Architect/Engineer of:

.1 Subsurface or latent physical conditions at the site which differ materially from those indicated in the Contract; or

.2 Unknown physical conditions at the site, of an unusual nature, which differ materially from those ordinarily encountered and generally recognized as inhering in work of the character provided for in the Contract.

**Failure of the Contractor either (i) to provide notice before disturbing the existing conditions or (ii) failure to give notice within five (5) days of first observing such conditions is conclusively deemed a waiver of any Claim relating to such conditions.**

**12.4.2 Differing Structural Conditions in Remodeling or Renovation Contracts.** If this is a Contract for a remodeling or renovation of an existing structure and the Contractor encounters conditions in the structure (not as to the site or subsurface conditions) which differ materially from those indicated in the Contract Documents, the Contractor must give written notice thereof to the Owner and the Architect/Engineer promptly before conditions are disturbed and in no event later than five (5) days after first observing such conditions. **Failure of the Contractor either (i) to provide notice before disturbing the existing conditions or (ii) failure to give notice within five (5) days of first observing such conditions is conclusively deemed a waiver of any entitlement to an increase in the Contract Time and/or an increase in the Contract Sum relating to such conditions.**

**12.4.3 Investigation and Determination by Architect/Engineer.** After receipt of the written notice, the Architect/Engineer will promptly investigate any alleged differing condition(s) and provide a written report of its findings to the Owner. If the Architect/Engineer and Owner determine that the conditions vary materially from the Contract Documents, the Architect/Engineer will produce technical revisions to the Contract Documents as required. The Contractor shall submit Claims for an increase in the Contract Time and/or an increase in the Contract Sum in accordance with Articles 11 and 12 and the Owner will issue a corresponding Modification. To avoid Delay, the Owner may issue a unilateral Field Order or Change Order before receipt of the contractor's Claim. In that instance, a second Modification will be issued after review and acceptance of the

Contractor's Claims. If the Owner determines that the actual conditions are not materially different or that no change in the terms of the Contract is justified, the Owner will so notify the Contractor in writing.

**12.4.4 Claims Over Differing Structural Conditions.** If the Contractor objects to the Owner's finding under Subsection 12.4.3, the Contractor must file a notice as and when provided in Subsection 12.5.1 below and the same will be resolved as provided in Subsection 12.5.2 below. **Failure of the Contractor to file the notice as and when required by Subsection 12.5.1 below and Article 11 of the Contract will be conclusively deemed a waiver of any Claim relating to any such differing condition.**

## **12.5 CONSTRUCTIVE CHANGES AND DISPUTED ADJUSTMENTS**

**12.5.1 Notice to Owner and Architect/Engineer.** The Contractor must advise the Owner (Contract Administrator) and the Architect/Engineer in writing promptly and in no event later than ten (10) days after (i) issuance of any interpretation, clarification, instruction, direction or order whether orally or in writing from either the Owner or the Architect/Engineer, or (ii) the occurrence of any event or discovery of any condition (including any condition as provided in Section 12.4 above), which the Contractor believes or has reason to believe entitles the Contractor to an increase in the Contract Time or an increase in the Contract Sum; and except in the case of an emergency involving possible loss of life or bodily injury or property damage exceeding \$50,000, the required written notice must be provided by the Contractor prior to proceeding with the Work. Failure of the Contractor to provide such notice constitutes an acceptance of the interpretation, clarification, instruction, direction, order, event or condition without adjustment to the amount payable to the Contractor and/or the Contract Time and a conclusive waiver of any Claim relating to the same. Any objection to be valid must contain the specific adjustment to the Contract Time and/or Contract Sum to which the Contractor claims it is entitled including a detailed explanation of the basis for the request. A Claim for an increase in the Contract Time must further contain the supporting documentation specified in Section 11.6. A Claim for an increase in the Contract Sum must further be documented and calculated as specified in Subsection 12.2.2.

**12.5.2 Disputed Adjustments.** All disputed adjustments under this Contract will be determined in accordance with Article 16 if, as conditions precedent thereto, the Contractor has timely provided all notices and objections required under the terms of the Contract.

## **12.6 SUBSTITUTIONS AND OR-EQUAL ITEMS**

**12.6.1 Allowance of Substitutions and Or-Equal Items.** The Contract Sum and Contract Time are based on the requirements of the Contract Documents and use of the materials and equipment specified therein. Proposals to use Substitutions and Or-Equal Items after Contract execution is neither invited nor favored by the Owner. Or-Equal Items will be considered only where permitted by the Specifications, and Substitutions will be considered only where the specified item is not available or where significant overall cost savings are offered to the Owner. No Substitution or Or-Equal Item will be used without specific written acceptance of the Owner, which may be withheld in the sole discretion of the Owner. The determination by the Owner that an item is not an "or-equal" but a proposed Substitution, and any decision by the Owner regarding the acceptability or use of an Or-Equal or Substitution will be final and without further recourse by the Contractor. In making such determinations the Owner may, but will not be required, to rely upon the recommendations of the Architect/Engineer.

**12.6.2 Or-Equal Items.** The Contractor must submit any requests for the use of an Or-Equal Item, if specifically permitted by the Specifications, to the Owner in writing through the Architect/Engineer. If in the Owner's sole discretion an item of material or equipment proposed by the Contractor is functionally equal to that named and sufficiently similar so that no change in design or related Work will be required, it may be considered for eligibility as an Or-Equal Item, in which case further review of the proposed item will, in the Owner's sole discretion, be accomplished subject to compliance with all of the requirements for acceptance of a proposed Substitution except as expressly waived by the Owner. A decision in the Owner's sole discretion that an item of material or equipment proposed by the Contractor does not qualify as an Or-Equal Item, does not preclude a request by the Contractor that it be considered a proposed Substitution under Subsection 12.6.3. An Or-Equal Item may only be accepted by the Owner in writing.

**12.6.3 Substitutions.** After the Contract has been executed, the Owner and Architect/Engineer will consider a formal request submitted by the Contractor for the substitution of products or materials in place of those specified, when such request is accompanied by:

- .1 Evidence that the specified item is unavailable;
- .2 Complete data on the proposed Substitution substantiating compliance with the Contract Documents, including product identification and description, performance and test data, references and samples where applicable, and an itemized comparison of the proposed item with the products specified or named in the Contract Documents;
- .3 Data indicating the effect of the Substitution on the Progress Schedule and the Contract Time, if any, on the general design and artistic effect where applicable, and its effect on work under separate contracts;
- .4 accurate cost data on the proposed item in comparison with the product specified, whether or not the Substitution of such item will require an adjustment to the Contract Sum; and
- .5 Any additional information required by the Owner or the Architect/Engineer to permit evaluation.

**12.6.4 Representations by Contractor.** Requests for Substitution based on Subsection 12.6.3 above are understood to mean that the Contractor:

- .1 Represents having personally investigated the proposed Substitution and having determined that it is equal or superior in all respects to that specified;
- .2 Will warrant the Substitution to the same extent and will provide the same or better special Warranties and Guarantees for the Substitution as was required for the item originally specified;
- .3 Certifies that the cost data is complete and includes all related costs under the Contract including, if known to the Contractor, cost under separate

contracts and the Architect/Engineer's redesign costs, and that the Contractor waives all Claims for additional costs and agrees to pay all such additional costs, whether known or not, related to the Substitution including any cost which subsequently become apparent;

- .4 Certifies that the schedule and time data are complete and include all related time under the Contract (excluding time under separate contracts and for the Architect/Engineer's redesign), and that the Contractor waives all Claims for delay related to the Substitution which subsequently become apparent; and
- .5 Will coordinate the installation of the proposed Substitute, making such changes as may be required for the Work to be complete in all respects.

**12.6.5 Costs Borne by Contractor.** The Contractor must bear all costs of preparing and submitting requests for Substitutions and the use of Or-Equal Items. The Contractor bears the risk for the proper fit and performance of substituted and "or-equal" materials and the burden for additional work, time and expense resulting from substituted and "or-equal" materials. The costs of the Owner's and Architect/Engineer's additional services attributable to their review, evaluation, acceptance, design and implementation must also be borne by the Contractor.

**12.6.6 Timeliness.** All requests for use of an Or-equal or Substitution must be made in a timely manner in sufficient time to permit adequate review and approval or acceptance by the Owner and the Architect/Engineer, coordination with Separate Contractors, and preparation of any changes to the Contract Documents which would be required by acceptance of any proposed Substitution or Or-Equal Item so as not to delay the Work or the Project.

**12.6.7 Improper Substitutions.** Submission of an item as part of a Shop Drawing, Sample or Product Data does not constitute compliance with Section 12.6, even if the Shop Drawing, Sample or Product Data is or has been approved. **The Owner may direct removal of any unapproved Substitutions and/or Or-Equal items, and replacement with approved**

items, at Contractor's cost and with no increase in the Contract Time.

## **ARTICLE 13**

### **PAYMENTS**

#### **13.1 SCHEDULE OF VALUES**

**13.1.1 Submission.** Within ten (10) days after issuance of a Notice to Proceed, the Contractor must submit to the Architect/Engineer a Schedule of Values which allocates the Contract Sum among all portions of the Work.

**13.1.2 Form and Contents of Schedule of Values.** The Schedule of Values must be prepared in such a manner that each item of Work and each subcontracted item of work is shown as one or more line items on AIA Document G703, Continuation Sheet (latest edition), or such other form as may be prescribed by the Owner. Unless otherwise required, each line item must include its allocable share of the Contractor's overhead and profit. The Schedule of Values must be prepared in such detail and must be supported by such data to substantiate its accuracy as required by both the Owner and the Architect/Engineer.

**13.1.3 Review and Approval.** The Architect/Engineer will review the Schedule of Values with the Owner and advise the Contractor of its approval or any revisions that may be required for approval. This Schedule of Values as approved by the Architect/Engineer and Owner, will be used as a basis for reviewing the Contractor's Applications for Payment, and must be revised and resubmitted as necessary to reflect adjustments to the Contract Sum by approved Contract Modifications.

#### **13.2 APPLICATIONS FOR PAYMENT**

**13.2.1 Initial Review and Submission.** The Contractor must submit to the Architect/Engineer complete and itemized Applications for Payment for Work on a monthly basis in accordance with a schedule approved by the Owner. Each Application for Payment must be consistent with the approved Schedule of Values. In order to expedite the review and approval of Applications for Payment, the Contractor may submit to and review with the Architect/Engineer and Owner a draft Application for Payment at a progress meeting prior to submitting a formal Application for Payment.

**13.2.2 Form and Contents of Application.** The form of Application for Payment must be AIA Document G702, Application and Certificate for Payment, supported by AIA Document G703,

Continuation Sheet (latest edition), or such other form as may be prescribed by the Owner. The application must be notarized and supported by sufficient data to demonstrate the Contractor's right to payment and compliance with the payment provisions of the Contract to the satisfaction of the Owner and the Architect/Engineer, such as copies of requisitions from Subcontractors and material Suppliers, partial lien waivers, releases and other documents. Each Application for Payment must reflect approved Change Orders and Contract Amendments and the Contract retainage provided for in the Contract Documents.

**13.2.3 Inclusion of Stored Materials.** Applications for Payment may include materials and equipment delivered and suitably stored at the Site for subsequent incorporation in the Work. **The Owner has no obligation or responsibility to pay for materials stored off the Site.** If determined to be in the Owner's best interest and specifically approved in writing in advance by the Owner, an Application for Payment may include materials and equipment stored off the Site at a location agreed upon in writing which is within Montgomery County. **Material stored out of Montgomery County will not be considered for payment.** Payment for materials and equipment stored on or off the Site is conditioned upon compliance by the Contractor with procedures satisfactory to the Owner to protect the Owner's interest. Payment for materials and equipment stored off the Site will, in addition, be conditioned upon the Contractor's provision of applicable insurance, storage and transportation to the Site.

**13.2.4 Exclusion of Amounts Not Payable to Subcontractors and Suppliers.** Under applicable provisions of Maryland law, payments received by the Contractor are held in trust for Subcontractors and Suppliers who have furnished labor and materials covered by an Application for Payment. Accordingly, **Applications for Payment may not include requests for payment of amounts for Work performed by a Subcontractor or Supplier that the Contractor does not intend to pay for said work.**

**13.2.5 Contract Retainage.** Until Substantial Completion of the Work, the amount of each monthly Application for Payment must include the value of each line item as indicated on the approved Schedule of Values, to the extent completed, less contract retainage of ten percent (10%). Such contract retainage will



apply whether or not the Owner is entitled to withhold additional amounts under the Contract. The Contractor has no right to receive any such retainage, or interest thereon, until Substantial Completion. Upon Substantial Completion and with the Surety's consent to the reduction in the retainage, the Contract retainage will be reduced to five percent (5%) of the Contract Sum if the manner of completion of the Work and its progress are and remain satisfactory to the Owner and the Architect/Engineer, and will remain in effect until Final Completion.

If the Project has LEED requirements, the Contract retainage will be reduced to not more than one percent (1%) of the Contract Sum if Surety consents to the reduction in the retainage and the Contractor has performed all requirements for Final Completion except for issuance, by the USGBC, of the LEED certification at the level required in the Contract Documents.

The full ten percent (10%) retainage will be reinstated if the manner of completion of the Work and its progress do not remain satisfactory to the Owner and the Architect/Engineer, or if the Surety withholds its consent, or if there is a failure to properly perform under any of the provisions of the Contract.

**13.2.6 Passage of Clear Title.** The Contractor warrants that title to all Work covered by an Application for Payment will pass to the Owner no later than the time of payment. By submitting an Application for Payment, the Contractor further warrants that all Work for which payments have previously been received from the Owner are free and clear of liens, claims, security interests or encumbrances in favor of the Contractor, Subcontractors, material Suppliers, or other persons or entities having provided labor, materials and equipment relating to the Work.

**13.2.7 Contractor's Certification.** Before the Contractor receives a progress payment, the Contractor must certify in writing that, in accordance with contractual arrangements, Subcontractors and Suppliers:

- .1 Have been paid from the proceeds of previous progress payments; and
- .2 Will be paid in a timely manner from the proceeds of the progress payment currently due.

**The foregoing certification will be deemed to**

**have been inserted into any Application for Payment from which it has been omitted.**

In the event the Contractor has not paid or does not pay as certified, such failure **constitutes a ground for Termination under Subsection 15.3.2** of the Contract.

**13.2.8 Application of Payments for Field Orders.** The Contractor shall submit its Application for Payment of Field Orders monthly to the Architect/Engineer on a separate document from the Contract Application for Payment. The Contractor can submit for partial completion of Field Orders and retainage is not applied to Field Order work.

### **13.3 CERTIFICATES FOR PAYMENT**

**13.3.1 Issuance of Certificate for Payment.** The Architect/Engineer will, within ten (10) days after receipt of the Contractor's Application for Payment, either issue to the Owner a Certificate for Payment for such amount as the Architect/Engineer determines is properly due, with a copy to the Contractor, or notify the Contractor and Owner in writing of the Architect/Engineer's reasons for withholding certification in whole or in part as provided in Subsection 13.3.3.

**13.3.2 Representation in Certificate for Payment.** The issuance of a Certificate for Payment will constitute a representation by the Architect/Engineer to the Owner, based on the Architect/Engineer's observations at the Site and the data comprising the Application for Payment, that to the best of the Architect/Engineer's knowledge, information and belief, (i) the Work has progressed to the point indicated and (ii) the quality of the Work, to the extent certified as having been completed, is in accordance with the Contract Documents. The foregoing representations are subject to an evaluation of the Work for conformance with the Contract Documents upon Substantial Completion, to results of subsequent tests and inspections, to minor deviations from the Contract Documents correctable prior to completion and to specific qualifications expressed by the Architect/Engineer, in writing in the Certificate for Payment, and are not binding upon the Owner. The issuance of a Certificate for Payment will not be a representation that the Architect/Engineer has (i) made exhaustive or continuous on-site inspections to check the quality or quantity of the Work, (ii) reviewed construction means, methods, techniques, sequences or procedures, or (iii) made examination to ascertain how or for what



purpose the Contractor has used money previously paid on account of the Contract Sum.

**13.3.3 Withholding Certification.** The Architect/Engineer may decide not to certify payment and may withhold a Certificate for Payment in whole or in part, to the extent reasonably necessary to protect the Owner, if in the Architect/Engineer's opinion the representations to the Owner required by Subsection 13.3.2 cannot be made. If the Architect/Engineer is unable to certify payment in the amount of the Application for Payment, the Architect/Engineer will notify the Contractor and Owner as provided in Subsection 13.3.1. If the Contractor and Architect/Engineer cannot agree on a revised amount, the Architect/Engineer will promptly issue a Certificate for Payment for the amount for which the Architect/Engineer is able to make such representations to the Owner. The Architect/Engineer may also decide not to certify payment or may nullify the whole or a part of a Certificate for Payment previously issued, to such extent as may be necessary in the Architect/Engineer's opinion to protect the Owner from loss because of the causes set forth in Subsection 13.3.4.

**13.3.4 Grounds for Withholding Certification.** The Architect/Engineer may withhold certification, or the Owner may withhold payment, to the extent reasonably necessary, to protect the Owner from loss on account of:

- .1 The quality of a portion, or all, of the Contractor's Work not being in accordance with the requirements of this Contract and with construction industry standards;
- .2 Claims made, or likely to be made, against the Owner or its property on account of the Contractor's performance;
- .3 Reasonable evidence that the Contractor has failed to use Contract funds, previously paid the Contractor by the Owner, to pay Contractor's Work and Project-related obligations including, but not limited to, Subcontractors, laborers and material and equipment Suppliers;
- .4 Reasonable evidence that the Work cannot be completed for the unpaid balance of the Contract Sum;
- .5 Loss by, or damage to the Owner or another contractor;

- .6 Reasonable evidence that the Contractor's rate of progress is such that, in the Owner's opinion, Substantial or Final Completion of the Work for the Project, or both, may be inexcusably delayed;
- .7 Failure to carry out the Work in accordance with the Contract Documents;
- .8 The quantity of the Contractor's Work being less than that stated in the Contractor's Application for Payment, or otherwise;
- .9 Other items which entitle the Owner to a setoff against the amounts due the Contractor; or
- .10 Failure of the Contractor to remove or bond off liens by its Subcontractors or Suppliers.

**13.3.5 Release of Certificate When Grounds Removed.** When the reasons for withholding certification are removed, the Architect/Engineer will certify payment for amounts previously withheld.

#### **13.4 PROGRESS PAYMENTS**

**13.4.1 Withholding of Payment by Owner.** The Owner may withhold payment on a Certificate for Payment in whole or in part, to the extent reasonably necessary to protect the Owner, if the Owner, based on its own Site observations, inspections or other evidence available to the Owner, does not concur with the Architect/Engineer's representations under Subsection 13.3.2 or with the Architect/Engineer's finding of removal of conditions as provided in Subsection 13.3.5. In such case the Owner will notify the Architect/Engineer and the Contractor of the reasons for withholding payment in whole or in part as permitted by this Subsection 13.4.1. If the Contractor and Owner cannot agree on a revised amount, the Owner will promptly initiate payment for an amount which the Owner determines to be appropriate. The Owner may also decide not to make payment as necessary to protect the Owner from loss because of the causes set forth in Subsection 13.3.4. In that event, Contractor must submit a revised Application for Payment for the Owner's review and approval once such causes have been remedied along with evidence reasonably satisfactory to the Owner that such causes have in fact been remedied.

**13.4.2 Payment.** Payments on Certificates for Payment which are approved by the Owner as "proper invoices" within the meaning of applicable laws and regulations will be paid within thirty (30) days after the Owner approves the Certificate for Payment.

**13.4.3 Payment Not Acceptance of Defective Work.** Issuance of a Certificate for Payment by the Architect/Engineer or the making of any progress payment by the Owner does not constitute acceptance of Work that is not in accordance with the Contract Documents.

**13.4.4 Payment Contingent on Performance.** Progress payments may be withheld to the extent the Contractor is not in full compliance with the Contract. The Owner's failure to make progress payments is not an event of default by the Owner under the Contract, nor does it give rise to the right of the Contractor to stop work.

**13.4.5 Waiver of Claims by Contractor** Acceptance of progress payments by the Contractor, a Subcontractor, Sub-subcontractor or Supplier (to the extent not previously waived) constitutes a waiver of Claims arising from any occurrence existing prior to payment, or arising from performance of the Work for which payment is made by that payee except those previously made in writing and identified by that payee as unsettled on the Application for Payment and which fully comply with the requirements of Articles 11, 12 and/or 16.

## **ARTICLE 14**

### **SUBSTANTIAL AND FINAL COMPLETION**

#### **14.1 PARTIAL OCCUPANCY OR USE**

**14.1.1 Occupancy by Owner.** The Owner may occupy or use any completed or partially completed portion of the Work prior to Substantial Completion of all of the Work pursuant to Subsection 14.1.2.

**14.1.2 Notice by Owner.** The Owner may, at any time, request the Contractor in writing to permit the Owner to occupy or use any such portion of the Work. Such partial occupancy or use may commence whether or not the portion is Substantially Complete. Consent of the Contractor to partial occupancy or use must not be unreasonably withheld.

**14.1.3 Notice by Contractor.** When the Contractor considers that a portion of the Work designated in the Contract Documents for partial

occupancy or use can be occupied or used for its intended purpose without significant interference with the Contractor's performance of the remainder of the Work, the Contractor may notify the Owner and the Architect/Engineer in writing and request an inspection of that portion and a partial Certificate of Substantial Completion. Such notice must be issued not less than ten (10) days in advance of the date that such Work will be ready for inspection. The determination whether the particular portion of the Work may be occupied for its intended use is at the Owner's sole discretion.

**14.1.4 Inspection.** Following notice by either the Owner or the Contractor, the Contractor must prepare and submit to the Architect/Engineer a list of items remaining to be completed or corrected as provided in Subsection 14.2.3. Immediately prior to such partial occupancy or use, the Owner, Contractor and Architect/Engineer will jointly inspect the area to be occupied or portion of the Work to be used in order to determine and record the condition and stage of progress of the Work.

**14.1.5 Conditions for Partial Occupancy or Use.** Unless otherwise provided in the Contract Documents or by agreement between the Owner and the Contractor, such partial occupancy or use will be subject to the Owner's assumption of responsibility for security, operation, safety, maintenance, heat, utilities, damage to the Work (other than damage caused by the Contractor) and insurance with respect to the portions of the Work to be occupied or used by the Owner. The period for correction of such portions of the Work and Warranties required by the Contract Documents will commence upon such partial occupancy or use.

**14.1.6 Partial Occupancy or Use Not Acceptance of Defective Work.** Unless otherwise agreed to in writing by the Owner, partial occupancy or use of a portion or portions of the Work does not constitute acceptance of Work not complying with the requirements of the Contract Documents.

#### **14.2 SUBSTANTIAL COMPLETION**

**14.2.1 Notice and Request for Preliminary Inspection.** When the Contractor considers that the Work is substantially complete and that items remaining to be completed or corrected can be accomplished within another thirty (30) days, the Contractor must give written notice to the Owner and the Architect/Engineer and request an inspection of the Work as provided in Subsection 14.2.3. The Contractor's notice and

request for an inspection must be accompanied by a comprehensive Punch List describing all items to be completed or corrected before final completion and the Submittals required by Subsection 14.2.2. The Contractor must proceed promptly to complete and correct items on the list. Failure to include an item on such list does not alter the Contractor's responsibility to complete all Work in accordance with the Contract Documents.

**14.2.2 Submittals on Substantial Completion.** In addition to the Punch List, the Contractor must submit the following with its request for a determination of Substantial Completion:

- .1 A use and occupancy permit;
- .2 Final test reports as provided in Subsection 10.5.7 and certificates of inspection and approval required for use and occupancy;
- .3 Fire Marshal's approval;
- .4 Approvals from, and transfer documents for, all utilities;
- .5 Warranties and Guarantees as provided in Subsection 10.2.4,
- .6 Final, approved operating and maintenance manuals for materials and systems specified in the Contract Documents;
- .7 All documents and verification of training required in accordance with any Quality Control or Commissioning Plan; and
- .8 Schedule to complete the Punch list and value of Work not yet complete.

**14.2.3 Substantial Completion Inspection and Correction.** Upon receipt of the Punch List, the Architect/Engineer will make an inspection to determine whether the Work or designated portion thereof is substantially complete and whether remaining items can be completed or corrected within thirty (30) days. The Owner may make a similar inspection. If such inspection(s) disclose any deficiency not included on the Punch List, the Architect/Engineer shall add the deficiency to the Punch list. If such inspection(s) discloses any item, whether or not included on the Punch List, which, in the opinion of the Owner or the Architect/Engineer or Owner, (i) must be completed or corrected before the Work can be occupied or used for its intended purpose, or (ii)

cannot be completed or corrected within thirty (30) days, the Architect/Engineer will so advise the Contractor, and the Contractor must promptly complete or correct such item prior to Substantial Completion.

**14.2.4 Reinspection.** If the Architect/Engineer advises the Contractor per Subsection 14.2.3 that Work is required prior to Substantial Completion, the Contractor must complete the required Work. Following the completion or correction of Work required by the Owner or the Architect/Engineer before issuance of a Certificate of Substantial Completion, the Contractor must notify the Owner and the Architect/Engineer and request another inspection by the Owner and the Architect/Engineer to determine Substantial Completion. The Contractor must submit a revised Punch List with such notice. The Architect/Engineer will promptly notify the Contractor if the Owner or the Architect/Engineer do not concur that the Work is substantially complete. In such case, the Contractor must bear the cost of any additional services of the Owner or the Architect/Engineer until the Work is determined to be Substantially Complete.

**14.2.5 Certification of Substantial Completion.** When the Owner and the Architect/Engineer concur that the Work is Substantially Complete and that Work remaining to be completed or corrected can be accomplished within a period of thirty (30) days, the Architect/Engineer will prepare a Certificate of Substantial Completion and a revised (final) Punch List. The Certificate of Substantial Completion must be signed by the Contractor, Architect/Engineer and the Owner with the Owner's signature indicating acceptance of Substantial Completion. The Certificate of Substantial Completion shall include the final Punch List and shall fix the Date of Substantial Completion and the time periods within which the Contractor must finish all items on the Punch List accompanying the Certificate.

**14.2.6 Execution and Acceptance of Certificate.** The Certificate of Substantial Completion and accompanying Punch List must be signed by the Owner and Contractor, which will constitute their written acceptance of responsibilities assigned to them in such Certificate.

**14.2.7 Conditions of Substantial Completion.** To the extent provided in the Contract Documents or in the Certificate of

Substantial Completion, the Owner, upon execution of the Certificate, will assume responsibility for security, operation, safety, maintenance, heat, utilities, damage to the Work (other than damage caused by the Contractor) and insurance.

**14.2.8 Commencement of Warranties.** Warranties required by the Contract Documents will commence on the Date of Substantial Completion of the Work unless otherwise provided in the Certificate of Substantial Completion or the Contract Documents.

**14.2.9 Delivery of Premises and Access to Work.** Upon execution of the Certificate of Substantial Completion, the Contractor will deliver custody and control of such Work to the Owner. The Owner will thereafter provide the Contractor reasonable access to such Work to permit the Contractor to fulfill the correction, completion and other responsibilities remaining under the Contract and the Certificate of Substantial Completion.

**14.2.10 Timing of Final Completion.** Unless otherwise provided in the Certificate of Substantial Completion, the Contractor must complete or correct all items included in the final Punch List within thirty (30) days after the Date of Substantial Completion.

**14.2.11 Broom Clean.** At the time of Substantial Completion, in addition to removing rubbish and leaving the building "broom clean," the Contractor must replace any broken or damaged materials, remove stains, spots, marks and dirt from decorated Work, clean all fixtures, vacuum all carpets and wet mop all other floors, and comply with such additional requirements, if any, which may be specified in the Contract Documents.

### **14.3 FINAL COMPLETION**

**14.3.1 Notice and Request for Final Inspection.** When the Contractor has completed or corrected all items on the final Punch List and considers that the Work is complete and ready for final acceptance, the Contractor must give written notice to the Owner and the Architect/Engineer and request a final inspection of the Work as provided in Subsection 14.3.2. The Contractor's notice and request for a final inspection must be accompanied by a final Application for Payment and the Submittals required by Subsection 14.3.3.

**14.3.2 Final Inspection and Certificate of Final Completion.** Upon receipt of the

Contractor's notice and request for final inspection, the Owner and the Architect/Engineer will promptly make such inspection and, when the Owner and the Architect/Engineer concur that the Work has been fully completed and is acceptable under the Contract Documents, the Architect/Engineer will issue a Certificate of Final Completion to the Owner. The Contractor's notice and request for final inspection constitutes a representation by the Contractor to the Owner that the Work has been completed in full and strict accordance with terms and conditions of the Contract Documents. The Architect/Engineer will promptly notify the Contractor if the Owner or the Architect/Engineer do not concur that the Work is finally complete. In such case, the Contractor complete and/or correct the outstanding Work and must bear the cost of any additional services of the Owner or the Architect/Engineer until Final Completion is achieved.

**14.3.3 Final Submittals.** Neither final payment nor any remaining retained percentage will become due until the Contractor submits the following documents to the Architect/Engineer:

- .1 An affidavit that payrolls, bills for materials and equipment, and other indebtedness connected with the Work for which the Owner or the Owner's property might be responsible or encumbered (less amounts withheld by Owner), have been paid or otherwise satisfied, submitted on AIA Document G706, Affidavit of Payment of Debts and Claims (latest edition) or such other form as may be prescribed by the Owner;
- .2 A release or waiver of liens on behalf of the Contractor and a similar release or waiver on behalf of each Subcontractor and Supplier, accompanied by AIA Document G706A, Affidavit of Release of Liens (latest edition) or such other form as may be prescribed by the Owner;
- .3 A written statement that the Contractor knows of no substantial reason that the insurance will not be renewable to cover the period required by the Contract Documents;
- .4 Consent of Surety to final payment, submitted on AIA Document G707

(latest edition) or other form prescribed by the Owner;

- .5 Other data required by the Owner establishing payment or satisfaction of obligations, such as receipts, releases and waivers of liens, claims, security interests or encumbrances arising out of the Contract, to the extent and in such form as may be prescribed by the Owner;
- .6 A certified building location survey and as-built site plan in the form and number required by the Contract Documents;
- .7 All warranties and bonds required by the Contract Documents;
- .8 Record Documents as provided in Subsection 2.4.5 and return of Contract Documents as provided therein;
- .9 Attic stock items as required by the Contract Documents; and
- .10 As applicable, documentation of approval by the Montgomery County Department of Permitting Services (DPS) of all Storm Water Management (SWM) work as to allow close-out of the SWM Permit. DPS approval will be based on satisfying all DPS Permit requirements including the submission of acceptable as-built SWM drawing and other required SWM documents.

**14.3.4 USGBC LEED Certification Required for Final Completion.** If the Project has LEED requirements, Final Completion will not be granted until the USGBC has issued the LEED certification for the Project at the level required in the Contract Documents or until the USGBC has determined that there are no contractor-responsible LEED deficiencies.

#### **14.4 FINAL ACCEPTANCE AND PAYMENT**

**14.4.1 Final Certificate for Payment.** The Architect/Engineer and the Owner will promptly review the final submittals, and after notice from the Owner that all final submittals are acceptable and that the Contract has been fully performed, the Architect/Engineer will issue a final Certificate for Payment. The Contractor's Application for final Payment constitutes a further representation that the conditions listed

in Subsections 14.3.2 and 14.3.3 as precedent to the Contractor's being entitled to final payment have been fulfilled.

**14.4.2 Delay in Final Completion.** If, after Substantial Completion of the Work, Final Completion cannot be achieved and is materially delayed through no fault of the Contractor or as a result of issuance of Contract Modifications issued after Substantial Completion, and the Architect/Engineer so confirms, the Owner will, upon Application for Payment by the Contractor and Certification of Payment by the Architect/Engineer, and without terminating the Contract, make payment of the balance due for that portion of the Work fully completed and accepted, provided that the remaining Contract balance for Work not fully completed or corrected after making such payment is not less than the greater of (i) the amount of the retainage stipulated in the Contract Documents and currently being retained or (ii) the Owner's estimate of the amount necessary to complete and correct any Work not fully completed or corrected after making such payment. Provided further that if bonds have been furnished, the written consent of Surety to payment of the balance due for that portion of the Work fully completed and accepted is submitted by the Contractor to the Architect/Engineer prior to the Architect/Engineer's issuance of the Certificate for Payment. Such payment will be subject to the same terms and conditions governing final payment.

**.1 Additional Work requested by the Owner after Substantial Completion.** If the Owner directs that Work be performed beyond the Work specified in the Contract but within the general scope of the Contract (Change Order or Field Order Work) after Substantial Completion, the Contractor is entitled to an increase in the Contract Time equal to the time required to perform the additional Work, but is still liable to the Owner for any prior unexcused delays.

**14.4.3 Final Payment.** Final payment, constituting the entire unpaid balance of the Contract Sum and other amounts payable to the Contractor, less any amounts withheld by the Owner under Subsection 14.4.4, will be made by the Owner to the Contractor not more than thirty (30) days after:



- .1 The Contract has been fully performed by the Contractor except for the Contractor's responsibility to correct nonconforming Work as provided in Subsection 10.2.2 and to satisfy other requirements, if any, which necessarily survive final payment; and
- .2 A final Certificate for Payment has been issued by the Architect/Engineer and approved by the Owner as a "proper invoice" within the meaning of applicable laws and regulations.

**14.4.4 Withholding by Owner from Final Payment.** The Owner may deduct such sums from final payment as may be due on account of actual or Liquidated Damages or other unsettled obligations under the Contract Documents, such as the acceptance of defective or nonconforming Work and costs payable by the Contractor.

**14.4.5 Waiver of Claims by Owner.** The making of final payment does not constitute a waiver of claims by the Owner arising from the Contractor's performance of the Work including but not limited to:

- .1 Liens, claims, security interests or encumbrances arising out of the Contract and unsettled;
- .2 Failure of the Work to comply with the requirements of the Contract Documents;
- .3 Terms of Guarantees or Warranties required by the Contract Documents; and
- .4 Unresolved claims or disputes.

**14.4.6 Waiver of Claims by Contractor.** Acceptance of final payment by the Contractor, a Subcontractor, Sub-subcontractor or Supplier (to the extent not previously waived) constitutes a waiver of Claims arising from any occurrence existing prior to final payment, or arising from, performance of the Work for which final payment is made by that payee except those previously made in writing and identified by that payee as unsettled on the final Application for Payment and which fully comply with the provisions of Articles 11, 12 and 16.

## **ARTICLE 15**

### **RIGHTS AND REMEDIES**

#### **15.1 OWNER'S RIGHTS AND REMEDIES**

**15.1.1 Special and Additional Testing and Inspection.** The Owner, on its own initiative or upon the recommendation of the Architect/Engineer, has the right to require additional inspection or testing of the Work as provided in Section 10.5.

**15.1.2 Rejection of Nonconforming Work.** The Owner has the right and the Architect/Engineer has authority to reject Work which does not conform to the Contract Documents as provided in Subsection 10.6.1 and to require its correction or replacement as provided in Subsection 10.6.2 unless accepted by the Owner under Subsection 10.6.3.

**15.1.3 Withholding of Certificates and Withholding of Payments.** The Architect/Engineer has the authority to withhold a Certificate for Payment in accordance with Subsections 13.3.3 and 13.3.4. The Owner has the right to withhold payment on a Certificate for Payment as provided in Subsections 13.3.4 and 13.4.1.

**15.1.4 Additional Bonds and Insurance.** The Owner has the right to require the Contractor to furnish additional bonds as provided in Subsections 14.3.4 and 17.1.3 and additional insurance as provided in Subsection 17.4.4.

**15.1.5 Removal of Superintendent, Personnel, Subcontractors or Suppliers.** The Owner has the right to require the Contractor to remove and replace the Contractor's Superintendent, Project Manager, Quality Control Manager and/or any of the Contractor's key project personnel, at no additional cost to the Owner, if the Contractor fails to maintain good order and discipline at the Site under Subsection 5.3.3, if any key personnel proves to be unsatisfactory under Subsection 5.4.2, or if personnel are not properly qualified as required by Subsection 5.5.5. The Owner has the right to require the removal and replacement of any Subcontractor or Supplier as provided in Subsections 6.1.5 and 6.1.6.

**15.1.6 Stopping or Suspending the Work.** The Owner has the right to order the Contractor to stop the Work as provided in Subsection 11.4.1 or to suspend the Work as provided in Subsection 11.4.2.

**15.1.7 Correction of Defective Work by Owner.** The Owner has the right to correct rejected or nonconforming or defective Work as provided in Subsection 10.6.6.

**15.1.8 Cleaning Up.** If the Contractor fails to clean up as provided in the Contract



Documents, the Owner may do so as provided in Subsection 5.6.7.

**15.1.9 Owner Takeover.** If the Contractor defaults or otherwise neglects to carry out or complete the Work or a designated portion thereof in accordance with the Contract Documents, whether before or after Substantial Completion, the Owner may include with any notice of default in the performance of such Work, notice of the Owner's intent to remedy the default and perform the Work itself or with other forces, if not remedied by the Contractor within the time specified in the notice, in which case an appropriate Change Order will be issued deducting from payments then or thereafter due the Contractor the cost of correcting the deficiencies or completing such Work, including compensation for the Owner's and the Architect/Engineer's additional services made necessary by such default, neglect or failure. If payments then or thereafter due the Contractor are not sufficient to cover such amounts, the Contractor must pay the difference to the Owner upon written demand.

## **15.2 TERMINATION BY OWNER FOR CONVENIENCE**

**15.2.1 Owner's Right to Terminate for Convenience.** The Owner may, at any time, terminate the Contract or any portion thereof or of the Work for the Owner's convenience and without cause.

**15.2.2 Action by Contractor Upon Notice.** Upon receipt of written notice from the Owner of termination, the Contractor must:

- .1 Cease operations as directed by the Owner in the notice and, if required by the Owner, participate in an inspection of the Work with the Owner and the Architect/Engineer to record the extent of completion thereof, to identify the Work remaining to be completed or corrected, and to determine what temporary facilities, tools, equipment and construction machinery are to remain at the Site pending completion of the Work;
- .2 Complete or correct the items directed by the Owner, and take actions necessary, or that the Owner may direct, for the protection and preservation of any stored materials and equipment and completed Work;
- .3 Unless otherwise directed by the Owner, remove its tools, equipment

and construction machinery from the Site, and

- .4 Except as directed by the Owner, terminate all existing subcontracts and purchase orders related to the Work and enter into no further subcontracts or purchase orders therefor.

**15.2.3 Action by Owner Following Notice.** Following written notice from the Owner of termination, the Owner may:

- .1 Take possession of the Site and of all materials and equipment thereon, and at the Owner's option, such temporary facilities, tools, construction equipment and machinery thereon owned or rented by the Contractor that the Owner elects to utilize in completing the Work;
- .2 Accept assignment of subcontracts and purchase orders as provided in Section 6.4, and
- .3 Complete the Work by whatever reasonable method the Owner may deem expedient.

**15.2.4 Contract Adjustments.** In case of termination for the Owner's convenience, the Contractor will be entitled to compensation only for the following items:

- .1 Payment for acceptable Work performed up to the date of termination;
- .2 The costs of preservation and protection of the Work if requested to do so by the Owner;
- .3 The cost of terminating the following contracts including:
  - (i.) Purchased materials but only if not returnable and provided to the Owner, or the restocking or return charge, if any, if returnable at the Owner's written election;
  - (ii.) Equipment rental contracts if not terminable at no cost but not to exceed an amount equal to thirty (30) days rental;
- .4 Documented transportation costs associated with removing Contractor-owned equipment;
- .5 Documented demobilization and close-out costs; and

- .6 Overhead and profit on the foregoing not to exceed ten (10%) percent.

The Contractor will not be compensated for the cost of terminating subcontracts which must be terminable at no cost to the Owner if the Contract is terminated. The Contractor will not be compensated for the cost of any idled employees unless the employee is under a written employment contract entitling the employee to continued employment after termination of the Contract and the employee cannot be assigned to other work provided that in all events the Contractor's costs must be limited to thirty (30) days of employment costs from the date of the notice of termination. **The Contractor is not entitled to any other costs or compensation (including lost or expected profit, uncompensated overhead or related expenses, or the cost of preparing and documenting its compensable expenses under this Subsection 15.2.4 as a consequence of the Owner's termination of the Contract for convenience. The Contractor conclusively and irrevocably waives its right to any other compensation or damages (compensatory or punitive) arising from termination of the Contract.** If the Owner and the Contractor are unable to agree upon the amounts specified in this subsection, the Contractor may submit a Claim as provided in Article 16. The Claim must be limited to resolution of the amounts specified in Subsections 15.2.4.1, 15.2.4.2, 15.2.4.3 and 15.2.4.4 of this Subsection 15.2.4. **No other cost, damages or expenses may be claimed or paid to the Contractor or considered as part of the Claim, the same being hereby conclusively and irrevocably waived by the Contractor.** Any such Claim must be filed with the Director within thirty (30) days of the termination of the Contract and must contain a written statement setting forth the specific reasons and supporting calculations as to the amounts the Contractor claims to be entitled to under this Subsection, all with supporting documentation of all cost claimed as a result of the termination of the Contract.

**15.2.5 Obligations to Continue.** The Contractor's obligations surviving final payment under the Contract, including without limitation those with respect to insurance, indemnification, and correction of Work which has been completed at the time of termination, remains effective notwithstanding termination for convenience of the Owner.

## 15.3 TERMINATION BY THE OWNER FOR CAUSE

**15.3.1 Owner's Right to Terminate for Cause.** The Owner may terminate the Contract for cause for any of the reasons set forth in the following Subsection 15.3.2.

**15.3.2 Grounds for Termination.** The Owner has the right to terminate the Contract for cause if the Contractor:

- .1 Fails to supply adequate properly skilled workers or proper materials;
- .2 Fails to make payment to Subcontractors or Suppliers for materials or labor in accordance with the respective agreements between the Contractor and the Subcontractors or Suppliers;
- .3 Fails to comply with any laws, ordinances, or rules, regulations or orders of a public authority having jurisdiction;
- .4 Fails to perform the Work in accordance with the Contract Documents or otherwise breaches any provision of the Contract Documents;
- .5 Files for bankruptcy (voluntary or involuntary);
- .6 Is guilty of an anticipatory breach or repudiation of the Contract;
- .7 Fails to make satisfactory progress in the prosecution of the Contract; or
- .8 Endangers the performance of this Contract.

**15.3.3 Notice of Termination.** The Director may terminate the Contract, in whole or in part, whenever the Director determines that sufficient grounds for termination exist as provided in Subsection 15.3.2. The Director will provide the Contractor with a written notice to cure the default. If the default is not cured, the termination for default is effective on the date specified in the Director's written notice. However, if the Director determines that default contributes to the curtailment of an essential service or poses an immediate threat to life, health, or property, the Director may terminate the Contract immediately upon issuing oral or written notice to the Contractor without any prior notice or opportunity to cure. In addition to any other remedies provided by law or the Contract, the Contractor must compensate the Owner for additional costs that foreseeably would be

incurred by the Owner, whether the costs are actually incurred or not, to obtain substitute performance. A termination for default is a termination for convenience if the termination for default is later found to be without justification.

**15.3.4 Action by Contractor and Owner.** Upon termination for cause, the Contractor must take those actions described in Subsection 15.2.2, and the Owner may take those actions described in Subsection 15.2.3, subject to the prior rights of the Contractor's Surety.

**15.3.5 Suspension of Payments.** When the Owner terminates the Contract for cause, the Contractor is not entitled to receive further payment until the Work is completed and the costs of completion have been established.

**15.3.6 Adjustments and Payments.** If the unpaid balance of the Contract Sum less amounts which the Owner is entitled to offset from the unpaid Contract balance including actual or Liquidated Damages, exceeds the costs of completing the Work, including compensation for the Owner's and the Architect/Engineer's services made necessary thereby, such excess will be paid to the Contractor or Surety, as directed by the Surety. If such costs exceed the unpaid Contract balance, the Contractor must pay the difference to the Owner upon written demand. This obligation for payment survives termination of the Contract.

**15.3.7 Right to Take Other Than Low Bid.** In completing the Work following termination for cause or for convenience, the Owner is not required to solicit competitive bids or to award completion work to the lowest bidder, but may obtain such completion work and related services on the basis of sole source procurement and negotiated compensation.

**15.3.8 Termination As If For Convenience.** If, after termination of the Contract, it is determined that the Owner did not have sufficient grounds to terminate for cause, the rights and obligations of the parties will be the same as if the termination had been issued for the convenience of the Owner, and the provisions of Section 15.2, including Subsection 15.2.4, will apply.

#### **15.4 CONTRACTOR'S NO RIGHT TO STOP WORK**

The Contractor has no right to stop Work as a consequence of non-payment. In the event of any disagreement between the Contractor and Owner involving the Contractor's entitlement to

payment, the Contractor's only remedy is to file a Claim in accordance with Article 16. The Contractor must diligently proceed with the Work pending resolution of the Claim, Dispute and/or Dispute Appeal. If, however, an Application for Payment has been approved for payment by the Owner, and the Owner fails to make payment within sixty (60) days of the approval for payment by the Owner, the Contractor may upon ten (10) days written notice to the Owner, stop work if payment is not made by the Owner within ten (10) days following the notice.

### **ARTICLE 16**

#### **CLAIMS, DISPUTES, AND DISPUTE APPEALS**

##### **16.1 CLAIM**

**A Claim is a written request by the Contractor that seeks the payment of money, an adjustment of time, an adjustment or interpretation of a Contract provision, or other relief arising under or relating to the Contract. Claims include all requests for additional Contract Time and/or Contract Sum in accordance with Articles 11 and/or 12.**

**A Claim must be filed, in writing, with the Contract Administrator within the time and containing the information required in:**

- .1 Section 11.6, as to an excusable or compensable delay;
- .2 Subsection 12.2.5, as to a unilateral Change Order;
- .3 Subsection 12.5.1, as to a Constructive Change;
- .4 Subsection 12.3.5 as to a unilateral Field Order;
- .5 Subsections 12.4.3, 12.4.4 and 12.5.1 as to differing Site and Structural conditions; and
- .6 Subsection 15.2.4 as to a disagreement arising from termination of the Contract.

As to a disagreement over interpretation of a Contract provision or the Contract Documents, the Contractor must file a Claim within ten (10) days of issuance or statement of the contrary interpretation by Owner.

As to any other Claim arising under or relating to the Contract, the Work or the Project, the Contractor must file a Claim within ten (10) days of the event giving rise to the Claim, unless

otherwise specified in the Contract Documents.

A Claim will be deemed to have been conclusively waived by the Contractor if it is not filed within the specified time or it does not contain the required information.

**16.2 CONTRACT ADMINISTRATOR'S DECISION ON CONTRACTOR'S CLAIM**

The Contract Administrator is responsible for issuing decisions on Claims. The Contract Administrator's final decision on a Claim shall be considered an event giving rise to a Dispute and the Contractor must file any Dispute within the time period stated in Section 16.3 from the date of the Contract Administrator's final decision.

**16.3 DISPUTE**

A Dispute means an unresolved Claim. If a Contractor's Claim is denied, in whole or in part, by the Contract Administrator, the Contractor must file any Dispute the Contractor may wish to take, with the Director, within thirty (30) days of the event giving rise to the Dispute. The Contractor waives any Dispute not timely filed. The Director must dismiss a Dispute that is not timely filed.

**16.4 APPEAL OF THE DIRECTOR'S DECISION (DISPUTE APPEAL).**

The Director must decide a Dispute within 45 days after receiving the Dispute unless the Contractor agrees to extend the time for a decision. If the Director denies a Dispute, in whole or in part, the Contractor may file a Dispute Appeal with the Chief Administrative Officer for Montgomery County, Maryland. The Contractor must file a Dispute Appeal within 30 days after receiving the Director's decision, or if no decision is rendered by the Director within 45 days, within 75 days after submitting the Dispute. The Dispute Appeal will thereafter be resolved as provided by Section 11B-35 of the Montgomery County Code and Section 14.2 of the Montgomery County Procurement Regulations or their respective successor provisions. Article 16 is the Contractor's sole and exclusive remedy for resolution of any and all Disputes arising under or relating in any way to the Contract, the Work or the Project. The deadlines set forth in Article 16 and in the Montgomery County Code and Procurement Regulations are jurisdictional and if not complied with will result in denial and

**dismissal of the Dispute and Dispute Appeal.**

**16.5 INCORPORATION OF THE MONTGOMERY COUNTY CODE AND PROCUREMENT REGULATIONS**

All Disputes must be decided under the Montgomery County Code and the Montgomery County Procurement Regulations which is the Contractor's sole and exclusive remedy for resolving Disputes under this Contract.

**ARTICLE 17**

---

**INSURANCE AND BONDS**

**17.1 PERFORMANCE AND PAYMENT BONDS**

**17.1.1 Requirement for Bonds.** For construction Contracts exceeding one hundred thousand dollars (\$100,000.00) in amount, the Contractor must furnish a performance bond and a payment bond, each in an amount equal to ninety five percent (95%) of the Contract Sum as security for the faithful performance of the Contract and as security for the payment of all persons performing labor and furnishing materials in connection with the Work; for construction Contracts exceeding fifty thousand dollars (\$50,000.00) but not exceeding one hundred thousand dollars (\$100,000.00) the Contractor must furnish a performance bond and a payment bond, each in an amount equal to fifty percent (50%) of the Contract Sum as security for the faithful performance of the Contract and as security for the payment of all persons performing labor and furnishing materials in connection with the Work. The performance bond and the payment bond must be in such form as the Owner may require and must be delivered to the Owner prior to execution of the Contract by the Owner. The Surety must be acceptable to the Owner and must be approved to transact business in the State of Maryland. No bond will be required for Contracts under fifty thousand dollars (\$50,000.00). **The Contractor shall also be required, at no cost to the Owner, to provide Performance and Payment Bonds required by any utilities for performance of any utility Work or Work on utility lines or within utility easements.**

**17.1.2 Copies to be Furnished to Beneficiaries.** Upon the request of any person or entity appearing to be a potential beneficiary of bonds covering payment of obligations arising under the Contract, the Contractor must promptly furnish a copy of the bonds to such person or entity.

**17.1.3 Owner's Right to Require Additional Bonds.** The Owner has the right to require the Contractor, or any Subcontractor or Sub-subcontractor under any contract over \$50,000.00 in amount, to furnish such additional bonds as are reasonably required by the Owner, the cost of which will be borne by the Owner, unless otherwise specified in the Contract Documents.

## **17.2 CONTRACTOR'S LIABILITY INSURANCE**

**17.2.1 Requirement for Insurance.** The Contractor must purchase from and maintain with a company or companies licensed to do business in the State of Maryland such insurance as will protect the Contractor from claims set forth in Subsection 17.2.2 which may arise out of or result from the Contractor's operations under the Contract and for which the Contractor may be legally liable, whether such operations be by the Contractor or by a Subcontractor, Supplier, or Sub-subcontractor or by anyone directly or indirectly employed by any of them, or by anyone for whose acts any of them may be liable.

**17.2.2 Scope of Coverage.** The scope of the Contractor's liability insurance coverage must include the following:

- .1 Claims under workers' compensation, disability benefit and other similar employee benefit acts which are applicable to the Work to be performed;
- .2 Claims for damages because of bodily injury, occupational sickness or disease, or death of the Contractor's employees;
- .3 Claims for damages because of bodily injury, sickness or disease, or death of any person other than the Contractor's employees;
- .4 Claims for damages from personal injury which are sustained (i) by a person as a result of an offense directly or indirectly related to employment of such person by the Contractor, or (ii) by another person;
- .5 Claims for damages, other than to the Work itself, because of injury to or destruction of tangible property, including loss of use resulting therefrom;

.6 Claims for damages because of bodily injury, death of a person or property damage arising out of ownership, maintenance or use of a motor vehicle; and

.7 Claims for which the Contractor is obligated to indemnify others under the requirements of Section 8.4.

**17.2.3 Additional Insureds.** The Owner and the Architect/Engineer and any additional consultants of either who are identified to the Contractor in writing must be included as additional insureds by endorsement to the policies.

**17.2.4 Insurance Coverage and Limits of Liability.** The insurance coverage and limits required by Subsections 17.2.1 and 17.2.2 must be written for not less than limits of liability specified in the Contract Documents or required by law, whichever is greater.

**17.2.5 Duration of Coverage.** Coverages, whether written on an occurrence or claims-made basis, must be maintained without interruption from Notice to Proceed until Final Completion or subsequent termination of any coverage required by the Contract Documents to be maintained after final payment.

**17.2.6 Notice of Cancellation, Expiration or Non-renewal.** The insurance policies required by this Section 17.2 must contain a provision that coverages afforded under the policies will not be canceled or allowed to expire until at least sixty (60) days prior written notice has been given to the Owner. The Certificates of Insurance and certified copies of the policies furnished by the Contractor to the Owner under the following Subsection 17.2.7 must evidence compliance with this requirement. The Contractor must promptly furnish to the Owner any information of which it is aware concerning reduction or lapse including non-renewal of coverage.

**17.2.7 Certificates and Policies of Insurance.** Certificates of Insurance acceptable to the Owner and evidencing compliance with this Section 17.2 must be filed with the Owner prior to commencement of the Work. **At the request of the Owner throughout the Contract term, the Contractor must promptly submit certified copies of such policies.** If any of the insurance coverages are required to remain in force after final payment, additional certificates evidencing continuation of such



coverage must be submitted with the Contractor's final Application for Payment.

**17.2.8 Acceptance or Approval by Owner.** The form and substance of all insurance policies required to be obtained by the Contractor are subject to the approval of the Owner.

### **17.3 PROPERTY INSURANCE**

**17.3.1 Owner's Coverage Limited.** The Owner does not provide property insurance coverage for the Work or the Project. The Owner's property insurance specifically excludes coverage of projects under construction, renovations or supplies, materials and equipment stored at the Site for incorporation into the Work.

**17.3.2 Builder's All Risk Property Insurance Coverage to Be Provided by Contractor.** The Contractor must provide Builder's All Risk Property Insurance with a company or companies lawfully authorized to do business in the State of Maryland. This insurance must include the interests of the Owner, the Contractor and its Subcontractors, Sub-subcontractors and Suppliers.

**17.3.3 Policy Form.** Builder's All Risk Property Insurance must be written on a Risk of Loss basis (Special Coverage) including collapse and debris removal, on a Completed Value form of policy. Cost for reasonable compensation for the Architect/Engineer's services and expenses required as a result of such insured loss must be included as part of the amount of insurance.

**17.3.4 Amount of Coverage.** The Builder's All Risk Property Insurance policy furnished by the Contractor must be written in an amount equal to one hundred percent (100%) of the insurable value of the Work as well as subsequent modifications thereto for the entire Work at the Site.

**17.3.5 Scope of Coverage.** The Builder's All Risk Property Insurance policy furnished by the Contractor must include coverage for items of labor and materials in place or to be used as part of the permanent Work, including surplus materials, temporary structures, and miscellaneous materials and supplies incidental to the Work.

**17.3.6 Work Stored or in Transit.** Unless otherwise provided in the Contract Documents, the Builder's All Risk insurance must cover portions of the Work stored off the Site pursuant to the written approval of the Owner at the value

established in the approval or if not established in the approval notice, at one hundred percent (100%) of the replacement value, and also portions of the Work in transit.

**17.3.7 Duration of Builder's All Risk Property Insurance Coverage.** Such Builder's All Risk Insurance must be maintained, unless otherwise provided in the Contract Documents or otherwise agreed in writing by all persons and entities who are beneficiaries of such insurance, until Substantial Completion.

**17.3.8 Notice of Cancellation, Expiration or Non-renewal.** The Builder's All Risk policy furnished by the Contractor must contain a provision that coverages afforded under the policy will not be cancelled or allowed to expire until at least sixty (60) days' prior written notice has been given to the Owner. The policies and Certificates of Insurance furnished by the Contractor to the Owner under the following Subsection 17.3.9 must evidence compliance with this requirement. The Contractor must promptly furnish to the Owner any information of which it is aware concerning reduction or lapse including non-renewal of coverage.

**17.3.9 Certificates and Policies of Insurance.** Certificates of Insurance acceptable to the Owner and evidencing compliance with this Section 17.3 must be filed with the Owner along with a certified copy of the Builder's All Risk policy prior to commencement of the Work and as requested by the Owner, during the Work. If the insurance coverages are required to remain in force after final payment, additional certificates evidencing continuation of such coverage must be submitted with the Contractor's final Application for Payment.

**17.3.10 Absence of Coverage.** If the Contractor is unable to purchase such insurance required by the Contract and with all of the coverages described in this Article 17, and in the amounts specified in the Contract Documents, the Contractor must so inform the Owner in writing prior to commencement of the Work. The Owner may then obtain insurance which will protect its interests and those of the Contractor, Subcontractors, Sub-subcontractors and Suppliers in the Work, and the cost thereof will be charged to the Contractor. If the Owner is damaged by the failure or neglect of the Contractor to purchase or maintain insurance as described above, without so notifying the Owner, then the Contractor must bear all reasonable costs properly attributable thereto.

### **17.4 OTHER INSURANCE**



**17.4.1 Owner's Liability Insurance.** The Owner is responsible for purchasing and maintaining its own liability insurance and, at its option, may purchase or self-insure and maintain other insurance to protect itself against claims which may arise from operations under the Contract. The Contractor is not responsible for purchasing and maintaining such Owner's liability insurance unless specifically required by the Contract Documents.

**17.4.2 Boiler and Machinery Insurance.** The Owner, at its option, after Substantial Completion or acceptance of a portion of the Work, and until final acceptance, may require the Contractor to extend or purchase boiler and machinery insurance to cover such boilers and machinery, the cost of which will be borne by the Contractor.

**17.4.3 Insurance Covering Partial Use or Occupancy.** Partial occupancy or use in accordance with Section 14.1 will not commence until the insurance company or companies providing property insurance have consented to such partial occupancy or use by endorsement or otherwise. The Owner and the Contractor will take reasonable steps to obtain consent of the insurance company or companies and will not, without mutual written consent, take any action with respect to partial occupancy or use that would cause cancellation, lapse or reduction of insurance.

**17.4.4 Other Insurance Required by Owner.** The Owner has the right to require the Contractor, or any Subcontractor or Sub-subcontractor, to furnish such additional insurance coverage as is reasonably required by the Owner. The additional costs of such insurance will be borne by the Owner, unless otherwise specified in the Contract Documents, who will issue an appropriate Modification to the Contract adjusting the Contract Sum. If the Contractor disagrees with the adjustment made in the Contract Sum, the Contractor must file a Claim as and when provided in Article 16. A claim for an increase in the Contract Sum, to be valid, must further be documented and calculated as specified in Subsection 12.2.2. **Failure of the Contractor to file a Claim as and when specified in this Subsection is deemed a waiver of any claim by the Contractor to an adjustment in the Contract Sum.**

## **17.5 GENERAL PROVISIONS**

**17.5.1 Adjustment of Insured Losses by Owner.** A loss insured under the Builder's All

Risk insurance will be adjusted by the Owner and the Contractor and made payable to the Owner as fiduciary for the insureds, as their interests may appear.

**17.5.2 Distribution of Proceeds by Owner and Contractor.** Upon the settlement of an insured loss, the Owner will deposit in a separate account proceeds received, which the Owner will distribute in accordance with such agreement as the parties in interest may reach, or in accordance with a final determination under the disputes provisions of Article 16. The Owner, during the pendency of any such dispute, in its discretion, may apply the proceeds to the reconstruction of the Work, and to payment of the Owner's extended performance costs including but not limited to Liquidated Damages, A/E and staff costs and loss of use costs. The Contractor must pay Subcontractors their just shares of insurance proceeds received by the Contractor, and by appropriate written agreements must require Subcontractors to make payments to their Sub-subcontractors in similar manner.

## **ARTICLE 18**

### **NONDISCRIMINATION IN EMPLOYMENT**

The Contractor agrees to comply with the nondiscrimination in employment policies and provisions prohibiting unlawful employment practices in Montgomery County contracts as required by Section 11B-33 and Section 27-19 of the Montgomery County Code, as well as all other applicable state and federal laws and regulations regarding employment discrimination. The Contractor assures the Owner that, in accordance with applicable law, it does not, and agrees that it will not discriminate in any manner on the basis of race, color, religious creed, ancestry, national origin, age, sex, marital status, disability, or sexual orientation. The Contractor must bind its Subcontractors to the provisions of this Article 18; and by appropriate written agreements must require subcontractors to similarly bind their sub-subcontractors to the provisions of this Article 18.

## **ARTICLE 19**

### **STATUTORY REQUIREMENTS**

#### **19.1 ETHICS REQUIREMENTS/POLITICAL CONTRIBUTIONS**

The Contractor must comply with the ethics provisions contained in chapters 11B and

19A, Montgomery County Code, which include the following: (i) a prohibition against making or offering to make certain gifts, Section 11B-51(a); (ii) a prohibition against kickbacks, Section 11B-51(b); (iii) a prohibition against a person engaged in a procurement from employing or offering to employ a public employee, Section 11B-52(a); (iv) a prohibition against a contractor that is providing a recommendation to Montgomery County from assisting another party or seeking to obtain an economic benefit beyond payment under the contract Section 11B-52(b); (v) a restriction on the use of confidential information obtained in performing a contract, Section 11B-52(c); (vi) a prohibition against contingent fees, Section 11B-53. Furthermore, the Contractor specifically agrees not to violate Sections 11B-51, 11B-52, 11B-53, 19A-12 and/or 19A-13 of the Montgomery County Code. In addition, the Contractor must comply with the political contribution reporting requirements currently codified under Title 14 of Article 33 of the Annotated Code of Maryland.

## 19.2 MINORITY CONTRACTING

**19.2.1 Policy.** Pursuant to Section 11B-57 of the Montgomery County Code, it is the policy of the Owner to actively recruit minority businesses to provide goods and services for the performance of governmental functions. Minority-owned businesses are described in Montgomery County law as Minority/Female/Disabled-owned businesses (MFD). MFD businesses include certain non-profit entities organized to promote the interest of persons with a disability demonstrating (on a contract-by-contract basis) that at least 51% of the persons used by the non-profit entity to perform the services or manufacture the goods contracted for by the Owner, are persons with a disability. MFD firms also include firms that are 51% owned, controlled and managed by one or more member(s) of socially or economically disadvantaged minority groups, which include: African-Americans (not of Hispanic origin), Hispanic Americans, Native Americans, Asian Americans, women and the mentally or physically disabled.

**19.2.2 Applicable Regulations.** Montgomery County Procurement Regulations, Section 7, "Minority Contracting," (COMCOR 11B.00.01.07 *et seq.*) delineate the procedure to be followed. A copy of Section 7 of the Procurement Regulations is available on request.

**19.2.3 Minority Business Addendum.** The Minority Business Addendum, PMMD 91, is incorporated into and made a part of the Contract.

## 19.3 AMERICAN STEEL

**19.3.1 American Steel.** To the extent required in Md. Code Ann., State Fin. & Proc., §17-303 (2006 Repl. Vol.), Contractor must use or supply only American steel products; provided, however, Contractor must notify Owner if Owner is entitled to an exception under Section 17-303 because:

- .1 The price of American steel products is not reasonable as provided in Md. Code Ann., State Fin. & Proc., §17-304 (2006 Repl. Vol.);
- .2 American steel products are not produced in sufficient quantity to meet the requirements of the Contract; or
- .3 The purchase of American steel products would be inconsistent with the public interest.

**Should Contractor fail to notify Owner as required by this Subsection, Owner is entitled to a reduction in the total cost of the Contract by an amount equal to the savings which would have resulted had Owner not bought American steel products.**

## 19.4 PREVAILING WAGE

### 19.4.1 State of Maryland

If the funds for the Project are less than fifty percent (50%) State money, the Contractor is excused from performing all acts required of a Contractor under Md. Code Ann., State Fin. & Proc., §17-201 *et seq.* (2006 Repl. Vol.), otherwise the Contractor must perform all acts required by that law and refrain from doing all acts prohibited by that law, unless therein exempted or excluded. It is the Contractor's responsibility to determine from the Owner the percentage of State money allocated to the Work.

### 19.4.2 Montgomery County

The Contractor and all tiers of Subcontractors and Sub-subcontractors must comply with the Prevailing Wage Law contained in Chapters 11B-33C, and 20-75 of the Montgomery County Code and the requirements set forth below:

- .1 Prevailing wage means the wage rate paid by employers that is determined

by a governmental authority, based upon a particular geographic area, for a given class of labor and type of project;

- .2 The purpose of a prevailing wage is to ensure that construction workers who work on public work contracts are paid the going rate for their services.
- .3 The prevailing wage rates are established by the State of Maryland and apply to all of the Contractor's employees and any and all Subcontractors and Sub-subcontractors.
- .4 The wage rates in effect, at the time the Owner issued the solicitation, are valid for the duration of the Contract.
- .5 The Contractor and all Subcontractors and Sub-subcontractors must pay employees the prescribed wage rates, as established by the State of Maryland Commissioner of Labor and Industry, in effect at the time the Owner issued the solicitation.
- .6 The Contractor and all Subcontractors and Sub-subcontractors must pay employees overtime for work more than 10 hours in any single day, work more than 40 hours in a work week, or work on Sunday or legal holiday;
- .7 The Contractor and all Subcontractors and Sub-subcontractors must classify employees in their proper work classification in conformance with the schedule established by the State of Maryland Commissioner of Labor and Industry;
- .8 The Contractor and all Subcontractors and Sub-subcontractors must electronically submit payroll records through [www.LCPTracker.net](http://www.LCPTracker.net), within 14 days after the end of each payroll period, to verify that Prevailing Wage rates have been paid to employees. The payroll records must include the following:

The name, address and telephone number of the Contractor or Subcontractor;  
The name and location of the job;  
Each employee's:

Name;  
Current address unless previously reported;  
Specific work classification;  
Daily straight time and overtime hours;  
Total straight time and overtime hours for the payroll period;  
Rate of pay;  
Fringe benefits by type and amount; and  
Gross wages.

- .9 If a Contractor and any of the Subcontractors and Sub-subcontractors are late in submitting copies of any payroll records required to be submitted under the Prevailing Wage Law, the Owner may deem invoices unacceptable until the Contractor, Subcontractors and Sub-subcontractors provide the required records, and may postpone processing payments due under the Contract or under an agreement to finance the Contract;
- .10 The Contractor, Subcontractors and Sub-subcontractors must retain all payroll records for a period not less than five (5) years after the Work is completed;
- .11 The Owner may inspect the payroll records at any reasonable time and as often as necessary;
- .12 The Owner and/or its agent may perform random or regular audits and investigate any complaint of a violation of the Prevailing Wage Law;
- .13 In the event the Owner determines that a provision of the Prevailing Wage Law has been violated, the Owner may withhold payment to the Contractor sufficient to pay each employee of the Contractor or any Subcontractors and Sub-subcontractors the full amount of wages due under the Prevailing Wage Law and an amount sufficient to satisfy a liability of a Contractor, Subcontractors, or Sub-subcontractors for liquidated damages as provided under the Prevailing Wage Law, pending a final decision on the violation by the Owner;

- .14 Contractor may appeal a written decision of the Director, Office of Procurement, that the Contractor violated a provision of the Prevailing Wage Law to the Chief Administrative Officer ("CAO") within ten (10) days after receiving a copy of the decision. The CAO must designate a hearing officer to conduct a hearing upon receipt of a timely appeal. If the Contractor does not appeal a written decision within ten (10) days after receipt, the decision of the Director, Office of Procurement, becomes final and binding;
- .15 Contractor and all Subcontractors and Sub-subcontractors must not discharge or otherwise retaliate against an employee for asserting any right under the Prevailing Wage Law or for filing a complaint of a violation;
- .16 Each Contract subject to the Prevailing Wage Law may specify the payment of liquidated damages to the County by the Contractor and any Subcontractors and Sub-subcontractors for any noncompliance with the Prevailing Wage Law. Liquidated damages for this Contract are: \$10 for each calendar day that the payroll records are late; \$20 per day for each day that an employee is misclassified; and \$50 per violation of the requirement to post the prevailing wage rates at the work site;
- .17 The failure of the Contractor and any of the Subcontractors and Sub-subcontractors to comply with the Prevailing Wage Law constitutes a material default under the Contract;
- .18 "An aggrieved employee" is a third-party beneficiary of this Contract and the employee may by civil action recover the difference between the prevailing wage for the type of work performed and the amount actually received, with interest and a reasonable attorney's fee; and
- .19 Where the initial Contract Sum is below the \$500,000.00 threshold, but it is subsequently increased and exceeds the \$500,000.00 threshold due to an approved Contract Modification, the amount of any such Contract Modification that causes the

Contract Sum to exceed the \$500,000.00 threshold is subject to the Prevailing Wage Law.

- .20 The Contractor, Subcontractors and Sub-subcontractors must post a clearly legible statement of each prevailing wage rate in a prominent and easily accessible place at the Work Site during the entire time Work is being performed, in English and any other language that is primarily spoken by the employees, at the Work Site.

**19.4.3 Bond.** If required to comply with Md. Code Ann., State Fin. & Proc., § 17-213(b), the Contractor must provide a suitable bond or guarantee, in a form approved by Owner, to insure the proper payment of the prevailing wage as required thereunder.

**19.5 COST AND PRICING DATA**

Chapter 11B of the Montgomery County Code and the Montgomery County Procurement Regulations require that cost and pricing data be obtained from contractors in certain situations. The Contractor guarantees that any cost and pricing data provided to the Owner will be accurate and complete. The Contractor grants the Director access to all books, records, documents, and other supporting data in order to permit adequate evaluation of the Contractor's proposed price(s). The Contractor also agrees that, in addition to all other remedies, the price to the Owner, including profit or fee, may, at the option of the Owner, be reduced to the extent that the price was based on inaccurate, incomplete, or noncurrent data supplied by the Contractor.

**19.6 HAZARDOUS AND TOXIC SUBSTANCES**

Manufacturers and distributors are required by federal "Hazard Communication" provisions (29 CFR §1910.1200), and the Maryland "Access to Information About Hazardous and Toxic Substances" Law, to label each hazardous material or chemical container, and to provide Material Safety Data Sheets to the purchaser. The Contractor must comply with these laws and must provide the Owner with copies of all relevant documents, including Material Safety Data Sheets, prior to performance of services or contemporaneous with delivery of goods.

**19.7 HEALTH INSURANCE PORTABILITY AND**

## **ACCOUNTABILITY ACT (HIPAA) COMPLIANCE**

Contractor must comply with all requirements in the federal Health Insurance Portability and Accountability Act (HIPAA), to the extent that HIPAA is applicable to this Contract. Furthermore, Contractor must enter into the Owner's standard Business Associate Agreement when Contractor or the Owner, as part of this Contract, may use or disclose to one another, to the individual whose health information is at issue, or to a third-party, any protected health information that is obtained from, provided to, made available to, or created by, or for, the Contractor or the Owner.

### **19.8 IMMIGRATION REFORM AND CONTROL ACT**

The Contractor warrants that both the Contractor and its Subcontractors do not, and shall not, hire, recruit or refer for a fee, for employment under this Contract or any Subcontract, an alien while knowing the alien is an unauthorized alien, or any individual without complying with the requirements of the federal Immigration and Nationality laws, including any verification and record keeping requirements. The Contractor further assures the Owner that, in accordance with those laws, it does not, and will not, discriminate against an individual with respect to hiring, recruitment, or referral for a fee, of an individual for employment or the discharge of an individual from employment, because of the individual's national origin or, in the case of a citizen or prospective citizen, because of the individual's citizenship status.

## **ARTICLE 20**

### **MISCELLANEOUS PROVISIONS**

#### **20.1 MISCELLANEOUS PROVISIONS.**

**20.1.1 Assignment.** The Contractor may not assign any part of the Contract without written consent of the Owner which consent is within the Owner's sole discretion.

**20.1.2 Assignment of Payments.** In the event the Contractor desires to make an assignment of any monies due or to become due under the Contract, the Contractor must file a copy of consent of Surety and a fully executed copy of the assignment with the Owner and the Architect/Engineer. Any such assignment must be approved by the Director.

**20.1.3 Audit Provisions.** The Owner has the right to examine the Contractor's, its

Subcontractors', Sub-subcontractors' and Suppliers' records directly or indirectly pertaining or relating to the Work or the Contract. The Owner must be granted access to and an opportunity to copy such records at all reasonable times during the Contract period and for three (3) years thereafter.

**20.1.4 Extent of Contract.** The Contract represents the entire and integrated agreement between the parties hereto and supersedes prior negotiations, representations or agreements, either written or oral.

**20.1.5 Governing Law.** The Contract is governed by the laws of the State of Maryland and of Montgomery, Maryland.

**20.1.6 Obligations Surviving Termination.** The Contractor's obligations under the correction of Work provisions of the Contract, Warranties, representations, indemnification obligations and other continuing obligations survive acceptance of the Work under the Contract and termination of the Contract; and do not relieve the Contractor of the Contractor's obligations thereunder.

**20.1.7 Severability of Provisions.** If any one or more of the provisions contained in the Contract Documents should be deemed invalid, illegal or unenforceable in any respect, the validity, legality, and enforceability of the remaining provisions contained herein are not to be affected or impaired thereby; provided the same does not materially alter the rights or obligations of the parties.

**20.1.8 Third Parties.** The Contract Documents are not to be construed to create a contractual relationship of any kind other than between the Owner and Contractor except as specified in Subsection 3.1.2.

**20.1.9 Venue and Jurisdiction.** The Contractor hereby waives venue and jurisdiction and submits to the venue and jurisdiction of the Circuit Court for Montgomery County, Maryland, relating to administrative appeals. **Any suit or action involving this Contract may only be brought in the Circuit Court for Montgomery County Maryland and only under the Maryland Rules governing administrative appeals, which along with Article 16 is the Contractor's sole and exclusive remedy for any and all Disputes arising under or relating in any way to the Contract, the Work or the Project.**

**20.1.10 Waiver of Breach.** Any action or failure to act by the Owner, Architect/Engineer or



Contractor does not constitute a waiver of any of their rights or obligations under the Contract. No such action or failure to act, whether or not repeated, constitutes a continuing waiver of any requirements of the Contract or any approval of or acquiescence in any breach.

**20.1.11 Written Notice.** Written notices are to be given to the representatives of the parties designated in the Contract. Written notice are deemed to have been duly served if delivered in person to the addressee for which it was intended, or if delivered or sent by mail to the last business address known to the party giving notice, provided that if sent by mail it must be by first class mail postage prepaid except, if to the Owner in which case it must be by registered or certified mail. Any notice given by facsimile or e-mail must be confirmed by a copy delivered personally or by mail, and in the case of the Owner, by registered or certified mail. The date of any notice is deemed to be the earlier of the date of personal delivery or receipt by facsimile or e-mail or similar means, or if mailed, the earlier of actual receipt or three (3) days after the postmark date.

**20.1.12 Intellectual Property Approval And Indemnification – Infringement.**

If the Contractor will be preparing, displaying, publicly performing, reproducing, or otherwise using, in any manner or form, any information, document, or material that is subject to a copyright, trademark, patent, or other property or privacy right, then the Contractor must:

.1 At its expense obtain all necessary licenses, authorizations, and approvals related to its use;

.2 Include the Owner in any approval, authorization, or license related to its use at no cost to the Owner; and

.3 Indemnify and hold harmless the Owner from and against all liabilities, actions, damages, claims, demands, judgments, losses, costs, expenses, suits, or actions, and attorneys' fees and the costs of the defense of the Owner, in any suit, including appeals, based upon or arising out of any allegation of infringement, violation, unauthorized use, or conversion of any patent, copyright, trademark or trade name, license, proprietary right, or other related property or privacy interest.

**END GENERAL CONDITIONS OF  
CONSTRUCTION CONTRACT.**





SECTION 01 1100 - SUMMARY OF WORK

PART 1 - GENERAL

1.1 RELATED DOCUMENTS

- A. Drawings and general provisions of the Contract, including General and Supplemental Conditions and other Division 1 Specification Sections, apply to this Section.

1.2 WORK COVERED BY CONTRACT DOCUMENTS

- A. Project Identification: Project consists of a full renovation of the existing hydraulic elevator and associated MEP Work.
  - 1. Project Location: Strathmore Mansion  
10701 Rockville Pike  
Rockville, MD 20850
  - 2. Owner: Montgomery County, Maryland.
- B. Design Team Identification:
  - 1. Elevator Consultant: Robert L. Seymour & Associates, Inc., 182 Thomas Johnson Drive Ste 200, Frederick, MD 21702; (301) 662-8112.
- C. The Work includes, but is not limited to, the following:
  - 1. ARCHITECTURAL:
    - a. Fire safing, sealants, finish paint.
    - b. Patch and paint any damaged wall surfaces in elevator lobbies.
    - c. Provide pit ladder.
    - d. Provide bar grating for secondary pit level.
  - 2. ELECTRICAL
    - a. Perform selective demolition of existing electrical conduits, wiring and equipment.
    - b. Provide new lighting and receptacles in elevator pits.
    - c. Replace existing disconnect switches for elevators replacement and provide new switch for new elevator, provide new feeders from the distribution panels.
    - d. Disconnect existing elevator electrical motors. Reconnect new motors.
    - e. Remove all existing controllers and provide new solid state controllers. Provide power to new controllers.
    - f. Provide new transformer and 120/208V panel to feed new elevator cabs power and lighting and new HVAC systems.
    - g. Provide new lighting and receptacles in elevator machine room.
    - h. Connect new HVAC unit located in the elevator machine room and associated outdoor unit.
    - i. Modify existing fire alarm to provide code compliant system for initiation of Firefighters' Emergency Operation.

3. MECHANICAL
  - a. Furnish and install new split system heat pump.
4. ELEVATORS
  - a. Replace pump unit and piping
  - b. Replace control
  - c. Replace buffers
  - d. Replace corridor control stations & signals
  - e. Replace car enclosure
  - f. Replace door operator & protection system
  - g. Replace car control station & signals
  - h. Replace jack assemblies
  - i. Replace car frame & platform
  - j. Refinish hoistway entrance frames
  - l. Replace hoistway door panels and hardware
5. FIRE PROTECTION
  - a. Provide sprinkler in elevator pit.

- D. The Project has been designated as one requiring "Special Inspections" by the Montgomery County Department of Permitting Services. The Contractor is required to abide by all requirements of the Special Inspections program including but not limited to: Reading and signing the Statement of Special Inspections in order to get the Building Permit, performance of its responsibilities concerning special inspections, testing and certifications per the Statement, and preparation and submittal of required documentation in order to obtain the Use and Occupancy Permit.
- E. The project shall comply with Complex Structures Requirements'. The Contractor is required to abide by all requirements including, but not limited to: Reading and signing the Agreement in order to get the Building Permit, performance of its responsibilities concerning special inspections, testing and certifications per the Statement, and preparation and submittal of required documentation in order to obtain the Use and Occupancy Permit.
- F. The Contract Documents showing the existing construction of the facility were developed from historic documents and from limited field observations by the Consultant. Actual conditions may vary from those shown. Hidden conditions may be discovered over the course of the work. Further investigations may uncover conditions which may require remedial attention prior to proceeding with demolition or construction. Contractor shall be aware of the need to proceed with diligence and care and shall notify Engineer of conditions which do not reflect those indicated or which require further testing and repair prior to proceeding. Contractor shall correct conditions that are detrimental to timely and proper execution of the Work. Contractor shall not proceed until unsatisfactory conditions have been corrected. Commencement or continuation of work constitutes acceptance of conditions and responsibility for satisfactory performance.

### 1.3 CONTRACT

- A. Work will be performed under a general construction contract.

1.4 CONTRACTOR SECURITY PROTOCOL

- A. The following security protocols are to be observed at existing Building at all times upon substantial completion :
1. Contractor's Designated Escort: Designate foreman/supervisor personnel to function as the Contractor's Designated Escort. Designated Escort must be on the work site in the designated work area at all times when workers are present on site. Work will not be allowed to commence until he/she is present at the work site. Designated Escort must submit to and receive background clearance from Security Office at least three weeks prior to start of Work. Assign two back-up Designated Escorts to be permitted as substitutes only if the primary Designated Escort is unable to be on site due to absence. Back-up Designated Escorts must also submit to and receive background clearance from the Security Office at least three weeks prior to start of Work. Designated Escort must check in at Security Office every workday. Designated Escort is responsible for security and confidentiality of the Work Areas.
  2. The Designated Escort will be the only member of the Contractor's team with access to keys within the building. The key will be checked out from the building manager's office on a daily basis. The Contractor must create a key check out form the includes the following: Name, Date, Company, Rooms where work will occur on that date, time room is opened, time room is locked, cell phone # and a certification that all rooms have been secured at the end of the work day. A copy of this form must be submitted and approved by the Security Office prior to beginning work. The form must be submitted every day the keys are checked out. The form must be logged throughout the day and signed by the Designated Escort when the keys are returned at the end of the workday. If the Contractor/Designated Escort fails to keep the proper logs or there are security issues or problems, key privileges will be revoked.
  3. Employee Check-In: Each Contractor employee to be present on the work site must be checked in with Security Office each workday with government-issued identification to receive contractor security badge. The photo identification will be retained by the Security Office until the contractor security badge is returned. Submit name and date of birth of each employee to be working on the work site at least three weeks prior to start of Work. All contractor personnel working on a particular day must check in at the same time that day as the Designated Escort.
- B. Pre-Construction Meeting: Approved primary and back-up Designated Escorts must attend pre- construction meeting at the Security Office to review security protocol and protections. Security Office will determine meeting time and location.
- C. Employee Screening: Comply with Owner's requirements regarding drug and background screening of Contractor personnel working on the Project site.
1. Background screening to be performed for all Contractor personnel as required by Security Office. Provide a list of employees 2 weeks prior to the commencement of Work.
  2. Maintain list of approved screened personnel with Owner's Representative.

1.5 USE OF PREMISES

- A. Use of Site: Limit use of premises to work in areas indicated on the Contract Documents and as permitted by law, ordinances and permits. Do not disturb portions of site beyond areas in which the Work is indicated.
1. Limits: Confine construction operations to designated areas indicated on Drawings.
  2. Owner Occupancy: Allow for Owner occupancy of the existing building and use by the public.
  3. Access: At all times, provide Architect/Engineer and Owner easy and safe access to the Work.
  4. Driveways and Entrances: Keep driveways and entrances serving the premises clear and available to Owner, Owner's employees, and emergency vehicles at all times. Do not use these areas for parking or storage of materials.
  5. Construction Parking: Contractor permitted to park in any legal location.
- B. Site Access and Staging Area: Contractor may access site from public streets and may only use areas for temporary staging construction activities, as approved by the Owner. The Contractor will be required to coordinate its activities with the Owner. If needed, Contractor shall obtain and pay for additional storage or work areas needed for operations.
- C. Interior Crane Use and Storage: If required, the Contractor will be allowed space to house the crane operations as designed by the Owner.
- D. Contractor shall provide barriers, protections, warning lines, signs, lighting and personnel to segregate work areas from pedestrian or vehicular traffic and to prevent damage to the building, adjacent buildings, paved areas and surrounding landscaping. Contractor shall repair any damage incurred to existing facility elements resulting from construction activities as soon as possible after occurrence of damage. Contractor shall observe all applicable O.S.H.A., M.O.S.H. and Montgomery County Government (MCG) requirements, as well as, requirements for any additional Authorities Having Jurisdiction.
1. Standard Working Hours: The standard permitted Working Hours shall be as indicated within the General Conditions for additional information.
    - a. Working Hours for Noise Restrictive Work: Perform all noisy and disruptive Work on weekends only. Weekend work hours are Saturday and Sunday from 9:00 am to 3:00 pm only.
    - b. The following requirements must be met for Work within the existing Building:
      - 1) The Building must be fully operation for each workday.
      - 2) Contractor shall cover and protect all equipment and furniture within work areas.
      - 3) Contractor shall secure and enclose the work area with floor-to-ceiling plywood partition in an effort to keep the public from entering unsecured elevator shafts and shall provide dust containment at each enclosure.
      - 4) Cleanup to be completed each day before the scheduled start of work for Building personnel.
      - 5) Working hours including Noise Restrictions: Limit work in the existing building from 7:00 am to 4:00 pm Monday through Friday, exclusive of County holidays. See Division 00 Section "General

Conditions” for additional information.

- 6) In addition to standard work hour restrictions, the Contractor shall comply with the Montgomery County Department of Environmental Protection’s permissible noise levels for construction activities during the hours of 7:00 am to 9:00 pm, Monday through Friday, and 9:00 am to 3:00 pm on Saturday. Noise generated by construction activities beyond these hours is strictly prohibited.
- 7) Montgomery County holidays are as follows: Contractor shall assume that County holidays for subsequent years shall be similar:
  - a) New Years Day
  - b) Martin Luther King, Jr. Day
  - c) President’s Day
  - d) Memorial Day
  - e) Independence Day
  - f) Labor Day
  - g) Columbus Day
  - h) Election Day
  - i) Veterans Day
  - j) Thanksgiving Day
  - k) Day After Thanksgiving
  - l) Christmas Day
  - m) New Years Eve
- 8) Working hours outside of those listed above are not permitted without prior approval by the County.
- 9) Work may occur during normal business hours provided it does not cause disruption to the operations of the Headquarters. Work is not permitted in any occupied space during normal business hours. Hours are 6:00 a.m. to 5:00 p.m., Monday, Tuesday, Wednesday and Friday, 6:00 am to 8:00 pm., Thursdays, excluding Holidays. These times vary daily. The building manager will notify the Contractor daily when events at the building may result in an unscheduled shutdown of construction operations. Determination of disruptive work will be at the sole discretion of the County and includes any noticeable odors or any audible noise in any occupied space.
- 10) Noise generated by construction activities during normal business hours is strictly prohibited. This includes, but is not limited to, hammering, drilling, use of power tools, vibrations, powder actuators, fasteners, etc.
- 11) Welding, hot work, and core drilling are prohibited during normal working hours. Contractor shall conform with all COR and NFPA requirements for welding inside occupied building.

E. Phasing: Refer to Section 01 1150 Construction Phasing Requirements and drawings for requirements.

F. Safety: Refer to Section 01 3523 for Contractor’s Safety Requirements.



- G. Utility Shutdowns: Obtain written approval from the Owner for any required shutdown or outage of any utility. Schedule any outages to minimize impact on existing operations. Comply with all applicable codes and ordinances.
  - H. Keep project site clean. Remove trash daily.
  - I. Nonsmoking site and building: Smoking is not permitted within the project site boundaries, within the existing building or within 25 feet of site/building entrances, existing operable windows, or existing outdoor air intakes.
  - J. Controlled Substances: Use of tobacco products and other controlled substances within the existing building and on the project site is not permitted.
- 1.6 PERMITS
- A. Refer to General Conditions for Owner-obtained and for Contractor-obtained permits.
- 1.7 TAXES
- A. Refer to General Conditions

PART 2 - PRODUCTS (Not Used)

PART 3 - EXECUTION (Not Used)

END OF SECTION 011100

SECTION 01 1150 - CONSTRUCTION PHASING REQUIREMENTS

PART 1 - GENERAL

- A. Perform associated work as defined on drawings. Building will remain occupied throughout construction.
- B. Vehicular access to building parking areas to be maintained at all times throughout construction.

1.2 CONSTRUCTION PHASES

- A. Required phasing will be one elevator at a time. Contractor to submit detailed phasing plan outlining means deemed most efficient by Contractor for completing Work. Deviations from the phasing described herein shall be submitted to the Owner and Engineer for approval.
- B. Contractor shall submit preliminary phasing plan during bidding process.

1.3 BASE BID PHASING ANALYSIS

- A. The following phasing (work sequence) is for the base bid.
- B. Work Sequence One: Refurbish passenger elevator in Car 1 location. Perform associated work as defined on drawings

1.4 SUBMITTALS

- A. Submit a Phasing Plan within 15 calendar days after the date established for the commencement of the Contract.
  - 1. Include all required work items, including installation, reconfiguration, and removal of temporary facilities.
  - 2. Identify all out-of-phase work items, and procedures for protecting building occupants and maintaining unimpeded pedestrian and vehicular access.

PART 2 - PRODUCTS (Not applicable)

PART 3 - EXECUTION (Not applicable)

END OF SECTION 011150

SECTION 01 2100 – ALLOWANCES

PART 1 - GENERAL

1.1 SUMMARY

- A. Section contains instructions that relate to an Allowance to be included in the Contract sum. Owner may elect certain aspects of work that cannot be determined at this time.

1.2 ALLOWANCE FOR PRODUCTS AND SERVICES

- A. The amount of the allowance includes:

1. The cost of the product or services to the Contractor, less any applicable trade discount.
2. Delivery of product to the site.
3. Labor required under the allowance to perform the work.
4. Applicable taxes.
5. Applicable Contractor mark-up.

- B. Allow the sum of \$25,000 to be carried in the Base Bid for unseen work discovered during demolition or otherwise identified by the Owner and performed by the Contractor during the course of the project.

- C. Contractor's duties:

1. Assist Owner in determining qualified suppliers or installers.
2. Obtain proposals from suppliers and installers when requested by Owner.
3. Make appropriate recommendations for consideration of Owner.
4. Applicable taxes.
5. Notify Owner promptly of:
  - a. Any reasonable objections Contractor may have against any supplier or party under consideration for installation.
  - b. Any effect on the construction schedule anticipated by selections under consideration.

1.3 CONTRACTOR RESPONSIBILITY FOR PURCHASE, DELIVERY, AND INSTALLATION

- A. On notification of selection, execute purchase agreement with designated supplier and perform the designated work.
- B. Arrange for and process shop drawings, product data, and samples, as required.
- C. Make all arrangements for delivery.

- D. Submit claims for transportation damage.
- E. Install, work, and finish products in compliance with requirements of Contract Documents.

1.4 ADJUSTMENT OF COSTS

- A. Upon determination of scope of repairs by Owner, submit cost proposal in accordance with Contract Conditions.
- B. Should the net cost be more than the specified amount of the allowance, the Contract Sum will be adjusted accordingly by the Change Order.
- C. Should the net cost be less than the specific amount of the allowance, the Contract Sum will be adjusted accordingly by the Change Order.
- D. Submit documentation for actual additional costs at the site or other expenses caused by the selection under the allowance, within 30 days after completion of execution of the work.
- E. Failure to submit claims within the designated time will constitute a waiver of claims for additional costs.
- F. At Contract closeout, reflect all approved authorizations of allowance funds in the final statement of accounting.

PART 2 - PRODUCTS (Not Used)

PART 3 - EXECUTION (Not Used)

END OF SECTION 012100

SECTION 01 3523 - CONTRACTOR'S SAFETY REQUIREMENTS

PART 1 - GENERAL

1.1 INTRODUCTION AND OBJECTIVES

- A. The Contractor must ensure the safety of all persons at and adjacent to the Project Site, the Work, and other property at or adjacent to the Site. The Contractor also must ensure that all persons working on the Project Site are aware of the Contractor's responsibility in ensuring safe working conditions.
- B. The Contractor is responsible for complying with all construction safety laws, regulations, codes and standards or any other laws governing safety matters including, but not limited to, Occupational Safety & Health Administration (OSHA), Maryland Occupational Safety and Health (MOSH), ANSI/ASSE, NFPA, NEC, AWS, and IEC regulations, and Manufacturer's Safety Instructions or Recommendations. The Contractor must take all prudent steps to ensure that the Contractor, and every Subcontractor or Sub-subcontractor, does not allow or require any worker employed in the performance of the Contract to work in surroundings or under working conditions which are unsanitary, hazardous, or dangerous to his/her health or safety.
- C. The Contractor must be familiar with all current safety and health laws, regulations, codes and standards or any other laws pertaining to the Work and must follow and enforce such legal requirements. The Contractor must take all prudent steps to ensure that every Subcontractor or Sub-subcontractor is familiar with all current safety and health laws, regulations, codes and standards or any other laws pertaining to its portion of the Work and follows and enforces such legal requirements. The Contractor must keep at the Site at all times, and have available, copies of all relevant construction safety and health laws, regulations, codes and standards.
- D. The Contractor must provide the safety training and direction required to handle the specific safety requirements particular to the Work. The Contractor must instruct its site personnel, and must ensure that every Subcontractor or Sub-subcontractor instructs its site personnel in the recognition and avoidance of unsafe conditions and the regulations applicable to his work environment to control or eliminate any hazards or other exposure to illness or injury.

1.2 SCOPE, RELATED DOCUMENTS, AND SAFETY LAWS

- A. The Contractor's safety requirements include those requirements set forth in this section, and in the Contract Documents, as well as those requirements imposed by OSHA, MOSH, and all other applicable safety laws, regulations, codes and standards (collectively referred to as the "Contractor's Safety Requirements").
- B. In the event of any conflict between this section and any safety laws, regulations, codes and standards including, but not limited to, OSHA and MOSH requirements, the stricter requirement shall apply. However, in all cases, the Contractor's full compliance

with all applicable safety laws, regulations, codes and standards including, but not limited to, ANSI, OSHA and MOSH requirements is required.

- C. The Contractor is responsible for initiating, maintaining, and supervising all safety precautions in connection with the performance of the Contract. Neither the Owner nor the Engineer have control over, or charge of, or are responsible for construction means, methods, techniques, sequences or procedures, or for safety precautions and programs in connection with the Work, since these are solely the Contractor's responsibility as provided in the Contract Documents.

### 1.3 SPECIFIC CONTRACTOR SAFETY RESPONSIBILITIES

- A. The Contractor must plan for the overall safety and health on the Project. As part of the planning process, the Contractor must develop a Project-specific Safety Plan to include Job Safety Analyses (JSAs) for all hazardous tasks. The Contractor must establish regular safety and health planning meetings with all Subcontractors and Sub-subcontractors for the purpose of coordinating Project activities. The Contractor must ensure that all persons at the Project Site are adequately trained and competent to carry out the work assigned to them. The Contractor must ensure that all persons at the Project Site are aware of any known hazards likely to occur in the course of the Work and to ensure that they are instructed in the safety procedures to be followed to avoid these hazards. All workers must receive a safety orientation (Reference ANSI/ASSE A10.1).
- B. General Safety and Health Provisions (CFR 29 OSHA 1926.20)
1. The Contractor must designate a Safety Supervisor (also known as a Safety Officer) with minimum 30 hours of OSHA construction outreach certified safety training. The Safety Supervisor must control and ensure safety on the project site, and maintain documentation of the safety program including all record keeping and reporting. The Safety Supervisor must also be trained on how to manage safety on the construction site including how to give a toolbox talk and how to respond to, investigate, and report an accident.
  2. The Project Site must be secured and protected. Only authorized personnel must be allowed on Site. The Contractor must ensure that the Site is kept clean and safe daily. All adjacent properties to the Project Site must be protected. All visitors to the Project Site must wear appropriate protective clothing including work boots, safety vests and hard hats.
  3. The Contractor must ensure that each employee of the Contractor or any Subcontractor or Sub-subcontractor at the Project Site is trained: in the recognition and avoidance of unsafe conditions, and regarding the regulations applicable to his/her work environment to control or eliminate any hazards or other exposure to illness or injury.
  4. The Contractor must post the name, telephone number, and address of the Safety Supervisor for the Site at prominent and visible locations.
  5. The Contractor must ensure that each employee of the Contractor or any



- Subcontractor or Sub-subcontractor at the Project Site is trained to immediately notify the Safety Supervisor in the event of an emergency or unsafe site condition. In case of a critical injury or a fatality, the Safety Supervisor must immediately call 911 and then notify MOSH, the Owner's On-site Representative, and County Project Manager within one hour of the incident.
6. The Contractor must provide adequate containers for the collection and separation of waste, trash, oily rags, used rags, and other refuse. Containers used for garbage and other oily, flammable, or hazardous wastes, such as caustics, acids, harmful dusts, etc. must be equipped with covers. Garbage and other waste must be disposed of at frequent and regular intervals.
  7. The Contractor must be responsible for the removal of all waste from the Project Site. Waste must be collected in suitable containers. The Contractor must notify the Owner of any unanticipated hazardous wastes encountered at the Project Site; all hazardous wastes must be appropriately disposed of by the Contractor in accordance with all governing regulations including but not limited to Maryland Department of Environment (MDE) and Montgomery County Department of Environmental Protection (DEP) regulations.
- C. Occupational Health and Environmental Controls (CFR 29 OSHA 1926.51)
1. The Contractor must ensure that plans are codified in the Project-specific Safety Plan, prior to commencement of the Project, for prompt medical attention in case of serious injury. If an infirmary, clinic, hospital, or physician is not reasonably accessible in terms of time and distance to the Site for the treatment of injured employees, the Contractor must ensure the Site presence of a person with a valid certificate in first-aid training from the American Red Cross, or equivalent training that can be verified by documentary evidence, to render first aid. First aid supplies must be easily accessible when required.
  2. The Contractor must ensure that protection against excessive noise exposure is provided when the Site sound levels (continuous, intermittent and impulse) exceed 85 dBA and above. Where possible, noise must be controlled at the source through the use of engineering and administrative controls to minimize the need for personal protective equipment (Reference: ANSI/ASSE A10.46 Appendix 1).
  3. The Contractor must ensure that site personnel are not exposed to inhalation, ingestion, skin absorption, or contact with any material or substance at a concentration above those specified in the current edition of "Threshold Limit Values of Airborne Contaminants" of the American Conference of Governmental Industrial Hygienists.
  4. The Contractor must ensure that construction areas, ramps, runways, corridors, offices, shops, and storage areas are lighted to not less than the minimum illumination intensities listed in Table D-3 of Part D, CFR 29 OSHA 1926 for Construction while any work is in progress.

5. The Contractor must ensure that, whenever hazardous substances such as dusts, fumes, mists, vapors, or gases exist or are produced in the course of the Work, their concentrations do not exceed the limits specified in the latest edition of ACGIH "Threshold Limit Values of Airborne Contaminants".
  6. For compliance with the airborne toxin limits as described above; the Contractor must implement administrative or engineering controls first whenever possible. (Part D, CFR 29 OSHA 1926.55(b)). If administrative or engineering controls cannot adequately reduce exposures, the Contractor must use respirators in compliance with a full respiratory protection program. The respiratory protection program administrator must be designated and is responsible for the implementation of the program. (29 CFR 1926.55(b) and .103 (referencing 1910.134)).
  7. When ventilation is used as an engineering control method, the Contractor must install and operate the system according to the requirements of CFR 29 OSHA 1926 for Construction, mechanical codes, and any other applicable law, regulation, code or standard.
  8. When local exhaust ventilation is used, the Contractor must design the ventilation to prevent dispersion into the air of dusts, fumes, mists, vapors, and gases in concentrations causing harmful exposure. Such exhaust systems must be so designed that dusts, fumes, mists, vapors, or gases are not drawn through the work area of persons at the Project Site.
- D. Personal Protective & Life Safety Equipment (CFR 29 OSHA 1926.95)
2. The Contractor must ensure that all persons at the Project Site wear appropriate clothing and personal protective equipment (PPE) for the type of work being performed. The Contractor must ensure all persons at the Project Site are trained in the appropriate wear, use and maintenance of their PPE. The Contractor must ensure that no alcoholic beverages, narcotics or other dangerous drugs are used or allowed on the Project Site and must ensure that no smoking is permitted in any building(s), including the building(s) under construction. The Contractor must post NO SMOKING signs at appropriate locations to enforce this requirement.
  3. The Contractor must provide, use, and maintain in a sanitary and reliable condition protective equipment, including personal protective equipment for eyes, face, head, and extremities, protective clothing, respiratory devices, and protective shields and barriers, wherever it is necessary by reason of hazards of processes or environment, chemical hazards, radiological hazards, or mechanical irritants encountered in a manner capable of causing injury or impairment in the function of any part of the body through absorption, inhalation or physical contact.
  4. Where employees provide their own protective equipment, the Contractor must ensure its adequacy including proper maintenance, and sanitation of such equipment.
- E. Fire Protection and Prevention (CFR 29 OSHA 1926.150)
1. The Contractor must develop a fire protection program to be followed throughout all phases of the Work. The Contractor must provide for firefighting equipment as required by any work hazard and, as any fire hazard occurs, there must be no delay in providing the necessary equipment. Access to all available firefighting equipment must be maintained at all times.
  2. The Contractor must install electrical wiring and equipment for light, heat, or power purposes in compliance with the requirements of the Contract.

3. Internal combustion engine powered equipment must be so located that the exhausts are well away from combustible materials. When the exhausts are piped to outside the building under construction, a clearance of at least 6 inches must be maintained between such piping and combustible material.
  4. The Contractor must ensure that appropriate fire prevention measures are taken while working at the Project Site. The Contractor must take all necessary precautions to prevent accidental activation of fire alarms. Combustible material must not be placed near heaters. Welding and cutting are only permitted within easy reach of a suitably rated and charged fire extinguisher. Care must be taken to prevent sparks from falling on combustible material, workers or others near the site. Smoking is prohibited in all buildings, including buildings under construction and portable site offices. The Contractor must ensure that matches and smoking materials are properly extinguished when smoking in designated areas.
  5. Smoking must be prohibited at or in the vicinity of operations which constitute a fire hazard, and must be conspicuously posted: "No Smoking or Open Flame."
- F. Signs, Signals and Barricades (CFR 29 OSHA 1926.200)
1. Signs and symbols required by applicable safety laws, regulations, codes and standards must be visible at all times when work is being performed, and must be removed or covered promptly when the hazards no longer exist.
  2. The Contractor must provide traffic control on the Site and its vicinity according to OSHA/MOSH requirements and the Contract Documents. All traffic control signs or devices used for protection of construction workers must conform to Part VI of the Manual of Uniform Traffic Control Devices (AMUTCD). For traffic control, Class 2 high visibility clothing must be worn on the Site, particularly for road work, Class 3 clothing must be worn at night. The Contractor must designate a safe parking location on or off the Site.
- G. Materials Handling and Storage, Use and Disposal (CFR 29 OSHA 1926.250)
1. All materials stored in tiers must be stacked, racked, blocked, interlocked, or otherwise secured to prevent sliding, falling or collapse. Maximum safe load limits of floors within buildings and structures, in pounds per square foot, must be conspicuously posted in all storage areas, except for floor or slab on grade. Maximum safe loads must not be exceeded. Aisles and passageways must be kept clear to provide for the free and safe movement of material handling equipment or employees. Such areas must be kept in good repair. Reference ANSI/ASSE A10.46
  2. All materials, whether temporary or permanent, must be suitable for its intended use and must be stored and installed in strict conformance with the manufacturer's instructions. Material Safety Data Sheets (MSDS) must be available on site.
  3. The Contractor must ensure that all equipment is in good working condition, properly maintained and certified if required by regulations. Only trained and certified personnel must be allowed to operate equipment.
- H. Tools – Hand and Power (CFR 29 OSHA 1926.300)
1. The Contractor must ensure that all hand and power tools and similar equipment, whether furnished by the employer or the employee, are maintained in a safe condition.
  2. When power operated tools are designed to accommodate guards, they must be

equipped with such guards when in use. Belts, gears, shafts, pulleys, sprockets, spindles, drums, fly wheels, chains, or other reciprocating, rotating or moving parts of equipment must be guarded if such parts are exposed to contact by employees or otherwise create a hazard. Guarding must meet the requirements as set forth in American National Standards Institute B15.1-1953 (R1958), Safety Code for Mechanical Power-Transmission Apparatus.

I. Welding and Cutting (CFR 29 OSHA 1926.352)

1. All welding, cutting activities, materials and equipment must conform to ANSI Z 49.1 Standard and MOSH and OSHA requirements.
2. The Contractor must ensure that their workers and employees use the required specialized personal protective equipment required when working with welding or cutting equipment. The Contractor must also ensure that welding curtains are used where possible to protect other persons and property near the Project Site from welding arcs and flash. Hot work permit(s) must be used and enforced.
3. When practical, objects to be welded, cut, or heated must be moved to a designated safe location or, if the objects to be welded, cut, or heated cannot be readily moved, all movable fire hazards in the vicinity must be taken to a safe place, or otherwise protected. If the object to be welded, cut, or heated cannot be moved and if all the fire hazards cannot be removed, positive means must be taken to confine the heat, sparks, and slag, and to protect the immovable fire hazards from them.
4. Suitable fire extinguishing equipment must be immediately available in the work area and must be maintained in a state of readiness for instant use.
5. All combustible or flammable materials within 50 feet of the site which can neither be hosed down with water nor moved away from the area must be protected by a covering of non-combustible material at all times during the operations.

J. Electrical (CFR 29 OSHA 1926.402)

1. All electrical activities, materials and equipment must conform to all safety requirements including but not limited to NEC, IEC, NFPA 101, MOSH and OSHA requirements.
  - a. NOTE: If the electrical installation is made in accordance with the National Electrical Code ANSI/NFPA 70, exclusive of Formal Interpretations and Tentative Interim Amendments, it will be deemed to be in compliance with OSHA 1926 – for the purposes of this Specification Section only.
2. Reference CFR 1926, Subparts V – Power Transmission and Distribution, CC – Cranes and Derrick in Construction, for requirement regarding possible contact with live circuits in equipment and overhead.

K. Scaffolds (CFR 29 OSHA 1926.451)

1. The Contractor must ensure that each scaffold and scaffold component is capable of supporting, without failure, its own weight and at least 4 times the maximum intended load to be applied or transmitted to it.
2. Direct connections to roofs and floors, and counterweights used to balance adjustable suspension scaffolds, must be capable of resisting at least 4 times the tipping moment imposed by the scaffold operating at the rated load of the hoist, or 1.5 (minimum) times the tipping moment imposed by the scaffold operating at the stall load of the hoist, whichever is greater.
3. Each suspension rope, including connecting hardware, used on non-adjustable suspension scaffolds must be capable of supporting, without failure, at least 6



- times the maximum intended load applied or transmitted to that rope.
4. Aerial lifts must be designed and constructed in conformance with the applicable requirements of the American National Standards for "Vehicle Mounted Elevating and Rotating Work Platforms," ANSI A92.2-current edition, including appendix. Aerial lifts include the following types of vehicle-mounted aerial devices used to elevate personnel to job-sites above ground: Extensible boom platforms; Aerial ladders; Articulating boom platforms; Vertical towers. Lift controls must be tested each day prior to use to determine that such controls are in safe working condition. Only authorized persons shall operate an aerial lift.
  5. The Contractor must ensure that each employee who performs work while on a scaffold is trained by a person qualified in the subject matter to recognize the hazards associated with the type of scaffold being used and to understand the procedures to control or minimize those hazards. The training must include the following areas, as applicable: the nature of any electrical hazards, fall hazards and falling object hazards in the work area; the correct procedures for dealing with electrical hazards and for erecting, maintaining, and disassembling the fall protection systems and falling object protection systems being used; the proper use of the scaffold, and the proper handling of materials on the scaffold; the maximum intended load and the load-carrying capacities of the scaffolds used; and any other pertinent requirements.
  6. The Contractor must ensure that each employee who is involved in erecting, disassembling, moving, operating, repairing, maintaining, or inspecting a scaffold is trained by a competent person to recognize any hazards associated with the work in question.
  7. When the Contractor has reason to believe that a person at the Project Site lacks the skill or understanding needed for safe work involving the erection, use or dismantling of scaffolds, the contractor must require the training or retraining of each such employee so that the requisite proficiency is demonstrated. This training or retraining is required in at least the following situations: where changes at the worksite present a hazard about which an employee has not been previously trained; or where changes in the types of scaffolds, fall protection, falling object protection, or other equipment present a hazard about which an employee has not been previously trained; or where inadequacies in an affected employee's work involving scaffolds indicate that the employee has not retained the requisite proficiency.
  8. Mast climber platforms must be erected, used, and dismantled according to the manufacturer's specification. Special care must be taken to ensure there is no corrosion of scaffold components. The Contractor must ensure that loading and balancing limitations are observed; that bases are adequately supported, and that anchorages are sufficient. The travel path must be free of obstructions. Full guardrail systems and adequate planking are maintained, and tie-offs during dismantling the platform are not removed prematurely.
  9. All scaffolding systems including mast climber platforms must require a safety inspection and must be clearly tagged cleared for use by third party before they can be put into service.

L. Fall Protection (CFR 29 OSHA 1926.501)

1. The Contractor must determine if the walking/working surfaces on which any persons at the Site are to travel have the strength and structural integrity to support the persons safely. Any persons at the Site must be allowed on those

2. surfaces only when the surfaces have the requisite strength and structural integrity. Each person at the Site on a walking/working surface (horizontal and vertical surface) with an unprotected side or edge which is 6 feet (1.8 m) or more above a lower level must be protected from falling by the use of guardrail systems, safety net systems, or personal fall arrest systems.
  3. Guardrail systems and their use must comply with the following provisions: Top edge height of top rails, or equivalent guardrail system members, must be 42 inches plus or minus 3 inches above the walking/working level. When conditions warrant, the height of the top edge may exceed the 45-inch height, provided the guardrail system meets all other criteria of this paragraph. Note: When employees are using stilts, the top edge height of the top rail, or equivalent member, must be increased an amount equal to the height of the stilts.
  4. Midrails, screens, mesh, intermediate vertical members, or equivalent intermediate structural members must be installed between the top edge of the guardrail system and the walking/working surface when there is no wall or parapet wall at least 21 inches high. Midrails, when used, must be installed at a height midway between the top edge of the guardrail system and the walking/working level. Screens and mesh, when used, must extend from the top rail to the walking/working level and along the entire opening between top rail supports.
  5. Guardrail systems must be capable of withstanding, without failure, a force of at least 200 pounds applied within 2 inches of the top edge, in any outward or downward direction, at any point along the top edge. When the 200 pound test load is applied in a downward direction, the top edge of the guardrail must not deflect to a height less than 39 inches above the walking/working level.
  6. Midrails, screens, mesh, intermediate vertical members, solid panels, and equivalent structural members must be capable of withstanding, without failure, a force of at least 150 pounds applied in any downward or outward direction at any point along the midrail or other member. Guardrail systems must be so surfaced as to prevent injury to an employee from punctures or lacerations, and to prevent snagging of clothing. The ends of all top rails and midrails must not overhang the terminal posts, except where such overhang does not constitute a projection hazard.
  7. The Contractor must ensure provide a training program for each employee who might be exposed to fall hazards. The program must enable each employee to recognize the hazards of falling and must train each employee in the procedures to be followed in order to minimize these hazards.
  8. Where possible, site personnel must be protected from falls through use of guardrail systems. Personal fall arrest systems must be used only where guardrail systems are technically not possible. The use of personal fall arrest systems must comply with 29 CFR 1926.502(d).
- M. Excavations (CFR 29 OSHA 1926.651)
1. All surface encumbrances that are located so as to create a hazard to site personnel must be removed or supported, as necessary, to safeguard employees.
  2. The estimated location of utility installations, such as sewer, telephone, fuel, electric, water lines, or any other underground installations that reasonably may be expected to be encountered during excavation work, must be determined prior to opening an excavation. When excavation operations approach the estimated location of underground installations, the exact location of the installations must be determined by safe and acceptable means. While the excavation is open, underground installations must be protected, supported or removed as necessary to safeguard employees.



3. A stairway, ladder, ramp or other safe means of egress must be located in trench excavations that are 4 feet or more in depth so as to require no more than 25 feet of lateral travel for employees.
4. Persons on the Site exposed to public vehicular traffic must be provided with, and must wear; warning vests or other suitable garments marked with or made of reflectorized or high-visibility material.
5. No person on the Site shall be permitted underneath loads handled by lifting or digging equipment. Persons must be required to stand away from any vehicle being loaded or unloaded to avoid being struck by any spillage or falling materials. Operators may remain in the cabs of vehicles being loaded or unloaded when the vehicles are equipped, to provide adequate protection for the operator during loading and unloading operations.
6. When mobile equipment is operated adjacent to an excavation, or when such equipment is required to approach the edge of an excavation, and the operator does not have a clear and direct view of the edge of the excavation, a warning system must be utilized such as barricades, hand or mechanical signals, or stop logs. If possible, the grade should be away from the excavation.
7. The Contractor must perform testing and controls to prevent exposure to harmful levels of atmospheric contaminants and to assure acceptable atmospheric conditions in accordance with the following requirements: Where oxygen deficiency (atmospheres containing less than 19.5 percent oxygen) or a hazardous atmosphere exists or could reasonably be expected to exist, such as in excavations in landfill areas or excavations in areas where hazardous substances are stored nearby, the atmospheres in the excavation must be tested before employees enter excavations greater than 4 feet in depth. Adequate precautions must be taken to prevent employee exposure to atmospheres containing less than 19.5 percent oxygen and other hazardous atmospheres. These precautions include providing proper respiratory protection or ventilation.
8. Each person in an excavation or trench must be protected from cave-ins by an adequate protective system designed with the capacity to resist without failure all loads that are intended or could reasonably be expected to be applied or transmitted to the system.
9. The slopes and configurations of sloping and benching systems must be selected and constructed by the Contractor and supervised by a competent person.

N. Concrete and Masonry Construction (CFR 29 OSHA 1926.701)

1. No construction loads must be placed on a concrete structure or portion of a concrete structure unless the Contractor determines, based on information received from a person who is qualified in structural design, that the structure or portion of the structure is capable of supporting the loads.
2. All protruding reinforcing steel, onto and into which Site persons could fall, must be guarded to eliminate the hazard of impalement.
3. No persons on the Site (except those essential to the post-tensioning operations) shall be permitted to be behind the jack during tensioning operations. Signs and barriers must be erected to limit personnel access to the post-tensioning area during tensioning operations.
4. No person shall be permitted to ride concrete buckets. No person shall be permitted to work under concrete buckets while buckets are being elevated or lowered into position. To the extent practical, elevated concrete buckets must be routed so that no person, or the fewest number of persons, is exposed to the hazards associated with falling concrete buckets. No person shall be permitted to

apply a cement, sand, and water mixture through a pneumatic hose unless the person is wearing protective head and face equipment.

5. A limited access zone must be established whenever a masonry wall is being constructed. The limited access zone must be established prior to the start of construction of the wall. The limited access zone must be equal to the height of the wall to be constructed plus four feet, and must run the entire length of the wall. The limited access zone must be established on the side of the wall which will be unscaffolded. The limited access zone must be restricted to entry by persons actively engaged in constructing the wall. No other persons shall be permitted to enter the zone.

O. Steel Erection (CFR 29 OSHA 1926.752)

1. Before authorizing the commencement of steel erection, the Contractor must ensure that the steel erector is provided with the following written notifications: The concrete in the footings, piers and walls and the mortar in the masonry piers and walls has attained, on the basis of an appropriate ASTM standard test method of field-cured samples, either 75 percent of the intended minimum compressive design strength or sufficient strength to support the loads imposed during steel erection. Any repairs, replacements and modifications to the anchor bolts were conducted.
2. The Contractor must ensure that the following is provided and maintained: Adequate access roads into and through the site for the safe delivery and movement of derricks, cranes, trucks, other necessary equipment, and the material to be erected and means and methods for pedestrian and vehicular control. Exception: This requirement does not apply to roads outside of the construction site. A firm, properly graded, drained area, readily accessible to the work with adequate space for the safe storage of materials and the safe operation of the erector's equipment.
3. All hoisting operations in steel erection must be pre-planned per a Site-specific erection plan. Where the Contractor elects, due to conditions specific to the site, to develop alternate means and methods that provide personnel protection, it must be detailed in a site-specific erection plan developed by a qualified person and available at the work site.
4. Where technically possible, the Contractor must protect personnel from falls during leading edge work through the use of engineered systems designed to provide ample anchorage points along the leading edge of the work.

P. Demolition (CFR 29 OSHA 1926.850)

1. Prior to permitting personnel to start demolition operations, a written engineering survey must be made, by a competent person, of the structure to determine the condition of the framing, floors, and walls, and possibility of unplanned collapse of any portion of the structure. Any adjacent structure where personnel may be exposed must also be similarly checked. Also, a survey for hazardous materials including but not limited to asbestos shall be conducted; all potential hazardous materials shall be identified and removed prior to commencing demolition work. The Contractor must have written evidence that such surveys have been performed. All electric, gas, water, steam, sewer, and other service lines must be shut off, capped, or otherwise controlled, outside the building line before demolition work is started. In each case, any utility company which is involved

- must be notified in advance.
2. When debris is dropped through holes in the floor without the use of chutes, the area onto which the material is dropped must be completely enclosed with barricades not less than 42 inches high and not less than 6 feet back from the projected edge of the opening above. Signs, warning of the hazard of falling materials, must be posted at each level. Removal must not be permitted in this lower area until debris handling ceases above. All floor openings, not used as material drops, must be covered over with material substantial enough to support the weight of any load which may be imposed. Such material must be properly secured to prevent its accidental movement. Except for the cutting of holes in floors for chutes, holes through which to drop materials, preparation of storage space, and similar necessary preparatory work, the demolition of exterior walls and floor construction must begin at the top of the structure and proceed downward. Each story of exterior wall and floor construction must be removed and dropped into the storage space before commencing the removal of exterior walls and floors in the story next below.
  3. Personnel entrances to multistory structures being demolished must be completely protected by sidewalk sheds or canopies, or both, providing protection from the face of the building for a minimum of 8 feet. All such canopies must be at least 2 feet wider than the building entrances or openings (1 foot wider on each side thereof), and must be capable of sustaining a load of 150 pounds per square foot.
  4. To the extent possible, mechanical demolition must be conducted using wet methods to control personnel's and the public's exposure to dust.
- Q. Blasting and Use of Explosives (CFR 29 OSHA 1926.900)
1. The Contractor must permit only authorized and qualified persons to handle and use explosives. Smoking, firearms, matches, open flame lamps, and other fires, flame or heat producing devices and sparks must be prohibited in or near explosive magazines or while explosives are being handled, transported or used. No person shall be allowed to handle or use explosives while under the influence of intoxicating liquors, narcotics, or other dangerous drugs.
  2. All explosives must be accounted for at all times. Explosives not being used must be kept in a locked magazine, unavailable to persons not authorized to handle them. The contractor must maintain an inventory and use record of all explosives. Appropriate authorities must be notified of any loss, theft, or unauthorized entry into a magazine. No explosives or blasting agents shall be abandoned.
  3. No fire shall be fought where the fire is in imminent danger of contact with explosives. All employees must be removed to a safe area and the fire area guarded against intruders.
- R. Ladders (CFR 29 OSHA 1926.1051)
1. A stairway or ladder must be provided at all personnel points of access where there is a break in elevation of 19 inches or more, and no ramp, runway, sloped embankment, or personnel hoist is provided. Employees must not use any spiral stairways that will not be a permanent part of the structure on which construction work is being performed. A double-cleated ladder or two or more separate ladders must be provided when ladders are the only mean of access or exit from a working area for 25 or more persons, or when a ladder is to serve simultaneous two-way



- traffic.
2. When a building or structure has only one point of access between levels, that point of access must be kept clear to permit free passage of personnel. When work must be performed or equipment must be used such that free passage at that point of access is restricted, a second point of access must be provided and used. The Contractor must provide and install all stairway and ladder fall protection systems required before personnel begin any work that necessitates the installation and use of stairways, ladders, and their respective fall protection systems.
  3. The Contractor must provide a training program for each employee who might be exposed to hazards of working on ladders. The program must enable each employee to recognize the hazards - and must train each employee in the procedures to be followed in order to minimize these hazards.
- S. Power Transmission and Distribution (CFR 29 OSHA 1926.950)
1. Existing conditions must be determined before starting work, by an inspection or a test. Such conditions shall include, but not be limited to, energized lines and equipment, conditions of poles, and the location of circuits and equipment, including power and communication lines, CATV and fire alarm circuits.
  2. Electric equipment and lines must be considered energized until determined to be de-energized by tests or other appropriate methods or means. Operating voltage of equipment and lines must be determined before working on or near energized parts. No personnel shall be permitted to approach or take any conductive object without an approved insulating handle closer to exposed energized parts than shown in OSHA 1926.950 Table V-1, unless: The person is insulated or guarded from the energized part (gloves or gloves with sleeves rated for the voltage involved shall be considered insulation of the employee from the energized part), or the energized part is insulated or guarded from him and any other conductive object at a different potential, or the person is isolated, insulated, or guarded from any other conductive object(s), as during live-line bare-hand work.
  3. The minimum working distance and minimum clear hot stick distances stated in OSHA 1926.950 Table V-1 must not be violated. The minimum clear hot stick distance is that for the use of live-line tools held by linemen when performing live-line work. Conductor support tools, such as link sticks, strain carriers, and insulator cradles, may be used:  
Provided, that the clear insulation is at least as long as the insulator string or the minimum distance specified in OSHA 1926.950 Table V-1 for the operating voltage.
- T. Cranes and Derricks (CFR 1926 Subparts V – Power Transmission and Distribution, CC – Cranes and Derrick in Construction)
1. "Ground conditions" means the ability of the ground to support the equipment (including slope, compaction, and firmness). "Supporting materials" means blocking, mats, cribbing, marsh buggies (in marshes/wetlands), or similar supporting materials or devices.
  2. The equipment must not be assembled or used unless ground conditions are firm, drained, and graded to a sufficient extent so that, in conjunction (if necessary) with the use of supporting materials, the equipment manufacturer's specifications for adequate support and degree of level of the equipment are met. The requirement for the ground to be drained does not apply to marshes/wetlands.
  3. The Contractor must: Ensure that ground preparations necessary to meet the

- requirements have been completed and tested. Inform the user of the equipment and the operator of the location of hazards beneath the equipment set-up area (such as voids, tanks, utilities) if those hazards are identified in documents (such as site drawings, as-built drawings, and soil analyses) that are in the possession of the Contractor (whether at the site or off-site) or the hazards are otherwise known to the Contractor.
4. If the A/D director for the crane and derrick Subcontractor (or Sub-subcontractor) determines that ground conditions do not meet the requirements for safe operation of the crane/derrick, that Subcontractor (or Sub-subcontractor) must have a discussion with the Contractor regarding the ground preparations that are needed so that, with the use of suitable supporting materials/devices (if necessary), safe operation requirements can be met.
  5. Assembly/disassembly must be directed by a person who meets the criteria for both a competent person and a qualified person, or by a competent person who is assisted by one or more qualified persons ("A/D director"). The A/D director must understand the applicable assembly/disassembly procedures. The A/D director must review the applicable assembly/disassembly procedures immediately prior to the commencement of assembly/disassembly unless the A/D director understands the procedures and has applied them to the same type and configuration of equipment (including accessories, if any).
  6. Before commencing assembly/disassembly operations, the A/D director must ensure that the crew members understand all of the following: Their tasks, the hazards associated with their tasks, and the hazardous positions/locations that they need to avoid.
  7. Before a crew member goes to a location that is out of view of the operator and is either in, on, or under the equipment, or near the equipment (or load) where the crew member could be injured by movement of the equipment (or load), the crew member must inform the operator that he/she is going to that location. Where the operator knows that a crew member went to a location, the operator must not move any part of the equipment (or load) until the operator is informed in accordance with a pre-arranged system of communication that the crew member is in a safe position.
  8. The Contractor must coordinate with a power line owner/operator prior to use of a crane/derrick near a power line. The power line owner/operator's registered professional engineer, who is a qualified person with respect to electrical power transmission and distribution, shall determine the minimum clearance distance that must be maintained to prevent electrical contact in light of the on-site conditions. The factors that must be considered in making this determination include, but are not limited to: Conditions affecting atmospheric conductivity; time necessary to bring the equipment, load line, and load (including rigging and lifting accessories) to a complete stop; wind conditions; degree of sway in the power line; lighting conditions, and other conditions affecting the ability to prevent electrical contact.

#### 1.4 CONTRACTOR SAFETY RESPONSIBILITIES FOR EMERGENCIES

- A. The Contractor must display a list of "Emergency Telephone Numbers" at visible locations of project site including, as a minimum, outside of the Contractor's trailer or office; a minimum list of Emergency Telephone Numbers is shown at the end of this section. In the event of an emergency or unsafe site condition, site personnel must be instructed to immediately notify the Safety Supervisor. In case of a critical injury or a

fatality, site personnel must be instructed to immediately call 911 and to immediately notify the safety supervisor. The safety supervisor must immediately call 911 (if others have not already done so) and then notify MOSH, the Owner's On-Site Representative, and the County Project Manager within one hour of the incident.

- B. The Contractor must train site personnel to know how to evacuate the Project Site in the event of an emergency. The Contractor must train site personnel to be aware of all the possible obstructions to entry and exit routes, to know an escape path, and to note the location of fire extinguishers before starting work.
- C. Contractors must keep a current list of names of all site personnel including all employees of the Contractor, the Subcontractors and Sub-subcontractors at all time to be able to account for everyone in the event of an emergency.

#### EMERGENCY TELEPHONE NUMBERS

911 General Emergencies (Ambulance, Fire and Police)

SAFETY SUPERVISOR (office and cell phone number)

MOSH PROJECT MANAGER

OWNER'S REPRESENTATIVE

PART 2 - PRODUCTS (Not Used)

PART 3 - EXECUTION (Not Used)

END OF SECTION 013523



SECTION 017700 – CLOSEOUT PROCEDURES

PART 1 - GENERAL

1.1 SUMMARY

- A. This Section includes administrative and procedural requirements for contract closeout.

1.2 SUBSTANTIAL COMPLETION

- A. Preliminary Procedures: Before requesting inspection for determining date of Substantial Completion complete the following. List items below that are incomplete in request.
1. Prepare a list of items to be completed and corrected (punch list), the value of items on the list, and reasons why the Work is not complete.
  2. Submit specific warranties, workmanship bonds, maintenance service agreements, final certifications and similar documents.
  3. Obtain and submit releases permitting Owner unrestricted use of the Work and access to services and utilities. Include occupancy permits, operating certificates, and similar releases.
  4. Deliver tools, spare parts, extra materials, and similar items to location designated by Owner. Label with manufacturer's name and model number where applicable.
  5. Terminate and remove temporary facilities from Project site, along with mockups, construction tools, and similar elements.
  6. Touch up and otherwise repair and restore marred exposed finishes to eliminate visual defects.
  7. Submit certificate of manufacturer's inspection.
- B. Inspection: Submit a written request for inspection for Substantial Completion. On receipt of request, Architect will either proceed with inspection or notify Contractor of unfulfilled requirements. Architect will prepare the Certificate of Substantial Completion after inspection or will notify Contractor of items, either on Contractor's list or additional items identified by Architect, that must be completed or corrected before certificate will be issued.
1. Reinspection: Request reinspection when the work identified in previous inspections as incomplete is completed or corrected.
  2. Results of completed inspection will form the basis of requirements for Final Completion.

1.3 FINAL COMPLETION

- A. Refer to General Conditions Article 14.3.
- B. Preliminary Procedures: Before requesting final inspection for determining date of Final Completion, complete the following:
1. Submit a final Application for Payment.

2. Submit certified copy of Architect's Substantial Completion inspection list of items to be completed or corrected (punch list), endorsed and dated by Architect. The certified copy of the list shall state that each item has been completed or otherwise resolved for acceptance.
- C. Inspection: Submit a written request for final inspection for acceptance. On receipt of request, Architect will either proceed with inspection or notify Contractor of unfulfilled requirements. Architect will prepare a final Certificate for Payment after inspection or will notify Contractor of construction that must be completed or corrected before certificate will be issued.
  1. Reinspection: Request reinspection when the Work identified in previous inspections as incomplete is completed or corrected.

#### 1.4 LIST OF INCOMPLETE ITEMS (PUNCH LIST)

- A. Preparation: Submit three copies of list. Include name and identification of each space and area affected by construction operations for incomplete items and items needing correction including, if necessary, areas disturbed by Contractor that are outside the limits of construction.

#### 1.5 CORE SAMPLES

- A. The Owner reserves the right to have core sampling performed by the Contractor where moisture contamination is suspected within the new roof system until the expiration of the Contractor's warranty. Core sample locations shall be chosen by the Owner and be performed at no cost to the Owner.

#### 1.6 WARRANTIES

- A. Submittal Time: Submit manufacturer's warranties and contractor's guarantees on request of Architect for designated portions of the Work where commencement of warranties other than date of Substantial Completion is indicated.

#### 1.7 PROJECT CLOSEOUT SUBMITTALS

- A. When both the Owner or Owner's Representative and the Manufacturer's Representative agree that the Contractor has performed according to the Specifications and has installed the materials to the satisfaction of the Manufacturer, submit the following:
  1. Specified Contractor's and Manufacturer's Warranties and Guarantees.
  2. Lien Releases from Contractor, subcontractor, and suppliers (AIA Forms G706, G706A).
  3. Consent of Surety to Final Payment (AIA Form G707).

### PART 2 – PRODUCTS

#### 2.1 MATERIALS

- A. Cleaning Agents: Use cleaning materials and agents recommended by manufacturer or fabricator of the surface to be cleaned. Do not use cleaning agents that are potentially hazardous to health or property or that might damage finished surfaces.

PART 3 – EXECUTION

3.1 FINAL CLEANING

- A. General: Provide final cleaning. Conduct cleaning and waste-removal operations to comply with local laws and ordinances and Federal and local environmental and antipollution regulations.
- B. Comply with safety standards for cleaning. Do not burn waste materials. Do not bury debris or excess materials on Owner's property. Do not discharge volatile, harmful or dangerous materials into drainage systems. Remove waste materials from Project site and dispose of lawfully.

END OF SECTION 017700

SECTION 142400 - HYDRAULIC ELEVATOR

**PART 1 - GENERAL**

1.1 WORK INCLUDED

- A. To renovate one passenger hydraulic elevator located in the Strathmore Mansion 10701 Rockville Pike, Rockville, Maryland as shown on attached drawings and as hereinafter specified. This shall include, but not be limited to the following:

1. Replace jack assembly
2. Replace controls
3. Replace buffers
4. Replace corridor control stations and signals
5. Replace car enclosure
6. Replace door operator & protection system
7. Replace car control station and signals
8. Replace pump unit and piping

Materials, equipment and installation shall be such to specifically address use and environmental conditions associated with those found at the site.

- B. Coincidentally with the progress of replacing various systems, all reused material shall be checked, modified and repaired or replaced, if necessary, so each item is equal in condition to that of a new item.
- C. Everything required to satisfactorily complete elevator installation as required by contract documents.
- D. Removal and disposal of existing elevator equipment which is not reused or as ~~specifically noted herein.~~
- E. Cleaning, inspection, repair and replacement of components. Refurbishing and lubrication/painting of existing equipment which is retained and reused. (Such equipment must be compatible with new systems and components.)
- F. Provide preventive maintenance and repair services on all elevators associated with this specification to retain the elevator equipment and performance in "like new" condition beginning with the Notice to Proceed and continuing for a period of 24 months after the date of "Final" acceptance of all work associated with this contract.

1.2 RELATED WORK

A. Existing

1. Hoistway and Pit:
  - a. Existing hoistway.
2. Machine Room:
  - a. Existing machine room enclosure.

B. To be provided by Contractor

1. Hoistway and Pit:
  - a. Proper patch of all areas of hoistway wall construction to retain 2-hour fire rating.
  - b. Provide clean dry pit.
  - c. Provide sprinkler in accordance with NFPA 13.
  - d. Provide pit access ladder.
  - e. Provide new bar grating for secondary pit level.
2. Machine Room:
  - a. Provide all necessary heating and cooling to the present machine room to maintain proper environmental conditions between 55 degrees F and 90 degrees F and not to exceed 85 percent relative humidity regardless of exterior weather conditions. Submit details of proposed design along with supporting information for the design selected for approval.
  - b. Proper patch of all areas of machine room construction to retain fire rating.
  - c. Temporally remove fan unit and duct work located outside of the machine room entrance to provide a clear path for the removal and installation of elevator equipment. Reinstall duct work and fan unit when the installation of the new elevator equipment is complete.
3. Electrical:
  - a. GFCI type convenience outlets in elevator pits and machine room.
  - b. Modify existing smoke sensors system in each elevator lobby, hoistway and machine room to operate Firefighters' return feature as required by applicable Codes.
  - c. Provide proper machine room and pit lighting.

- d. Power feeders to elevator controller for lighting and exhaust blower. Individual disconnect switch at machine room location shown on Elevator Contractor shop drawings.
- e. Public telephone system connections to elevator control panels in elevator machine room.
- f. 3-phase mainline switch. Switch to include an auxiliary contact that will be open when switch is in "off" position.

### 1.3 DEFINITION OF TERMS

- A. Words in the singular shall include the plural whenever applicable or the context so indicates.
- B. All terms in these specifications have the definition given in the latest edition of the American National Standard Safety Code for Elevators and Escalators ASME A17.1.

### 1.4 QUALITY OF ASSURANCE

- A. General: It is the County's intent to enter into a contract with a complete full service contractor specializing in vertical transportation and elevator maintenance, modernization, restoration, repair, testing and service regardless of the manufacture, make, style, size or age of the equipment. This company must have licensed and certified elevator repair technicians as part of their regular full-time staff for the maintenance, modernization, restoration, repair, testing and service of elevator and vertical transportation systems and the associated remote monitor system in its various facilities throughout Montgomery County, Maryland as specified in this solicitation. The company must have as part of their regular full time staff, an emergency dispatch service which will provide 24 hour emergency call back service with a guaranteed prompt response regardless of the time of day or night in which service is requested. The company must have an in house parts inventory of replacement components at their services location or warehouse and all maintenance personnel must be equipped with an on-hand inventory of commonly used replacement parts on their company supplied service vehicles. The company must have on staff NEIEP (National Elevator Industry Education Program) trained service technician(s) with national QEI (Qualified Elevator Inspector) certification(s) as licensed Elevator/Escalator Inspector(s). In addition, the company must have at least five (5) years of experience in the vertical transportation and elevator maintenance, modernization, restoration, repair and service industry.

Safety and reliability are of paramount importance in the maintenance of all devices and equipment inasmuch as they serve vital County installations which serve the public. Effective maintenance to minimize interruptions shall be the key areas of concentration of the offeror. Anything falling short of these objectives falls short of the requirements of the specification.



B. Approved Manufacturers:

1. Hydraulic Elevators: Canton Elevator Inc., Minnesota Elevator Inc. ThyssenKrupp Elevator.
2. Car Enclosures: Columbia Elevator Products Co., ECI, Elevator Modernization Company Inc., Globe Van Doorn, Gunderlin, Hauenstein & Burmeister, Tyler.
3. Hoistway Entrances: Canton Elevator Inc., Columbia Elevator Products, Elevator Doors, Minnesota Elevator Inc.
4. Control: Motion Control.
5. Operating & Signaling Devices: EPCO, GAL, Innovation Industries, Monitor Controls, PTL Equipment Manufacturing.

Other Manufacturers may be considered. Provided a written request for approval has been submitted by the Awarded Contractor and has been received by the Owner no later than ten days from the Notice to Proceed. Each such request shall include a complete description of the Manufacturers qualifications, along with descriptions of proposed alternate equipment. The burden of proof of the merit of the proposed substitute is upon the proposer. The Owner's decision of approval or disapproval of a proposed alternate Manufacturer and equipment shall be final.

- C. Non-Proprietary Equipment: All equipment shall be of the non-proprietary type. Equipment that must be maintained, serviced and adjusted by the original equipment manufacturer shall be considered proprietary. This also includes equipment that requires use of tools and equipment along with instructions for their use that are not available to the Owner.
- D. Document Verification: In order to discover and resolve conflicts or lack of definition which might create construction problems, Elevator Bidders must review contract documents and existing conditions for compatibility with their products prior to bidding. Bidder's compliance with all provisions of contract documents is assumed and required. Owner will not pay for changes to structural, mechanical, electrical or other systems required to accommodate Bidders' equipment.
- E. Measurements and Drawings: Any drawings or measurements included with the bidding material shall be for the convenience of the bidders only. Complete responsibility for detailed dimensions lies with the Contractor. In the execution of the work on the job, the Contractor is to verify all dimensions with the actual conditions. Where the work of one trade is to join another trade, the shop drawings shall show the actual dimensions and the method of joining the work of the two trades.

- F. Compliance with Regulatory Agencies: Comply with most-stringent applicable provisions of following Codes and/or Authorities, including revisions and changes in effect on date of these specifications:
1. Safety Code for Elevators and Escalators ASME A17.1 - 2016.
  2. Guide for Inspection of Elevators, Escalators and Moving Walks ASME A17.2.2 - 2014.
  3. Safety Code for Existing Elevators and Escalators, ASME A17.3 – 2015.
  4. National Electrical Code, NFPA 70 - 2014.
  5. Life Safety Code, NFPA No. 101 - 2015 and local fire authority.
  6. Requirements of International Building Code (IBC) and any other Codes, Ordinances and Laws applicable within the governing jurisdiction.
  7. Providing Accessibility and Usability for Physically Handicapped People, ANSI A117.1.
  8. Accessibility Guidelines for Buildings and Facilities issued July 26, 1991 by the United States Architectural and Transportation Barriers Compliance Board.

G. Warranty:

1. Materials and workmanship of the elevator installation shall comply in every respect with contract documents. Unless due to improper use or care by Owner, correct defects which develop within two years from date of final acceptance of work to the satisfaction of the Owner, at no additional cost.
2. Make modifications, adjustments, improvements, etc., to meet performance requirements in Parts 2 and 3 of this specification.

## 1.5 TEST AND INSPECTIONS

- A. Perform pre-inspection and tests as well as tests required by the Governing Authority and/or the ASME A17.1 Safety Code for Elevators and Escalators, with procedures described in ASME A17.2 Guide for Inspection of Elevators, Escalators, and Moving Walks.
- B. Supply personnel and equipment for tests and final reviews indicated in Part 3 of this specification at no added cost.

- 1.6 PROTECTION OF WORK AND PROPERTY: The Contractor shall continuously maintain adequate protection of all his work from damage and shall protect the Owner's property from injury or loss arising out of this contract. The Contractor shall make good any such damages, injury or loss, except such as may be directly caused by agents or employees of the Owner. The Contractor shall provide all barricades required to protect open hoistways or shafts. Enclosures shall be constructed of nonperforated material, enclose the complete work area without interfering with normal activity, extend floor to ceiling, be securely fastened in place, outside surfaces shall be relatively smooth and

painted and, if access through the enclosure is necessary, the access shall be self-closing and lockable. In addition, barricades shall meet OSHA regulations.

1.7 WORK AREA

- A. Contractor will be provided work area at the job site with convenient access to the elevators. Space provided will be approximately 26' x 18'. Any additional off-site space required is the responsibility of the Contractor.
- B. Allocate the available work areas and coordinate their use with the other trades on the job. Maintain a current layout of all areas.
- C. Contractor will be responsible for barricading and securing the area from public access.
- D. Contractor will be responsible for signage directing the public to the operational elevators during construction.

1.8 REMOVAL OF DEBRIS AND RUBBISH: The Contractor shall remove and properly dispose of all debris, rubbish as fast as it accumulates, keeping the building and premises clean during the progress of work and leave the premises at completion in perfect condition as far as his work is concerned to the Owner's complete satisfaction.

1.9 MATERIALS AND WORKMANSHIP: All materials and equipment furnished shall be new and the best of their respective kinds to address use and environmental conditions associated with those found in this type structure. Installation shall be in a neat, accurate, workman like manner and be subject to the approval of the Owner. All materials and equipment provided shall conform to the regulations of the bodies having jurisdiction. The Contractor shall furnish for approval all samples as directed and material shall be in accordance with approved samples.

1.10 REMOVAL OF EXISTING EQUIPMENT: All existing elevator equipment which is not to be used in the modernization shall be removed by the Contractor and immediately become his property.

1.11 CARTAGE AND HOISTING

- A. All required hoisting and movement to, on and from the job site of new equipment, reused equipment or removal of existing equipment shall be the responsibility of the Contractor.
- B. Materials, products and equipment shall be properly packaged and protected to prevent damage during transportation and handling.

- 1.12 REUSED EQUIPMENT: All equipment which is reused shall be refurbished in a manner to address use and environmental conditions associated with those found in this type facility and included in the two-year warranty.
- 1.13 CERTIFICATE OF INSPECTION: Contractor shall arrange and pay for any necessary inspections by governing authorities, certificates of inspection and permits necessary for operation of the elevators by the Owner and conduct regularly scheduled inspections during the term of the maintenance agreement.
- 1.14 GUARANTEE OF WORK: Contractor shall guarantee that the materials and workmanship of the apparatus installed by them under this contract shall meet specified requirements in every respect and that they will make good any defects not due to improper use, which may develop within two years from the date of final acceptance of all equipment. Neither the final payment nor any provision of the contract documents shall relieve the Contractor of the extent and period provided by law and upon written notice he shall remedy any defects due thereto and pay all expenses for any damage to other work resulting there from.
- 1.15 PROGRESS OF WORK
- A. Upon Notice to Proceed, the Contractor shall, within fourteen (14) calendar days, submit for approval complete project schedule, including equipment delivery dates, plan of individual efforts, sequence of efforts, manpower, etc. based on the information submitted on the bid form. When an elevator is removed from service, all work shall be completed, inspected and accepted prior to removal of another elevator from service. The Contractor is expected to maintain this schedule. Any deviations to the program require 7 day prior notice and must include revised schedule for approval.
- B. The Contractor shall submit in writing the following information to the Owner throughout the construction period:
1. Request for Information regarding specifications, drawings or job conditions requiring action of the Owner shall be faxed to the Owner's office. A prompt response will be given to prevent delays.
  2. A bi-weekly progress report of job status showing compliance with approved schedule. Any deviations will be specifically noted with actions taken to maintain completion.
  3. A progress report with the submission of each payment request showing the progress being made and the percentage of the job completed and shall certify to the Owner that labor and materials listed on the request for payment have been performed or installed or verified in storage.

1.16 SUBMITTALS

- A. Within 30 days following notice to proceed with the work, Contractor shall submit, and have approved, calculations, layouts, shop drawings and standard cuts as noted hereafter.
- B. Drawings:
  - 1. Contractor shall submit one reproducible and three print copies of hoistway plan, machine room plan, hoistway and machine room section and lobby entrance elevation layout drawings, car enclosure layout and details, accessory and fixture drawings, details and finish samples to the Owner for review. One print copy/sample shall be returned to the Contractor within 14 days of transmittal date.
  - 2. Acknowledge and/or respond to drawing markup within 7 days of return; promptly incorporate required changes so that delivery and installation schedules are not affected. Revision response is not justification for delay.
- C. Calculations:
  - 1. Electrical requirements necessary to verify adequacy of existing electrical provisions.
  - 2. Retained equipment adequacy if car weight modified by more than 5% per Code.

#### 1.17 COMPLETION DOCUMENTATION AND EQUIPMENT

- A. Drawings: At the conclusion of the job, submit a reproducible copy of all final drawings previously described under Submittals. The drawings shall reflect AS INSTALLED conditions. (Reproducible set shall be Mylar master.)
- B. Wiring Diagrams:
  - 1. One complete reproducible and four print sets of AS INSTALLED straight-line wiring diagrams, showing the electrical connections of all elevator equipment in the hoistway as well as the machine room, shall be furnished upon completion. (One set of diagrams shall be reproducible Mylar master.) Provide and continually update this set to reflect any changes made. (These diagrams shall become the Owner's property.)
  - 2. A legend sheet shall be furnished with each set of drawings containing the following information:
    - a. Name and symbol of each component.
    - b. Location on drawings, drawing sheet number and area of component.



- c. Location of apparatus whether on controller, selector, starter, hoistway or elevator car.
- C. Printed Instructions: The following printed information shall be furnished for all new and reused equipment upon completion. Material shall be based on manufacturer's requirements. The documents shall include a table of contents and locator tabs:
1. Three sets of neatly bound instructions explaining all operating features including all apparatus in the car and lobby control panels.
  2. Three sets of neatly bound maintenance and adjustment instructions explaining areas to be addressed, methods and procedures to be used, and specified tolerances to be maintained for all equipment. Include instructions for use, calibration, repairs and replacement for all tools and instruments used adjusting and accessing operational systems.
  3. Three lubrication charts indicating all lubricating points, frequency of lubrication, methods for application and type of lubricant recommended for all equipment. Provide lubricant specification or acceptable lubricant manufacturer with corresponding identification information.
  4. One maintenance log to be placed in respective machine room. One copy shall also be incorporated into bound maintenance and adjustment instructions. Log shall list the various items requiring examination, the procedure to be followed, the frequency of the examination and place to record compliance with the recommended procedure. The log shall cover a period of at least one year. At the end of each year, the log shall be returned to the Owner and a copy of the log for the next year will be provided by the Owner. The logs are the property of the Owner and will remain so.
  5. One maintenance and call back log for the machine room. The log shall provide a permanent record of visits. The log shall indicate the date of the visit, person making the visit, unit involved, reason for the visit and work accomplished. One copy shall also be incorporated into bound maintenance and adjustment instructions. The log shall cover a period of at least one year. At the end of each year, the log shall be returned to the Owner and a copy of the log for the next year will be provided by the Owner. The logs are the property of the Owner and will remain so.
  6. Hydraulic fluid replacement log for each elevator to be placed in respective machine room. The log shall indicate date when fluid was added, amount added, person making the addition and reason for additional fluid. One copy shall be incorporated into bound maintenance and adjustment instructions. The log shall cover a period of at least one year. At the end of each year, the log shall be returned to the Owner and a copy of the log for the next year will be provided by the Owner. The logs are the property of the Owner and shall remain so.



7. One Firefighters' Service Test Log to comply with requirements of Section 8.6.10.1 of ASME A17.1. Log shall be placed in respective machine room. One copy shall also be incorporated into bound maintenance and adjustment instructions. The log shall cover a period of at least one year. At the end of each year, the log shall be returned to the Owner and a copy of the log for the next year will be provided by the Owner. The logs are the property of the Owner and will remain so.
  8. Three complete parts catalogs for all replaceable parts. Catalog shall identify parts by names and location, and information required for ordering. It shall also include a list of recommended parts, with suggested quantities, to be maintained. List shall identify components unique to project, failure of which could result in extended down time, or loss of which could require extended time period for replacement.
  9. Two copies of complete elevator function charts delineating each specific elevator function such as Automatic Operation, Inspection Operation, Parking, Independent Service, Firefighters' Operation, Standby Power Operation and Security Controls.
  10. The Contractor shall submit all information to the Owner for approval.
- D. Keys: Three sets of keys to operate all keyed switches and locks shall be furnished to the Owner upon completion. Each key shall be properly identified with a metal or plastic tag bearing key application. The tag shall be securely attached to the key. All keying shall be coordinated with the Owner.
- E. Spare Parts Cabinet: Provide metal cabinet for storage of parts and lubricants.
- F. Maintenance and Adjustment Tools and Equipment: Provide at least 1 set of any and all tools and equipment not commercially obtainable in the open market along with means for calibration, repairs, replacement, etc. to the Owner. Provide two sets of written documentation on proper use and maintenance of all maintenance and adjustment tools to the Owner. All materials shall be usable by the Owner or his/her designated representative designated to perform maintenance, service and/or adjustment functions. Tools and equipment shall allow access for all levels of monitoring, trouble shooting, adjusting and diagnostic procedures. Equipment shall contain non-volatile components or software. Replacement parts, literature and future servicing of items provided shall be made available to the Owner at a fair market price.

#### 1.18 MANUFACTURER'S NAMEPLATES

- A. Manufacturer's name plates and other identifying markings shall not be affixed on surfaces exposed to public view unless approved by the Owner.

- B. This requirement does not apply to Underwriter's Laboratories and Code required labels where required. Each major component of mechanical and electrical equipment shall have, on a securely attached plate, the manufacturer's name, address, model number, rating and any other information required by governing codes.

#### 1.19 MATERIALS

A. Steel:

1. Sheet Steel (Furniture Steel for Exposed Work): Stretcher-leveled, cold-rolled, commercial-quality carbon steel, complying with ASTM A366, matte finish.
2. Sheet Steel (for Unexposed Work): Hot-rolled, commercial-quality carbon steel, pickled and oiled, complying with ASTM A569.
3. Structural Steel Shapes and Plates: ASTM A6, ASTM A36, and ASTM A108.

B. Stainless Steel:

1. Type 302 or 304 complying with ASTM A167, with standard tempers and hardness required for fabrication, strength and durability.
2. Apply mechanical finish on fabricated work in the locations shown or specified. (Federal Standard and NAAMM nomenclature), with texture and reflectivity required to match Architect's sample. Protect with adhesive-paper covering. No. 4 bright directional polish (satin finish). Graining directions as shown or, if not shown, in longest dimension.

C. Plastic Laminate: ASTM E84 Class A and NEMA LD3, Fire-Rated Grade (FR-50), Type 7, 0.050" +/- .005 inches thick; color and texture as follows:

1. Exposed Surfaces: Color and texture selected by Owner.
2. Concealed Surfaces: Manufacturer's standard color and finish.

D. Fire-Retardant Treated Plywood or Particle-Board Panels: Minimum 3/4 inch thick backup for natural finished wood, and plastic laminate veneered panels, edged and faced as shown, provided with suitable anti-warp backing; meet ASTM E84 Class "I" rating with a flame spread rating of 25 or less, registered with Local Authorities for elevator finish materials.

E. Paint: Clean exposed metal of oil, grease, scale and other foreign matter and factory paint one coat of Manufacturer's standard rust-resistant primer. After erection, provide one finish coat of Industrial enamel paint. Galvanized metal need not be painted.

- F. Prime Finish: Clean all surfaces receiving a baked enamel finish of oil, grease, scale, etc. Apply one coat of rust-resistant paint followed by a filler coat over uneven surfaces. Sand smooth and apply final coat.
- G. Baked Enamel: Prime per paragraph F above. Apply and bake 3 additional coats of enamel in the color selected by Owner.
- H. Entrance Field Painting: Clean all surfaces of dirt and grease. Sand as necessary to remove pits and scratches and prepare surface for painting. Apply filler to insure smooth surface, sand and apply one coat of electrostatic enamel in the color selected by Owner.
- I. Refinishing of Natural Metals: Remove existing protective finish. Buff as necessary to remove scratches, regrain and/or finish as specified. Protect as indicated for particular metal type.

#### 1.20 PROTECTION

- A. Provide, erect and maintain catch platforms, lights, barriers, weather protection, warning signs and other items as required for proper protection of the public, occupants of the building, workmen engaged in work and adjacent construction.
- B. Provide and maintain weather protection at exterior openings so as to fully protect the interior premises against damage from the elements until such openings are closed by new construction.
- C. Provide and maintain temporary protection of the existing structure designated to remain where removal and new work is being done, connections made, materials handled or equipment moved.
- D. Take necessary precautions to prevent dust from rising by wetting removed masonry, concrete, plaster and similar debris. Protect unaltered portions of the existing building affected by the operations under this Section by dustproof partitions and other adequate means.
- E. Provide adequate fire protection in accordance with local Fire Department requirements.
- F. Do not close or obstruct walkways, passageways or stairways. Do not store or place materials in passageways, stairs or other means of egress. Conduct operations with minimum traffic interference.
- G. Be responsible for any damage to the existing structure or contents by reason of the insufficiency of protection provided.

1.21 WORKMANSHIP

- A. Perform removal and alteration work as shown, with due care, including shoring, bracing, etc. Be responsible for damage, which may be caused by such work, to any part or parts of existing structures or items designated for reuse. Perform patching restoration and new work as applicable.
- B. Execute the work in a careful and orderly manner, with the least possible disturbance to the public and to the occupants of the building.
- C. Where alterations occur, or new and old work join, cut, remove, patch, repair or refinish the adjacent surfaces to match condition which existed prior to commencement of the work. The materials and workmanship employed in the alterations, unless otherwise shown or specified, shall comply with that of the original work. Alteration work shall be performed by the various respective trades which normally perform the particular items of work.
- D. Finish new and adjacent existing surfaces as specified for new work. Clean existing surfaces of dirt, grease, loose paint, etc. before refinishing.
- E. Where existing equipment and fixtures are indicated to be retained, repair such equipment and fixtures to "like new" condition. Refinish as directed.
- F. Remove all debris as the work progresses. Maintain the premises in a neat and clean condition.

1.22 MAINTENANCE

- A. Statement of Task: The Contractor shall furnish a preventive maintenance program which will place and retain the elevator equipment and performance in a "like new" condition. The program shall clean, properly lubricate, replace worn and defective components prior to failure and make necessary adjustments to assure peak performance and maximum life of the equipment and installation. It is intended that equipment related shutdowns will be kept to an absolute minimum. Should they occur, the Contractor shall respond and make necessary repairs and adjustments. The maintenance program shall include the conditions here in specified and shall be in conformance with requirements of Section 8.6 of ASME A17.1.
- B. Period of Coverage: The Contractor shall assume responsibility for, based on conditions at that time and furnish preventive maintenance and service on the operating elevators described herein beginning at the notice to proceed and continuing for a period of 24 months, after the date of "Final" acceptance of all work associated with this contract.

- C. Cost: The cost for all maintenance and 24-hour call back service is included in this contract and shall be included in the base bid.
- D. Security Provisions:
1. All security requirements established by the using agency for its facility shall become a part of these specifications. It shall be the Contractor's responsibility to comply with any special security provisions established.
  2. At the conclusion of each visit, all keys shall be returned to the Owner or his/her designed representative. They shall not be removed from the building.
- E. Working Hours: Regular service work, which does not interfere with the elevator operation, shall be performed during normal working hours (9:00 A.M. - 3:30 P.M. Monday thru Friday). Elevator shall not be removed from service prior to 9:00 A.M. or after 3:30 P.M. Work outside normal working hours work must be coordinated and approved by the Owner or his/her designated representative.
- F. Local Conditions Covering Work:
1. The Contractor shall cooperate with those in authority on the premises to prevent the entrance and exit of all workmen and/or others whose presence is forbidden or undesirable and in bringing, storing or removal of all materials and equipment, (to observe all County rules and regulations in force), to avoid unnecessary dust, or accumulated debris or the undue interference with the convenience, sanitation or routine of the public and Owner (and to prevent the loss of, or damage to the property of the Owner). The Contractor shall repair any and all damage he/she may cause to the building or property, to the full satisfaction of the Owner.
  2. Contractor shall maintain the machine room, machinery spaces, hoistways, cars and pits in reasonably clean condition at all times. Equipment shall be properly protected to prevent damage as result of environmental conditions. If damage does occur, surfaces shall be properly cleaned, remove damage and properly treat to prevent continued damage.
- G. Breakdowns and Shutdowns: The Contractor shall have sufficient manpower, expertise, technical support and materials available to limit breakdowns and shutdowns as specified below.
1. Breakdowns and shutdowns, such as electrical troubles, burned out control coils, open circuits, electrical or mechanical adjustments, will not keep the respective elevator out of service longer than one (1) day (24 hours).
  2. Under no circumstances will any shutdown or breakdown last longer than three (3) days (72 hours). This includes the locating of the trouble, procurement of



parts, the installation of these parts and the replacing of the respective elevator back into safe uninterrupted operation.

3. The Contractor must be so equipped to meet the above conditions. The excuse of not being able to obtain parts, necessary technical and engineering advice, etc., will not be acceptable, and the Contractor will be considered in default, giving sufficient justification to the Owner to obtain these services from Contractors who can provide the Owner with uninterrupted elevator service.
4. The Owner may take over the work and prosecute it to completion by contract or otherwise, and the Contractor and his/her sureties (if any), shall be liable to the Owner for any additional cost occasioned by the Owner, previous to the termination of the contract.

H. Parts and Material Inventory:

1. The Contractor shall maintain a supply of contacts, coils, leads, fuses, valve parts, hanger rollers, clutch rollers, lubricants which meet original equipment manufacturer's specifications, wiping cloths, and other minor parts for the performance of routine preventive maintenance properly stored in the elevator machine room.
2. The Contractor shall also maintain a supply of spare lending and replacement parts in their warehouse inventory. This inventory shall include all parts listed in the manufacturer's recommended spare parts lists and any other parts and materials necessary to maintain these elevators as herein specified.
3. All replacement parts and materials shall be specifically designed for the elevators on which they are to be used. The Contractor shall provide for replacement parts and lubricants from the original manufacturer of the elevator equipment or approved suppliers of such original manufacturer's parts. Substitute parts may not be utilized unless prior approval of the Owner is obtained.

I. Technical Standards: The items, materials, or appliances required by this specification must conform to the ASME A17.1 - 2016 Safety Code for Elevators and Escalators with Supplements, the standards of the ASME A17.2 - 2014 Guide for Inspection of Elevators, Escalators and Moving Walks, ASME A17.3 - 2015 Safety Code for Existing Elevators and Escalators with supplements and the CAN/CSA-B44-M91, ASME A17.5 - 2014 Elevator and Escalator Electrical Equipment.

J. Owner's Right of Inspection and Test: The Owner reserves the right to make or cause to be made, such inspections and tests, as deemed advisable, to ascertain that the requirements of these specifications are being fulfilled. Should it be found that the standards herein specified are not being satisfactorily maintained, the Owner may immediately demand that the Contractor place the elevators in a condition to meet those requirements. If the Contractor fails to comply with such demands, within a



three (3) day (72 hours) time period, the Owner may, by written notice to the Contractor, terminate his right to proceed further with the work. In such event, the Owner may take over the work and prosecute it to completion, by contract or otherwise, and the Contractor and his sureties (if any), shall be liable to the Owner for any additional costs occasioned by the Owner.

K. Periodic Visits to the Site: The Contractor shall make no less than monthly preventive maintenance visits to the site for the purpose of performing all preventive maintenance tasks, adjustments and service requirements as recommended by the elevator manufacturers and as indicated on the preventive maintenance charts, lubrication charts and schedules.

L. Demand Visits to Site:

1. The Contractor shall also provide call back service within two (2) hours of notification by the Owner for any conditions that require adjustments or repair.
2. Emergency service shall be rendered within (30) minutes or less from the time a call is placed for emergency service. Emergency services shall be requested for the following conditions:
  - a. Shutdowns involving entrapments.
  - b. Situations involving injury or hazardous conditions.
  - c. Fire or other emergency conditions.

Emergency calls shall be so identified by the Owner at the time of the call.

3. The Contractor shall also provide maintenance, adjustments and/or repairs to comply with any violation of the Governing Agencies and recommendations of casualty companies on due notice from the Owner.

M. Service Records:

1. It shall be the responsibility of Contractor's service personnel to log in and out, where directed by the Owner, each time he/she visit the site for either a routine or demand service check.
2. Upon completion of the work, service personnel shall record required information on the Maintenance log (See paragraph 1.17,C,4), Maintenance call back log (See paragraph 1.17,C,5) and/or Firefighters' Service test log (See paragraph 1.17,C,7).
3. An itemized service ticket indicating the work accomplished shall be left with the Owner after each visit. Service tickets shall be clearly legible and include complete description of work done. In the case of a call back, ticket shall also include a description as to the nature of the call.

N. Repairs and/or Renewals:

1. The Contractor shall be responsible for all necessary repairs, adjustments and parts renewal to all elevator components including periodic static loading of the car as required to verify and, if necessary, set automatic control limit devices.
2. Repairs or renewals necessitated by accidents, misuse, storm, fire, flood, or water damage, or due to any other cause beyond the Contractor's control shall be the responsibility of the Owner. When the Contractor feels it is this type work to be accomplished, they shall notify the Owner immediately. Notification shall include description of work and cost. Authorization for the Contractor to accomplish such work shall be provided in writing by the Owner. Written notification confirming verbal description, cost and name of person authorizing work, if applicable, will be provided.
3. The Contractor shall be responsible for repairs or renewals of machine room enclosure and shaftway enclosure necessitated by contractor's negligence, accidents or misuse.
4. The Contractor shall be responsible for coordinating and performing all required safety testing and monthly testing of Firefighters' Service as required by ASME A17.1 Section 8.6.10.1.

O. Contractor's Responsibility: When the Owner finds it necessary to request immediate service from the Contractor in order to repair improper operation or nonperformance of the elevator, this service and repair will be considered by the Owner as a reoccurring maintenance problem that is the responsibility of the Contractor. The cost of this service and repair when performed shall be borne by the Contractor. If the Contractor can prove, to the Owner's satisfaction, that this problem was not a maintenance problem covered in the contract specifications, the Contractor may charge the Owner for the additional service performed at the respective billing rate. When the above Contractor's service is requested after normal working hours (7:30 A.M. - 4:00 P.M. Monday through Friday except designated holidays), the Contractor must respond to this request by rendering service within two (2) hours after the request is made.

P. Liability: The Contractor shall not be held responsible for non-operation of said equipment by reason of fire, flood, acts of civil or military authorities, or by insurrection or riot.

Q. Miscellaneous Agreements:

1. If the Contractor fails to perform the work in accordance with the specifications as interpreted by the Owner without reasonable justification, the Contractor will be considered to be in default and thereby shall make it necessary for the Owner to obtain these services from Contractors who can provide the Owner with the required services.

2. The Owner may take over the work and prosecute it to completion by contract or otherwise, and the Contractor and his sureties (if any) shall be liable to the Owner for any additional cost occasioned by the Owner previous to the termination of this contract.
3. The Contractor shall maintain, on site, the Owner's detailed service logs for each elevator. These service logs must be kept in the machine room. Completed annual logs shall be returned to the Owner.
4. The Contractor will maintain and retain all records and documents relating to the performance of the Contract for a period of three years after completion of the contractual services and will make such records available for audit and inspection by the Owner.

R. Preventive Maintenance:

1. The Contractor shall be responsible for determining the proper number of hours per month to perform the necessary preventive maintenance tasks based on equipment manufacturer's recommendations, environmental conditions and experience; however, they shall provide a minimum number of hours per month to perform these tasks as follows:

3 hours per elevator

2. Maintenance, repairs or replacement of the following elevator equipment, is not to be considered as part of the minimum number of hours for performing preventive maintenance as previously stated:
  - a. Performing tests, as required by the Owner, shall be additional required work man-hours by the Contractor at no cost to the Owner.
  - b. Repairs and/or renewals made at Owner's direction.
  - c. Adjustments, repairs, and/or renewals made in conjunction with requirements of previous paragraphs L and N of this section.
  - d. Demand visits to site.

- S. Job Supervisor: The Contractor shall indicate one person who shall be responsible for the scheduling control and performance of work specified in the Contract. This person shall be available upon request by the Owner to review any aspect of this contract. The Contractor shall notify the Owner if there is a change in job supervisors.

## PART 2 - PRODUCTS

### 2.1 Summary

A. Passenger Elevator Number 1:

|                          |  |
|--------------------------|--|
| Capacity:                | 4500 Pounds  |
| Speed:                   | 125 FPM  |
| Operational Control:     | Selective Collective with<br>Microprocessor-Logic System         |
| Motor Control:           | Hydraulic Solid State Starting                                   |
| Stops:                   | 3  |
| Openings:                | 3  |
| Floors Served:           | G-1-2  |
| Travel: (Approx.)        | 21'-1"<br>(To be verified by Contractor)                         |
| Platform Size: (Approx.) | 7'-0" Wide x 5'-1 1/2" Deep                                      |
| Inside Clear Size:       | 6'-8" Wide x 4'-3" Deep with<br>Interior Finishes                |
| Entrance Size:           | 3'-6" Wide x 7'-0" High  |
| Entrance Type:           | Single Speed, Side Opening                                       |
| Entrance Finish:         | Painted Metal  |
| Door Operation:          | To be Replaced   |
| Door Protection:         | Infrared Screen Detector with<br>Differential Timing and Nudging |
| Machine:                 | Direct Connected Hydraulic                                       |
| Guide Rails:             | "T" Type   |
| Buffers:                 | Spring   |
| Car Enclosure:           | As Specified   |

Signals -

Hall Stations: Single Riser, Illuminated Vandal Resistant Buttons, Engraved Use Stair Sign

Car Operating Panel: Illuminated Buttons in Return

Car Position Indicator: Car with Floor Passing Tone

Combination Corridor Position Indicator and Hall Lanterns: Above Entrances at all Floors

Communication System: Self-dialing, Hands-free Telephone, Telephone Box and Shielded Wiring to Car Controller in Elevator Machine Room

B. Common Additional Features:

Roller Guides

Car Top Inspection Station

Emergency Car Lighting and Alarm Battery Pack

Firefighters' Service, Including Alternate Floor Return Feature

Standby Power Source to Lower Elevator to Bottom Floor

Handicapped Accessible

Hoistway Access Switches Mounted in the strike jamb recess at Bottom and Top Floor

Hoistway Door Unlocking Means at all Floors

Independent Service Feature

Car/Jack Unit Isolation

Tamper-Resistant Screws for  
Faceplates

24-Month Maintenance with 24-  
Hour Call Back Service

Machine, and Controller Sound  
Isolation

Wiring Diagrams, Operating  
Instructions and Parts Ordering  
Information

Engraving Filled with Black Paint  
Unless Otherwise Noted

No Visible Company Name or  
Logo

## 2.2 PERFORMANCE

- A. Speed: +/-10% of contract speed under any loading condition.
- B. Capacity: Safely lower, stop and hold up to 125% of rated load.
- C. Stopping Accuracy: +/-1/4" under any loading condition.
- D. Door Opening Time: **3.1 seconds** from start of opening to fully open.
- E. Door Closing Time: **4.0 seconds** measured from the instant the doors begin to close until the doors are fully closed.

The kinetic energy of the hoistway door and all parts rigidly connected thereto (includes the sum of the weights of the hoistway and car doors and related parts) computed for the average closing speed shall not exceed 7 ft. lbs. The force necessary to prevent closing of the hoistway door or car door from rest shall **not exceed 30 pounds**.

- F. Floor-to-Floor Performance Time: **18.0 seconds** from start of doors closing until doors are 3/4 open and car level and stopped at next successive floor under any loading condition or travel direction. (12'-0" average floor height)
- G. Pressure: Do not exceed operating pressure of **350 P.S.I.**



### 2.3 OPERATION

- A. Provide microprocessor-based operating system for a simplex two stop collective automatic elevator to include a series of car call buttons corresponding to the landings served and a single riser of hall call button fixtures with a single hall call button at each terminal landing. The operating devices shall be connected to the microprocessor-based control equipment governing floor selection and direction of travel to provide the operation as specified.

Provide a microprocessor-based system designed to automatically operate the elevator when a car call button has been pressed, provided the hoistway door interlock and car door gate contact circuits have been closed. The elevator shall stop at the floor for which the call has been registered.

In the event that no car call button has been pressed and the car starts up in response a "down" hall call. The "up" hall call shall be served in the same way when the car starts down in response to an "up" call.

If while the car is making an upward trip, a "down" call registered at the landing, no effect shall be obtained during the upward trip, although the call shall remain registered. After the last passenger traveling in the "up" direction has left the car and the door interlock circuit is closed, the elevator shall automatically reverse and start a downward trip collecting passengers at the landing at which the "down" call is registered. Similarly, the downward trip shall not be affected by a registered "up" call. The hall call shall remain registered and answered on the upward trip.

After the car has answered all car and hall calls, the car shall remain at the landing where last dispatched. Hold doors open an adjustable interval (See paragraph 2.7,N and O of this Section.) Cancel initial door open interval when door protective system is actuated, and establish an adjustable door open interval (see paragraph 2.7,N and O of this Section) following actuation of protective system.

- B. On-Site Monitoring: Provide control with on-site monitoring and diagnostic capability. This shall include a cabinet mounted color CRT with accessible keyboard. As a minimum, the system shall be able to display the following:
1. Job Configuration: This report shall provide a brief description of the system, including the programable job name, identification number of car, number of landings, openings per landing, programable landing designation, fire service options and other system options.
  2. System Performance Graph: This report shall provide elevator system performance data based on hall call waiting times. At the end of each hour, the number of up and down hall calls and the up and down waiting time averages shall be calculated and saved in the controller's non-volatile RAM. This information shall be stored for a minimum of seven days.

3. Hall Call Distribution: This report shall provide hourly hall call distribution in a tabular format for each hour, showing the number of hall calls which were answered within 15 to 90 second intervals for each landing and direction, and show the percentage and number of cars that were in service during a specified time frame. This information shall be stored for at least 24 hours.
4. Graphic Display of Elevator Status: This report shall provide a graphic display of the elevator hoistway that gives the user a comprehensive picture of car location, door status, direction of travel, car calls registered, hall calls registered, hall call assignments, estimated time of arrival of a car for a registered hall call, wait time of a registered hall call, floor labels, system status and a car status window. A status window shall be provided that shows the status of the car such as automatic operation, inspection, fire service main and alternate, time out of service, top floor demand and bottom floor demand.
5. Entering Hall and Car Calls: The CRT terminal shall provide a means for entering hall and car calls using the arrow and enter keys. If the call is valid and registered, a corresponding symbol shall be displayed on the screen.
6. Dispatching Parameters: The CRT terminal shall be capable of monitoring and adjusting the dispatching parameters, including, but not limited to, the configurations of parking floors and their priorities, system mode of operation, parking delay times, etc., the system parameters of long hall call wait threshold time and the lobby up peak parameters.
7. Real-Time Clock: The user shall be provided with the capability to program the controller's real-time clock.
8. Car Flags: The CRT shall provide simultaneous viewing of most individual car flags to detect important sequential events.
9. Special Event Calendar Menu: The special event calendar menu shall provide three options. The first, display of Special Event Entries, allows the user to examine the documented faults or events. The second, List and Description of Events, which can be recorded, allows the user to examine the faults and events which are monitored. The third, Initialize the Special Event Calendar, allows the user to clear all the documented faults and events.
  - a. Displayed events shall include but not limited to the following:
    - 1) Fire Service Phase I-Main - The elevator has been placed on Firefighters' Phase I operation and is responding to or at the designated landing.
    - 2) Fire Service Phase I-Alternate - The elevator has been placed on Firefighters' Phase I operation and is responding to or at the alternate landing.
    - 3) Fire Service Phase II - The elevator has been placed on Firefighters' Phase II operation.

- 4) Standby Power Supply - The normal elevator operating supply power has been lost and the standby power source has been placed in service.
- 5) Elevator Operating Supply Power - The normal elevator operating supply power is available and that the mainline disconnect is closed.
- 6) Elevator Lighting Supply Power - The normal elevator lighting supply power is available and that the mainline room car lighting disconnect is closed.
- 7) System Out of Service - Elevator has demand to operate from a hall call but does not respond. Mainline power is available and no planned operational features are activated (i.e., Inspection, Independent Service, Firefighters' Service, ...).
- 8) Car Out of Service - Elevator has demand to operate from a car call but does not respond. Mainline power is available and no planned operational features are activated (i.e., Inspection, Independent Service, Firefighters' Service, ...).
- 9) Inspection - Elevator is operating on In-Car Inspection, Access, or Car Top Inspection Service.
- 10) Independent Service - Elevator is operating on Independent Service control.
- 11) In-Car Stop Switch - The In-car stop switch is open.
- 12) Car Top Stop Switch - The car top stop switch is open.
- 13) Pit Stop Switch - The pit stop switch is open.
- 14) Clock Operation - The clock indicates that the elevator is available for use.

b. Displayed faults shall include but not limited to the following:

- 1) Control Power Out - Normal supply power is available but there is no control power.
- 2) Car On Top Limit - Car on top normal limit.
- 3) Car On Bottom Limit - Car on bottom normal or final limit.
- 4) Car Top Exit - Car top exit is open.
- 5) Car Doors Open with Hoistway Doors Closed - Car door switch open with hoistway door switches closed.
- 6) Car Doors Closed with Hoistway Doors Open - Car door switch closed with hoistway door switch or switches open.
- 7) Door Operator Failure Opening - Door operator has signal to open but does not respond.
- 8) Door Operator Failure Closing - Door operator has signal to close but does not respond.
- 9) Forced Door Closing Failure - The forced door closing feature has been activated but does not reset within 30 seconds of activation.
- 10) Low Oil - Activation of the low oil control.

The system shall include means to incorporate input time delay in order to prevent event registration for bounce signals. The delay shall allow application to any of the events being reported and shall be independently adjusted.

- C. Remote Monitoring: Provide connection to Owner's existing MCE's Imonitor and Ireport system. The system is located at Montgomery County Department of Public Works and Transportation 1301 Seven Locks Road. The elevator control shall, as a minimum, be able to communicate the following information to the remote station either when contacting the elevator with specific requests, or the elevator control provides an automatic, time designated, daily down load of specific events or immediate down load of designated emergency events:
1. Information available upon request from the system: All information listed under paragraph B of this Section.
  2. Information designated for emergency notification:
    - a. Events 1, 2, 3, 4, 7 & 8 listed under paragraph B,9,a of this Section.
    - b. All Faults listed under paragraph B,9,b of this Section.
  3. Information designated for daily down load:
    - a. All events listed under paragraph B,9,a of this Section.
    - b. All faults listed under paragraph B,9,b of this Section.

All transmissions from the elevator control to the remote system shall have the ability to recall the remote system until information is transmitted. The number of attempts can be limited provided reasonable effort has been made. A log of attempts will be recorded and reported as part of daily down load.

All events and faults shall display date and time item took place and give description of event. It shall also list date and time item returned to normal condition.

Emergency notification shall take place only when item changes from normal condition to signal change. This information, along with date and time of restoration of that event, will be recorded on the daily report.

The elevator control shall have the capacity to store all information for a minimum of 21 days. Information collected on the eighth day shall be placed at the end of the chain while material from the first day will be deleted. This process will continue. However, material transmitted as part of the daily report shall be for the most current period from last down load transmission. Polling of information originated from the CMS shall not influence daily reporting period. Should condition be such that the daily information cannot be transmitted at the designated time, then this information will be retained and transmitted at the next scheduled time that transmission can be

made. Failure of the system to make scheduled contact shall be reported as an emergency fault.

- D. Door Operation: Open doors automatically when the car arrives at a floor to permit transfer of passengers. Automatically close doors after a timed interval.
- E. Automatic Stopping Accuracy: 2-way automatic with releveling feature stop car within 1/4" above or below the landing sill. Avoid overtravel, as well as undertravel, and maintain stopping accuracy regardless of load in car or direction of travel.
- F. Independent Service: Provide controls for operation of the elevator from car buttons only. Close doors by constant pressure on desired destination floor button. Open doors automatically upon arrival at selected floor. Any landing calls in registration shall be canceled. Landing buttons shall be made inoperative.
- G. Low-Oil Control: In the event oil level is insufficient for travel to the top floor, provide controls to return elevator to the bottom level, open doors on arrival, close doors after normal dwell time and shut down. Door will not open by activation of corridor call. Doors will open by activation of door open button in car operating panel then automatically close. Adding hydraulic fluid and recycling of mainline switch is required to return elevator to normal service.
- H. Motion Control: AC type with wye-delta reduced voltage starting and a unit type valve suitable for operation specified and capable of providing smooth, comfortable acceleration, retardation and stopping. Limit the difference in speed between full load and no load to not more than +/- 10% of the contract speed under any loading condition.
- I. Firefighters' Emergency Operation: Operate in accordance with requirements of ASME A17.1 Code.
  - Designated landing is: First Floor
  - Alternate landing is: Basement Floor
- J. Standby Lighting and Alarm: Car-mounted, battery unit with solid-state charger to operate alarm bell and lighting, per Code. Battery to be rechargeable with 5-year minimum-life expectancy. Standby lighting to be an integral with the normal lighting fixtures.
- K. Standby-Power Source: In the event normal power fails, provide controls to automatically lower the car nonstop to the lowest landing using DC battery power source installed in machine room. Include solid-state charger and testing means mounted in a common metal container. Provide rechargeable lead acid or nickel

cadmium battery 10-year minimum life expectancy. Provide switch in controller to disconnect unit during maintenance. Provide operating instructions adjacent to switch. Upon failure of normal power, lower elevator to landing, open doors automatically, hold open until regular door time has expired, then close doors and shut elevator down. Automatically resume normal operation when power is restored. Auxiliary contact in disconnect to be connected to deactivate standby power operation when switch is in "off" position.

- L. Restricted Operation: Provide an operation panel in the central command center. The panel is to include means to send the elevator to both landings, position indicator with direction arrows, two position phase 1 switch and intercom.

#### 2.4 MACHINE ROOM EQUIPMENT

- A. Arrange equipment in spaces shown in contract drawings. Provide means for removal of existing equipment and installation of new equipment in the machine room. Provide any demolition and repair made necessary by these requirements.

Provide identifying numbers on pump unit, controller and disconnect switch. Comply with N.E.C. for working clearances. Provide means and spacing to accommodate service, repair and/or replace equipment in machine room and machinery spaces.

- B. Pump Unit: New assembled unit consisting of a submersed positive-displacement pump and induction motor with accessible master-type control valves combining safety features, holding, direction, bypass, stopping and manual-lowering functions. Provide means below control valve to retain falling part and prevent entry into oil reservoir. Unit to include a shut-off valve, oil reservoir with protected-vent opening, oil gage and outlet strainer, drip pan and connections all mounted on isolating pads. Provide means to maintain oil at operating temperature.
- C. Selector: Provide a new device mounted on the car or in machine room to monitor car position and provide absolute floor position for stopping. Update parity at each floor and restore automatically after power loss.
- D. Controller: New non-proprietary control and operational system. Complete diagnostic and control/design parameter adjustments shall be accessible and shall not require the use of any special tools or devices owned or leased by control manufacturer. Equipment provided shall contain non-volatile components or software. Control manufacturer shall be available to make any required software changes. The controller shall be cabinet type, removable doors and adequate ventilation to dissipate heat. Wire to identified terminal block studs. Identifying symbols or letters identical to those on wiring diagrams permanently marked



adjacent to each component on the controller. Provide wye-delta reduced-voltage motor-starting circuits.

1. Frame: Securely mount all assemblies, power supplies, chassis switches, relays and other items on a substantial, self-supporting steel frame. Completely enclose equipment with covers and ventilate to prevent overheating.
2. Switch and Relay Design: Direct-current type, magnet operated with contacts of design and material to insure maximum conductivity, long life and reliable operation without overheating or excessive wear, and provide a wiping action to prevent sticking due to fusion. Provide switches carrying highly inductive currents with arc deflectors or suppressors.
3. Microprocessor-Related Hardware:
  - a. Fabricate printed circuit boards with FR4 or G10 glass epoxy material with a minimum equivalent 1-ounce copper.
  - b. Coat all printed circuitry with tin lead.
  - c. Include built-in noise-suppression devices which provide a high level of noise immunity on double-sided printed circuit boards.
  - d. Include built-in noise suppression devices which provide a high level of noise immunity on all solid-state hardware and devices.
  - e. Provide power supplies with noise-suppression devices.
  - f. Isolate inputs from external devices (such as pushbuttons) with opto-isolation modules.
  - g. Provide separate regulated power supply for each computer chassis.
  - h. Design control circuits so that 1 side of power supply is grounded to provide for testing.
  - i. Under no circumstances shall the safety circuits be affected by accidental grounding of any part of the system.
  - j. Design the system so that it will start properly when power is restored in the event of a power failure or interruption.
  - k. Provide system memory so that data is retained in the event of power failure or disturbance.
4. Power Supplies: UL or CSA recognized, with short-circuit protection.
5. Wiring: UL or CSA labeled copper wires for factory wiring. Neatly route all wiring interconnections and securely attach wiring connections to studs or terminals.
6. Permanently mark components (relays, fuses, PC board, etc.) with symbols shown on drawings.
7. Provide extender boards when computing devices are used inside a computer chassis to facilitate access to the printed circuit cards utilized.
8. Use stable capacitor or crystals as the time base for electronic time delay devices.

9. Provide wye-delta reduced-voltage motor-starting circuits.
- E. Muffler: Provide new muffler in discharge oil line near pump unit. Design to dampen and absorb pulsation and noise in the flow of hydraulic fluid.
- F. Piping and Oil: Provide new piping, connections and oil for the system. Use isolated couplings between the pump unit and oil lines. All piping shall be properly supported to relieve load on fittings. Piping supports shall be isolated to minimize noise and vibration.
- G. Shut-Off Valve: Manual ball type valve in line adjacent to pump unit.
- H. Noise and Vibration Control:
  1. To minimize noise and vibration in occupied areas, mechanically isolate elevator equipment from the structure; electrically isolate controllers and motor.
  2. Limit noise level relating to elevator equipment and its operation to no more than 60 dBA in elevator car under any condition including door operation and exhaust blower on highest speed.

## 2.5 HOISTWAY EQUIPMENT

- A. Guide Rails: Retain the existing.
  1. Retain existing car guide rails with supporting brackets and backing.
  2. Thoroughly clean all guide rails of grease, oil and other foreign substances, file and remove all rough edges and surfaces, align as necessary and tighten bracket bolts and guide clips for smooth and quiet operation of car.
  3. Provide any required rail backing and/or intermediate tie brackets to comply with current Code.
  4. Show guide rail loads, including the loading upon safety application, on shop drawings.
- B. Buffers: New spring type with blocking and supports.
- C. Piping: Provide new piping to extend system from machine room to jack assembly. All piping shall be properly supported to relieve load on fittings. Piping supports shall be isolated to minimize noise and vibration.
- D. Cylinder: New seamless steel pipe. Protect with Trantex VID-20 or Fiberglass wrapping sealed with epoxy resin. Design head to receive unit type packing and provide means to collect oil at cylinder head and return to oil reservoir.

- E. Plunger: New polished seamless steel tubing or pipe. If plunger length exceeds 24', provide 2 or more sections not exceeding 16' in length, or coordinate installation of longer unit at the job site. Join section by internal threaded couplings. Factory polish multiple section jack units while assembled and mark for proper future reassembly. Isolate plunger from car sling.
- F. Oil Scavenger System: Provide new means to collect oil from cylinder and automatically return filtered oil to reservoir when quantity reaches prescribed amount. The collection unit shall have a device that will prevent return of collected oil should pit be exposed to amount of water sufficient to contaminate the retained oil.
- G. Well Hole and Casing: Remove existing jack assembly. Remove and properly dispose of all debris and fill from hole. Opening in pit floor to be done such to insure water proofing of area. Install secondary Schedule 40 PVC pipe inner casing with bottom and joints sealed inside steel casing. Sealing to be done with adhesive that does not produce flammable fumes, PVC casing to extend 6 inches above plane of pit floor. Casing to be tested to assure seal and ventilated, prior to installation, to assure dissipation of flammable fumes. It is to be installed plumb. Fill space around outside of PVC casing with loose, clean sand while maintaining plumb position. Install wrapped jack unit inside PVC casing. It is to be installed plumb. Seal space between PVC casing and pit floor to maintain pit waterproofing. Close area between PVC casing and jack unit such to prevent entry of debris and liquids, but removable for inspection. In lieu of providing secondary PVC casing a Cylinder/PVC assembly can be provided. This is when the PVC casing is an integral part of the jack assembly. Design to be submitted for approval.
- Redrill well hole; remove and properly dispose of excess excavated material. Install steel casing, 20" minimum diameter and 1/4" minimum wall thickness. Casing to include waterproofing collar. Opening in pit floor to be done such to insure waterproofing of area. Close bottom of casing with at least 6" of nonshrink concrete. Install secondary Schedule 40 PVC pipe inner casing inside steel casing. PVC casing is to be installed plumb. Fill space between steel and PVC casing with loose, clean sand while maintaining plumb position. Seal space between PVC casing, steel casing and pit floor to maintain pit waterproofing.
- H. Jack Support: Provide new full width steel channels to support jack and transmit loads to building structure.
- I. Normal and Final Terminal Stopping Devices: Install new per requirements of A17.1 Code.

- J. Electrical Wiring: All existing elevator fixed wire and traveling cable shall be removed and new wire and cable installed. Existing conduit, wire duct and fittings may be reused provided it meets current requirements of National Electrical Code.
1. Conductors and Connections: Copper throughout with individual wires coded and connections on identified studs or terminal blocks. Use no splices or similar connections in wiring except at terminal blocks, control cabinets, junction boxes, or condulets. Provide 10% spare conductors throughout. Provide 4 pairs of shielded communication wires in addition to those required to connect specified items. Run spare wires from car connection points to individual elevator controllers in the machine room. Tag spares so they can be identified in the machine room.
  2. Conduit, Etc.: Painted or galvanized steel conduit, electrical metallic tubing and/or duct. Conduit size, 1/2 " minimum. Do not use flexible conduit exceeding 36" in length. Flexible heavy-duty service cord may be used between fixed car wiring and car door switches for door protective devices. Buried conduit and fittings to be galvanized steel.
  3. Traveling Cables: Flame and moisture-resistant outer cover. Include 4 sets of shielded communication wires and car lighting circuit from machine room to car connecting points. Prevent traveling cables from rubbing or chafing against hoistway or elevator equipment within hoistway.
- K. Entrance Equipment:
1. Door Hangers: 2-point suspension with upthrust adjustment. Tire rollers so that no metal-to-metal contact exists.
  2. Door Tracks: Bar or formed, convexed guiding surface, cold-drawn steel with smooth hanger contact surface. Provide removable tracks or track surface for replacement.
  3. Interlocks: Provide type operable without retiring cam. Paint interlocks flat black.
  4. Closers: Sill mounted spring type door closers.
  5. Access: Means to open doors manually from lobby side at all floors when interlock is in locked position. Provide escutcheon sleeve through door panel with fastening means to prevent removal.
- L. Pit Stop Switch: Install new per requirements of A17.1 Code.
- M. Floor Numbers: Stencil painted 4" high floor numbers within the hoistway per Code. Color to contrast with background for easy identification.

## 2.6 HOISTWAY ENTRANCES

- A. Existing hoistway entrance frames and door panels to be reused.

- B. Frames: The existing frames to be retained. They shall be refinished such to match original. Permanently attach on both jambs, floor designation 2 inches high, raised 0.030 inches, 60 inches above the floor. Numerals shall be on contrasting color background. Stick-on plates are unacceptable. Finish of floor designation to match hall station faceplates.
- C. Door Panels: The existing panels shall be retained. They shall be refinished such to match original. Existing door guide assemblies to be replaced with new guides which meet original manufacturer's specifications. Provide safety retaining means which is to be a separate assembly and not part of the guide assembly.
- D. Sight Guards: Provide new 14-gage material sight guards with same material and finish as hoistway entrance door panels.
- E. Sills: Existing to be retained. They shall be cleaned, leveled, all fastenings made secure and any loose or missing grout replaced.
- F. Sill Support Means: Existing to be reused. All fastenings made secure.
- G. Fascia, Toe Guards and Hanger Covers: Existing equipment to be thoroughly cleaned and painted. All missing and damaged fascias, guards, covers or related hardware to be replaced and all fastenings secured. Verify toe guard length is in compliance with Code regulations. Replace if necessary.
- H. Struts and Headers: Existing equipment to be thoroughly cleaned and painted. All missing and damaged hardware to be replaced and all fastenings secured. Provide door open bumpers on entrances equipped with vertical struts.

## 2.7 CAR EQUIPMENT

- A. Car Frames: Existing car frames to be replaced. Frame shall be welded, formed or bolted steel channel construction. Provide balancing weights and frames as required and properly located to achieve the required true balance. Provide crosshead data tag. Stencil paint car number (4 inch high) on crosshead beam web so it can be read from landing side.
- B. Platforms: Existing car platforms to be replaced. Isolated type, constructed of steel or wood which is fireproofed on underside.
- C. Guide Shoes: Existing guides to be removed and replaced with new roller type guides using 3 or more spring loaded sound-deadening rollers per shoe.
- D. Finish Floor Covering:

1. Remove existing floor covering. Condition floor surfaces so that they are clean, smooth, firm and free from dirt or any other damaging material. Cracks wider than 1/8 inch and holes larger than 1/4 inch in diameter shall be filled. All ridges or other uneven surfaces shall be planed, scraped, or sanded smooth. Lining felt shall be applied over wood floor surfaces and seams in felt shall be butted. Adhesive shall be applied in accordance with manufacturer's recommendations.
  2. Carpet tile flooring. Color and grade to be selected by Owner. Lay carpet flush with sill and base of car.
- E. Car Sills: Existing to be removed and replaced with new. New sill to be extruded white bronze or nickel silver. Sill to extend full width of car door in it's open position.
- F. Toe Guard: Provide new metal guard in accordance with Code requirements.
- G. Car Doors, Hangers and Tracks: Existing to be removed. Provide as specified.
1. New 2 point suspension hangers with upthrust adjustment. Tired roller so that no metal-to-metal contact exists.
  2. New bar or formed, cold drawn steel tracks with smooth hanger contact surface. Provide removable tracks or tracks surface for replacement.
- H. Header: Construct of steel; shape to provide stiffening flanges.
- I. Car Door Electrical Contact: Arrange so that elevator cannot operate unless doors are closed within tolerance allowed by Code.
- J. Car Door Clutches: Existing clutch mechanism to be replaced with new heavy-duty clutches, linkage arms, drive blocks and pickup rollers or cams to provide positive, smooth, quiet door operation. Design clutches so car doors can be closed for maintenance purposes, while hoistway doors remain open. Clutch shall include means to restrain car doors from opening more than 4 inches when the elevator is outside the unlocking zone.
- K. Door Operator and Operation: New medium-speed, heavy-duty, master door operator capable of opening doors at no less than 1-1/2 f.p.s., and accomplishing reversal in no more than 2-1/2" of door movement. Open doors automatically when car arrives at a floor to permit egress of passengers. Close doors automatically after a timed interval.
- L. Door Reopening and Control Devices: Existing door protection to be removed and replaced with new.



1. Infrared Detector Device:
  - a. New multi-beam infrared pulsed screen car door protective device projecting across entire entrance opening. If the device becomes inoperative, the door closing kinetic energy shall immediately be reduced to a maximum of 2 1/2 foot pounds and a buzzer will sound during each closing operation.
  - b. Interrupted Screen Time: If screen is interrupted after doors are open, reduce time doors normally remain fully open to an adjustable time of about one second after screen is reestablished.
2. Forced Door Closing: If door opening is obstructed for a predetermined adjustable time (15 - 45 seconds), with initial setting at **30 seconds**, sound buzzer and attempt to close doors with a maximum of 2 1/2 foot pounds kinetic energy.
3. Differential Door Time: Provide separately adjustable timers to enable varying time that doors remain open after stopping in response to calls.
  - a. Car Call: Hold open time with adjustable range of 0 to 10 seconds. Initial setting to be **3 seconds**.
  - b. Landing Call: Hold open time with adjustable range of 0 to 15 seconds. Initial setting to be **6 seconds**. Use landing call timing when responding to coincidental calls.

M. Elevator Car Operating Panel:

1. New elevator control station with faceplate and a metal box containing the operating fixtures, mounted behind the car enclosure stationary front return panel.
2. Locate operating controls no higher than 48" above the car floor; 35" for alarm button. Suitably identify floor buttons, alarm button and door open and close button by flush type raised letters or symbols against a contrasting color background per Local Accessibility Standards including braille.
3. Provide 1/8" raised brushed bronze type floor pushbuttons with illuminating halo around the perimeter of the button to indicate call registration. (Example Innovation PB-29)
4. Provide illuminated alarm button at bottom of station to ring bell. Button to illuminate as bell sounds.
5. Provide keyed stop switch in panel faceplate with markings to show "run" and "stop" positions, or locate similarly identified button or switch in locked service cabinet.

6. Provide door open and door close buttons to stop and reopen closing doors and activate door closing. Make buttons operable while car is stopped at landing, regardless of special operational features (except Firefighters' Service).
7. Provide Phase I Emergency Recall Operation visual and audible signals as required by Code.
8. Provide Firefighters' service key switch with engraved instructions, stop switch, door open and closed buttons, light, and call cancel button per Code requirements.
9. Provide lockable service panel with recessed, flush cover plate matching main panel. Include the following controls with purpose and operating positions identified by engraved letters painted black:
  - a. Inspection switch, conforming to the Code, for disconnecting automatic operation, limiting the car speed and activating hoistway access switches when car is at access landing. Switch to be keyed same as access switches.
  - b. Light switch.
  - c. 3-position exhaust blower switch.
  - d. Independent service switch to permit selection of independent or automatic operation.
  - e. Duplex 120-volt, AC, electrical convenience outlet GFCI type.
10. Provide black paint filled engraving with size and style as required by respective Code or as approved. Engraving to be as follows:
  - a. Elevator number on main car station
  - b. Elevator capacity in pounds on main car station
  - c. Firefighters' Instructions
  - d. Emergency Communication Instructions
  - e. Warning sign to read "WARNING - ELEVATORS SHALL NOT BE USED IN EVENT OF FIRE. USE MARKED EXIT STAIRWAYS". Lettering for "WARNING" shall be at least 3/8 inch high. Remainder of lettering shall be at least 1/4 inch high.
11. Faceplate Material and Finish: Bronze with No. 4 brushed finish. All edges shall be beveled. Faceplate to be sized to cover opening in return panel and to cover any damage resulting from installation.
12. Montgomery County Standard barrel type key codes:
  - a. Firefighters' Service FEO-K1
  - b. Inspection and Hoistway Access 514
  - c. In-car Stop Switch 514
  - d. Light 513
  - e. Fan 513

|                        |     |
|------------------------|-----|
| f. Independent Service | 513 |
| g. Service Cabinet     | 513 |
| h. Communication Reset | 511 |

- N. Car Top Control Station: Existing to be removed and replaced with new station per requirements of A17.1 Code. Device shall be permanently attached to crosshead.
- O. Emergency Exit: Provide new contact on exit which when open prevents operation of elevator.
- P. Work Light and Duplex Plug Receptacle: Top and bottom of elevator car. GFCI type outlets. Provide lights with on-off switch and bulb guard.
- Q. Communication System:
1. Provide a new self-dialing (hands-free) communication system incorporated in the car operating panel. New speaker-transmitter shall be compatible with existing building communication system. Perforations for the speaker-transmitter shall be provided in the cover of car operating panel. Perforations sized and protected to prevent vandalism damage to device behind. Activation of the call annunciation shall be through a "PHONE" pushbutton. A telephone symbol shall appear adjacent to the "PHONE" pushbutton which is a button similar to car operating buttons. Pressing of the button shall cause the automatic placement of a call to a point of 24-hour monitoring. The call button shall illuminate to indicate the call is being made. Communicating through the instrument shall be done without any further depression of the activation button. A visual indicator in the car panel shall light once the call has been received. Instructions under the visual indicator shall read as follows: "Assistance is on the Way". The devices shall also be capable of receiving incoming calls.
  2. Furnish and install all traveling cable, conductors, conduits, etc., required for the service from the cabinet in the car to the connection box in the machine room.
  3. Emergency procedure instructions shall read as follows: "TO USE EMERGENCY COMMUNICATION, PRESS THE "PHONE" BUTTON. SIGNALING WILL OCCUR AUTOMATICALLY".

## 2.8 CAR ENCLOSURE

- A. Existing car enclosure to be removed and replaced with new enclosure. New enclosure design shall be submitted for approval.
- B. Shell: Nonperforated reinforced 14-gage furniture steel with Bronze satin finish reveals around interior panels. Apply sound-deadening mastic to exterior.

- C. Top: Reinforced 12-gage furniture steel with hinged exit openable from car top only. Provide contact on exit which when open prevents operation of elevator. Finish with white, reflective enamel.
- D. Front Return Panels: 14-gage bronze with satin finish. Provide cutouts for car stations, etc.
- E. Entrance Columns: 14-gage bronze with satin finish.
- F. Transom: 14-gage bronze with satin finish and cutouts for car position indicator.
- G. Car Door Panels: 16-gage steel, sandwich construction without binder angles. Provide a minimum of 2 door guide assemblies per door panel, one guide at leading and one at trailing edge with guides in the sill groove their entire length of travel. Interior face to be brushed bronze with satin finish.
- H. Base: Cove type 14-gage bronze with satin finish and concealed ventilation cutouts.
- I. Interior: Two equally sized wood panels on each side and three equally sized panels across the back. Panels to be faced with plastic laminate. Edges shall be covered with 1/8 inch satin finish bronze framing. Interior edge of framing shall project 1/16 inch beyond panel facing and have edges rounded. Other edge will wrap behind wood panel such to conceal mounting. No fastenings will be visible. All corners will be mitered. Reveals between and around the panels shall be satin finish bronze. The color and finish for plastic laminate to be selected by Owner
- J. Flooring: See paragraph 2.7,D of this Section.
- K. Ventilation: 3-speed exhaust blower mounted on isolated rubber grommets, Morrison Products, Model AA with a diffusor and grille.
- L. Island type suspended ceiling using 3/4 inch wood core with bronze satin finish on interior and exposed edges
- M. Lighting: Provide 6 round LED down lights. Lighting to be evenly spaced. Provide wiring and hookup for lighting system.
- N. Handrails: 2 inch x 3/8 inch flat brushed bronze bars with satin finish on two sides and back located 34 inches from floor to centerline. Fastenings shall be vandal proof and reinforced to prevent damage to enclosure.

2.9 LANDING CONTROL STATIONS: Provide new

- A. Pushbuttons: Existing pushbutton stations to be removed. A new riser of flush mounted stations as shown on drawings to be provided. Provide only a key switch with illuminated signal to register a call. Centerline of call buttons to be 42 inches above lobby floor. Each station shall include an engraved warning sign as specified in paragraph 2.7,M,10,e of this Section in pushbutton faceplate and fill with black. Designated landing station to include Firefighters' Service controls with engraved instructions. All engraving shall be filled with black unless otherwise noted. Faceplate to be sized to cover area of existing station and any damage resulting from installation of new station. Faceplate layout to be such to compliment size of plate.
- B. Hoistway Access Switches: Mount in the strike jamb recess of the hoistway entrance at bottom and top floor. They shall be positioned at a height of 6 feet above finished floor. Switch shall be identified and designated position relating to direction of travel should also be identified. No faceplate shall be used.
- C. Faceplate Material and Finish: Bronze with satin finish. All edges shall be beveled.
- D. Faceplate Size: New panels shall be sized to encompass area of existing panel and any defacement of the surrounding surface. When wall surface is irregular means will be provided to close the gap between the faceplate and wall surface.

2.10 SIGNALS: Provide New

- A. Car Position Indicator: Provide vandal resistant digital type indicator shall be provided. It shall show the floor served and the direction of car travel. It shall be located above the car door. When a car leaves or passes a floor, illuminate numeral representing position of car in hoistway. Illuminate proper direction arrow to indicate the direction of travel. Provide audible signal which will sound when car is stopping at or passing a landing.
- B. Corridor Position Indicator: Provide vandal resistant digital-type indicator with directional arrows as shown on drawings. Characters shall be at least 3/4 inches high. When the car leaves or passes a floor, illuminate numeral representing position of car in hoistway. Illuminate proper direction arrow to indicate the direction of travel. Fixture to be vertically oriented and located adjacent to the hoistway entrance.
- C. Faceplate Material and Finish: Bronze with satin finish. All edges shall be beveled.

**PART 3 - EXECUTION**

3.1 SITE CONDITION INSPECTION

- A. Prior to beginning installation of equipment, examine hoistway and machine room areas. Verify that no irregularities exist which affect execution of work specified.
- B. Do not proceed with installation until work in place conforms to project requirements.

### 3.2 PRODUCT DELIVERY, STORAGE AND HANDLING

- A. Deliver materials in Manufacturer's original, unopened protective packaging.
- B. Store material in original protective packaging. Prevent soiling, physical damage, and wetting.
- C. Protect equipment and exposed finishes during transportation, erection, and construction against damage and stains.

### 3.3 INSTALLATIONS

- A. Install each equipment item in accordance with Manufacturer's direction, referenced codes, and specifications.
- B. Install machine room equipment with clearances in accordance with referenced codes and specifications.
- C. Install equipment with sufficient clearance such that they may be easily removed for maintenance and repair.
- D. Install equipment with sufficient clearance such that access for maintenance is safe and parts are readily available.
- E. Install equipment to afford maximum safety and continuity of operation.
- F. Clean the following items of oil, grease, scale, and other foreign matter, and apply one coat of field-applied industrial enamel paint. Surfaces not previously painted shall be given a prior coat of rust inhibiting paint.
  - 1. All exposed stationary equipment and metal work relating to elevator which does not have architectural finish.
  - 2. Machine room equipment.
  - 3. Neatly touch up damaged factory-painted surfaces with original paint and color. Protect machine-finish surfaces against corrosion.

### 3.4 FIELD QUALITY CONTROL



- A. Work at the job site will be checked during the course of installation. Contractor shall utilize periodic quality control inspections by supervisory personnel to insure quality of work and adherence to specifications.
- B. Owner and/or Enforcing Authority may conduct inspections of work.
- C. Full cooperation with reviewing personnel is mandatory. Accomplish corrective work required prior to performing further installation.

### 3.5 ADJUSTMENTS

- A. Align guide rails vertically with tolerance of 1/16 inch top to bottom. Secure joints without gaps and file any irregularities to a smooth surface.
- B. Balance cars to equalize pressure of guide rollers on rails.
- C. Lubricate all equipment in accordance with manufacturer's instructions using manufacturer's specified lubrication.
- D. Adjust pump unit, valve, controller, leveling switches, limit switches, stopping switches, door operator, interlocks and safety devices, etc., in accordance with manufacturer's instructions to achieve required performance levels.
- E. Fabricate and assemble various parts in shop to minimize field assembly. Assemble parts, in the shop which require close field fit and mark for field erection.

### 3.6 CLEANUP

- A. Keep work areas orderly and free from debris during progress of project. Remove packaging materials on a daily basis as equipment is installed.
- B. Remove daily all loose materials and filings resulting from work.
- C. Clean machine room equipment and floor of dirt, oil and grease.
- D. Clean hoistways, cars, car enclosures, entrances, operating and signal fixtures, and trim of dirt, oil, grease, and fingermarks.

### 3.7 PAINTING AND FINISHES

- A. All equipment and metal work installed or reused under this contract, which does not have a baked enamel or special architectural finish and which is exposed in the hoistway, shall be cleaned and painted one field coat of enamel. The shank and base

of the T-Section of the guide rails shall be thoroughly cleaned and painted one field coat of black metal enamel.

- B. All machine room equipment shall be painted upon completion of the installation with the manufacturer's standard machinery enamel.
- C. All natural metals shall be of the best grade and shall have the grain of belting in the direction of the longest dimension with a fine, brushed finish. All surfaces shall be perfectly smooth and without waves.
- D. All building surfaces damaged as a result of work done shall be refinished to match existing conditions. Color and texture shall match adjacent areas. Contractor shall employ the services of personnel specially trained and experienced in the finishing of the respective surfaces. The areas requiring to be refinished shall be determined based on ability of Contractor to provide acceptable blend into existing finished surface.

### 3.8 ACCEPTANCE INSPECTION AND TESTS

- A. General: Furnish labor, materials and equipment necessary to perform all inspections and testing.
- B. Code Required Acceptance Inspection and Testing: Contractor is responsible to have Code Authority to perform required inspections and testing. Contractor shall notify the Owner of schedule date at least 5 days in advance. This inspection and test will not be scheduled unless Contractor has performed acceptable quality control inspection and tests prior. Verification of such quality control inspection and test shall be submitted to the Owner prior to scheduling.
- C. Owner's Acceptance Inspection and Tests: Owner's acceptance of installation shall be made only after Code Authority has completed their inspection and all identified deficiencies have been corrected, accepted and copies of inspection reports provided for the Owner's file. The inspections and tests shall include, but not limited to, the following:
  - 1. Workmanship and equipment comply with drawings and specifications.
  - 2. Contract speed, capacity and floor-to-floor performance comply with specification.
  - 3. Performance of following are satisfactory:
    - a. Starting, accelerating, running
    - b. Decelerating, stopping accuracy
    - c. Door operation, closing force and associated operational function
    - d. Equipment noise levels

- e. Signal fixture utility
- f. Overall ride quality
- g. Overall performance of operational system
- h. Ability of on-site monitoring to perform
- i. Ability of remote monitoring to interface with existing Central Monitoring System.

4. Test Results:

- a. In all test conditions, obtain specified speed, performance times, floor accuracy without releveling and ride quality to satisfaction of the Owner.
- b. Temperature rise in windings limited to 50 degrees Celsius above ambient. Conduct a verification full-capacity, one-hour running test, stopping at each floor for 10 seconds in up and down directions.

D. Performance Guarantee: Should inspections and tests reveal defects, poor workmanship, variance or noncompliance with requirements of specified Codes and/or ordinances, or variance or noncompliance with the requirements of specifications, complete corrective work to satisfaction of the Owner at no additional cost:

- 1. Replace equipment that does not meet Code or specification requirements.
- 2. Perform work and furnish labor, materials and equipment necessary to meet specified operation and performance.
- 3. Perform and assume cost for retesting required by Governing Code Authority and the Owner to verify specified operation and/or performance.

3.9 ACCEPTANCE OF DOCUMENTS: Contractor provides complete and proper documentation as required elsewhere in this Section.

END OF SECTION 142400

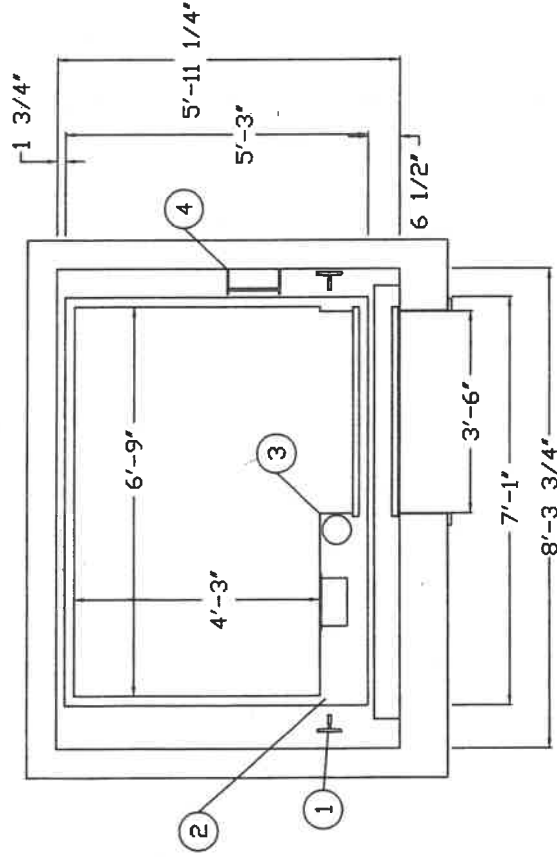

1. REMOVE EXISTING GUIDE RAILS.
2. REMOVE EXISTING GUIDES.
3. REMOVE EXISTING CAB ENCLOSURE.
4. REMOVE EXISTING PIT ACCESS LADDER.

EXISTING HOISTWAY PLAN  
 SCALE = NTS 1383-A  
 JANUARY 2020

STRATHMORE MANSION  
 MONTGOMERY COUNTY, ROCKVILLE

ROBERT L. SEYMOUR & ASSOCIATES, INC.  
 Vertical Transportation Consultants  
 182 THOMAS JOHNSON DRIVE SUITE 200  
 FREDERICK, MD 21702  
 301-662-8112



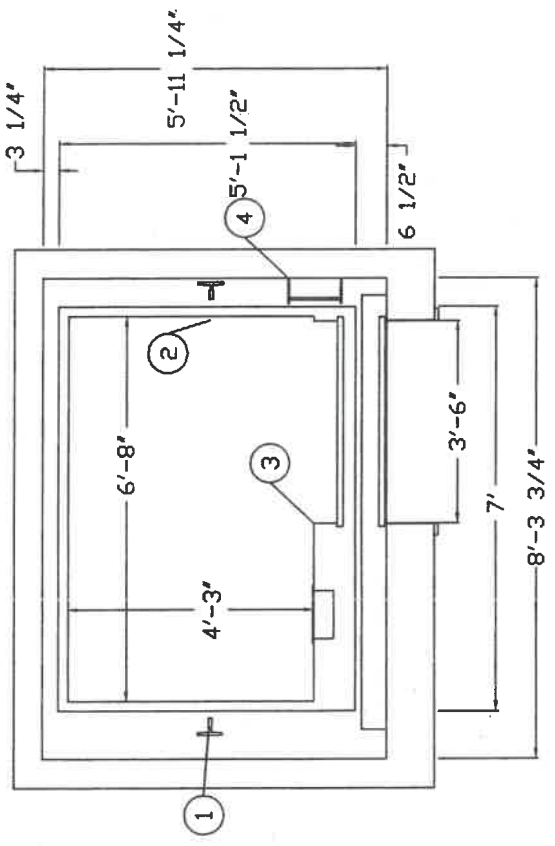

1. PROVIDE GUIDE RAILS.
2. PROVIDE ROLLER GUIDES.
3. PROVIDE CAB ENCLOSURE.
4. PROVIDE PIT ACCESS LADDER.

ROBERT L. SEYMOUR & ASSOCIATES, INC.  
 Vertical Transportation Consultants  
 182 THOMAS JOHNSON DRIVE SUITE 200  
 FREDERICK, MD 21702  
 301-662-8112

STRATHMORE MANSION  
 MONTGOMERY COUNTY, ROCKVILLE

NEW HOISTWAY PLAN  
 SCALE = NTS  
 JANUARY 2020  
 1383-A1

1. REMOVE EXISTING PUMP UNIT & PIPING.
2. REMOVE EXISTING CONTROLLER & STARTER.
3. REMOVE EXISTING MAINLINE DISCONNECTS.
4. REMOVE EXISTING 120 VOLT DISCONNECTS.

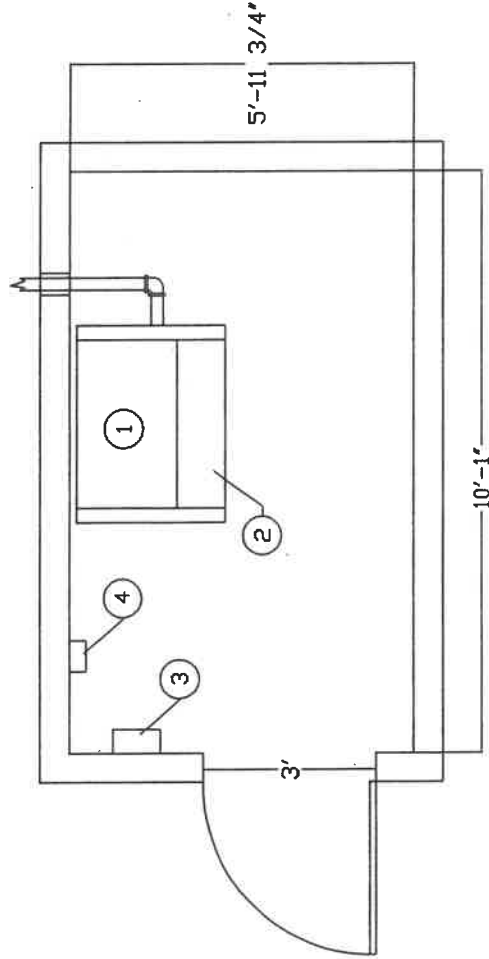

ROBERT L. SEYMOUR & ASSOCIATES, INC.  
 Vertical Transportation Consultants

182 THOMAS JOHNSON DRIVE SUITE 200  
 FREDERICK, MD 21702  
 301-662-8112

EXISTING MACHINE ROOM PLAN

SCALE = NTS  
 JANUARY 2020

1383-B

STRATHMORE MANSION  
 MONTGOMERY COUNTY, ROCKVILLE



1. PROVIDE PUMP UNIT & PIPING.
2. PROVIDE CONTROLLER.
3. PROVIDE MAINLINE DISCONNECT.
4. PROVIDE 120 VOLT DISCONNECT.

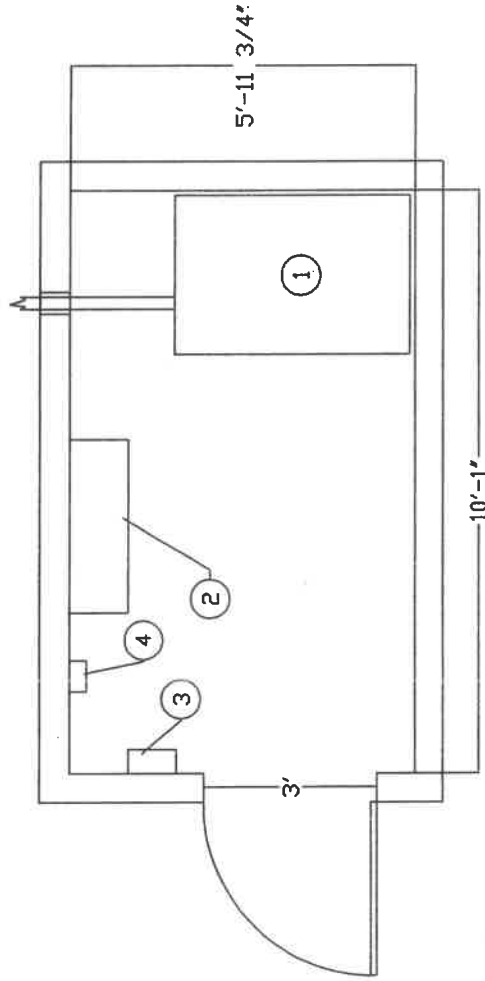

ROBERT L. SEYMOUR & ASSOCIATES, INC.  
 Vertical Transportation Consultants  
 182 THOMAS JOHNSON DRIVE SUITE 200  
 FREDERICK, MD 21702  
 301-662-8112

NEW MACHINE ROOM PLAN

SCALE = NTS

JANUARY 2020

1383-B1

STRATHMORE MANSION  
 MONTGOMERY COUNTY, ROCKVILLE



**ROBERT L. SEYMOUR & ASSOCIATES, INC.**  
Vertical Transportation Consultants  
182 THOMAS JOHNSON DRIVE SUITE 200  
FREDERICK, MD 21702  
301-862-8112

STRATHMORE MANSION  
MONTGOMERY COUNTY, ROCKVILLE

EXISTING HOISTWAY ELEVATION  
SCALE = NTS  
JANUARY 2020  
1383-C

1. REMOVE EXISTING CAR SLING & PLATFORM.
2. REMOVE EXISTING CAR ENCLOSURE.
3. REMOVE EXISTING CAR DOOR OPERATOR.
4. REMOVE EXISTING HOISTWAY DOOR HARDWARE.
5. REMOVE EXISTING JACK ASSEMBLY.

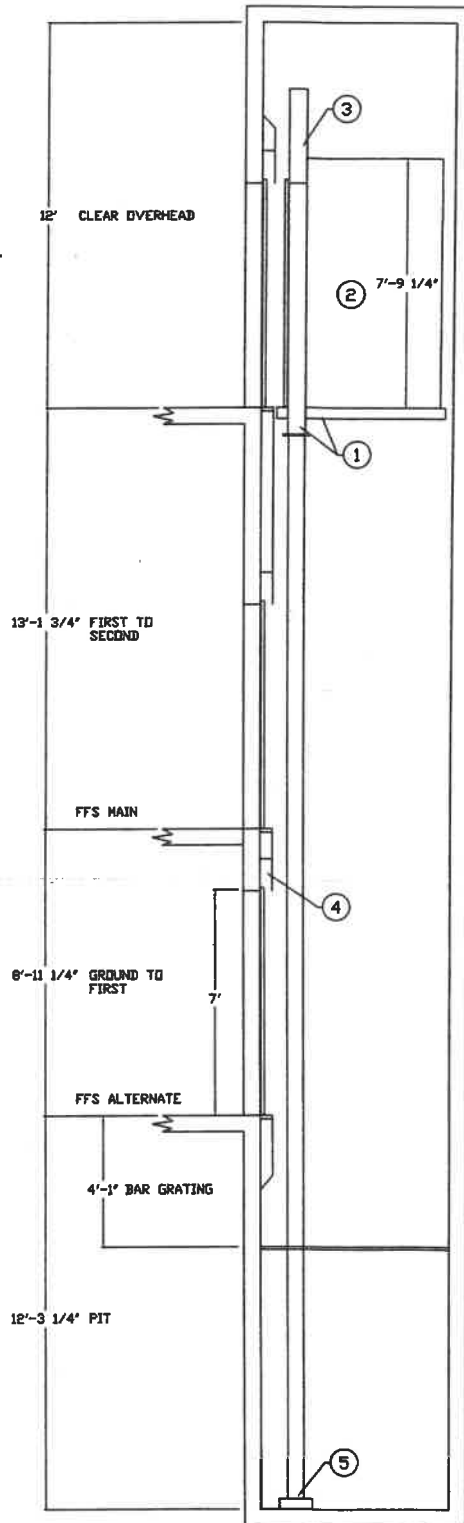



**ROBERT L. SEYMOUR & ASSOCIATES, INC.**  
 Vertical Transportation Consultants  
 182 THOMAS JOHNSON DRIVE, SUITE 200  
 FREDERICK, MD. 21702  
 501-682-8112

STRATHMORE MANSION  
 MONTGOMERY COUNTY, ROCKVILLE

NEW HOISTWAY ELEVATION  
 SCALE = NTS  
 JANUARY 2020  
 1383-C1

1. PROVIDE CAR SLING & PLATFORM.
2. PROVIDE CAR ENCLOSURE.
3. PROVIDE CAR DOOR OPERATOR.
4. PROVIDE HOISTWAY DOOR HARDWARE.
5. PROVIDE JACK ASSEMBLY.
6. PROVIDE NEW BAR GRATING.

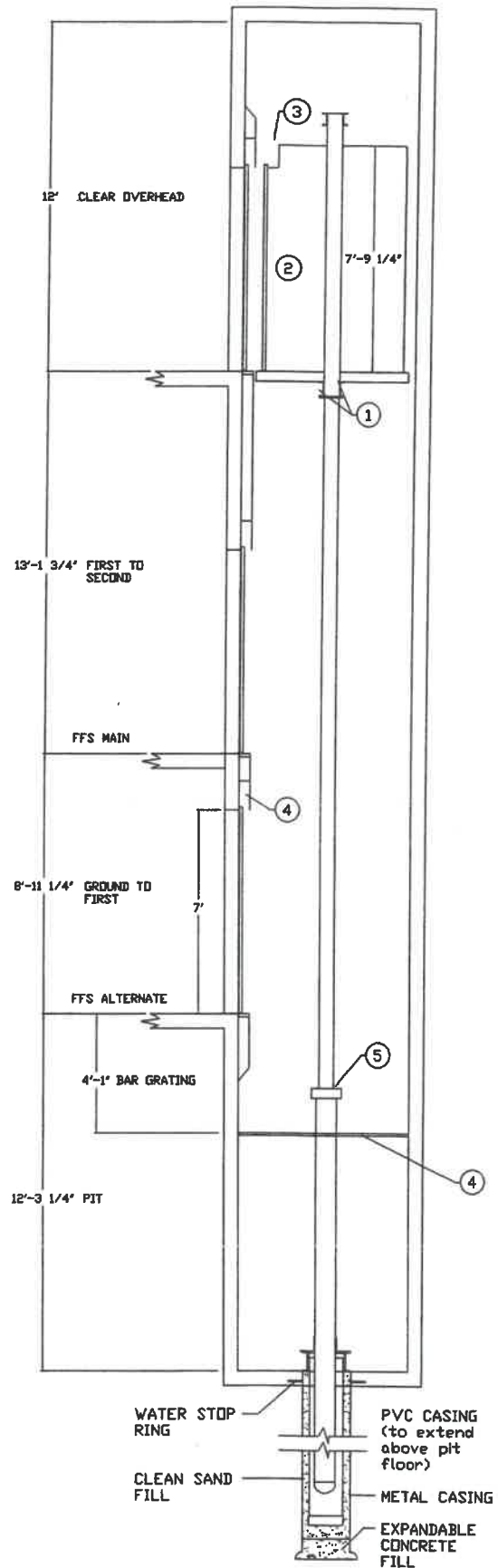

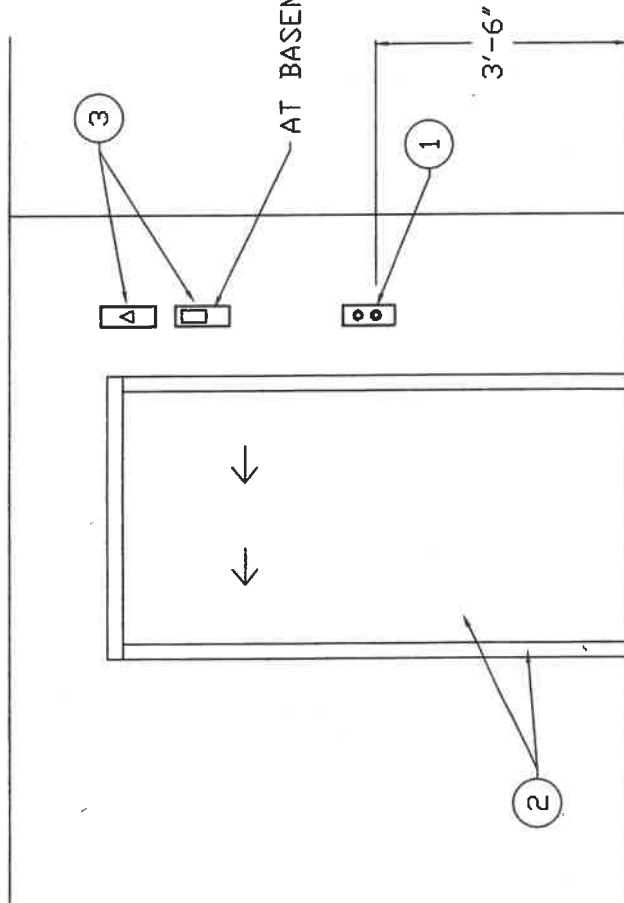

1. REMOVE EXISTING CORRIDOR PUSHBUTTON STATION AND PATCH WALL.
2. REFURBISH EXISTING HOISTWAY DOOR PANELS & DOOR FRAMES.
3. REMOVE EXISTING HALL LANTERN AND KEY BOX. PATCH WALL.

AT BASEMENT LEVEL

3'-6"

**ROBERT L. SEYMOUR & ASSOCIATES, INC.**  
 Verified Transportation Consultants  
 182 THOMAS JOHNSON DRIVE SUITE 200  
 FREDERICK, MD 21702  
 301-662-8112



**STRATHMORE MANSION**  
 MONTGOMERY COUNTY, ROCKVILLE

EXISTING LANDING, ELEVATION

SCALE = NTS  
 JANUARY 2020

1383-D

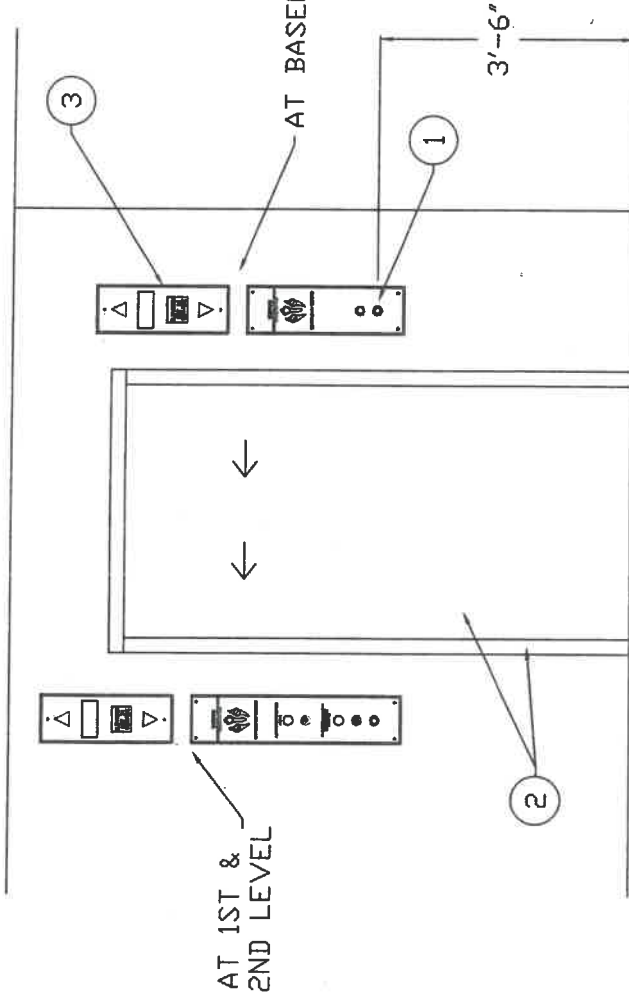

1. PROVIDE CORRIDOR PUSHBUTTON STATION.
2. REFURBISH EXISTING HOISTWAY DOOR PANELS & DOOR FRAMES.
3. PROVIDE COMBINATION POSITION INDICATOR AND HALL LANTERN WITH "OUT OF SERVICE" LIGHT.

 **ROBERT L. SEYMOUR & ASSOCIATES, INC.**  
 Vertical Transportation Consultants  
 182 THOMAS JOHNSON DRIVE SUITE 200  
 FREDERICK, MD 21702  
 301-662-8112

**STRATHMORE MANSION**  
 MONTGOMERY COUNTY, ROCKVILLE

**NEW LANDING ELEVATION**  
 SCALE = NTS  
 JANUARY 2020  
 1383-D1





