

Super Simplex Disappearing Stairway

Division
11 33 00

Super Simplex
Disappearing
Stairway

Available With 2 Hour Fire Rating
Ceiling Heights Up To 13'6"

MEETS A.N.S.I.
A14.9-2019



Precision Stairways • P.O. Box 2279 • Morristown, TN 37816
Phone: (800) 225-7814 or (423) 586-2265 • Fax: (423) 586-2091
email: info@precisionstairways.com • www.precisionstairways.com

Precision
Stairways

www.PrecisionStairways.com



Super Simplex Disappearing Stairway

Super Simplex Disappearing Stairway

Precision offers customized construction for any job. Compare these features to the competition:

- Meets requirements of A.N.S.I. A14.9-2010 for "Commercial" or "Residential" use
- Test Weight of 500 lbs
- Individual tread test weights of 1000 lbs
- Actual shear of rivets tested to 1175 lbs
- Steel frame
- Extruded aluminum treads & siderails
- 5 3/16" x 18" (std) clear tread area
- Clear tread width varies depending on frame width (22 1/2" min - 39" max)

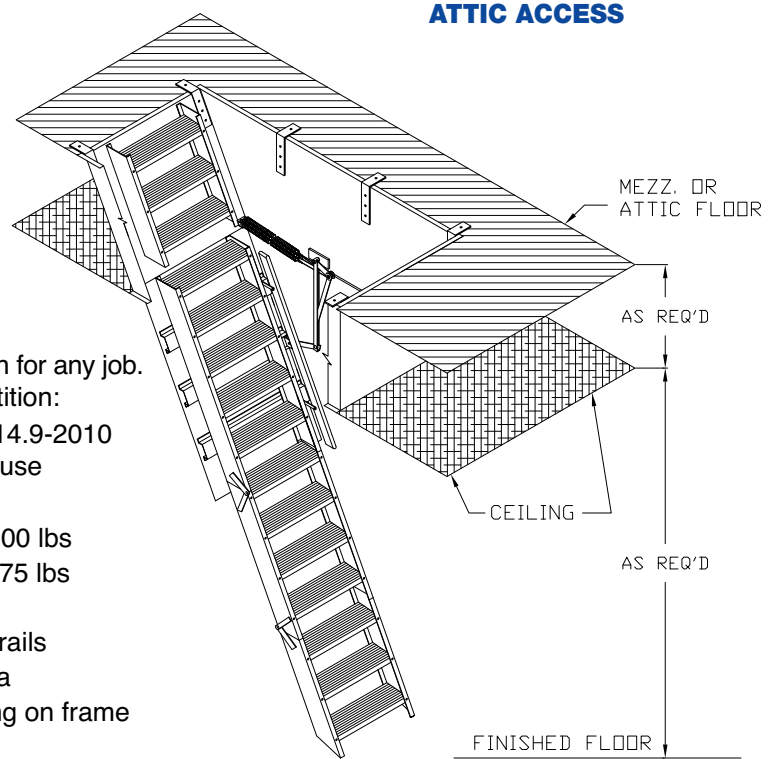

OPTIONS

- Lock on door panel (std on fire-rated unit)
- Special deep frame to accommodate dropped ceilings
- Recessed door panel for installation of ceiling finishes (on non-rated units only)
- Factory mounted roof hatch to utilize unit for roof access
- 2 hour fire-rated Warnock Hersey label that meets ASTM E-119 & UBC 43-7 requirements, passed 250° temperature rise in the first 30 minutes.
- Precision Fold-Assist (std on units 9-10" and taller.)

Note: Best to install fire-rated units before drywalling ceiling

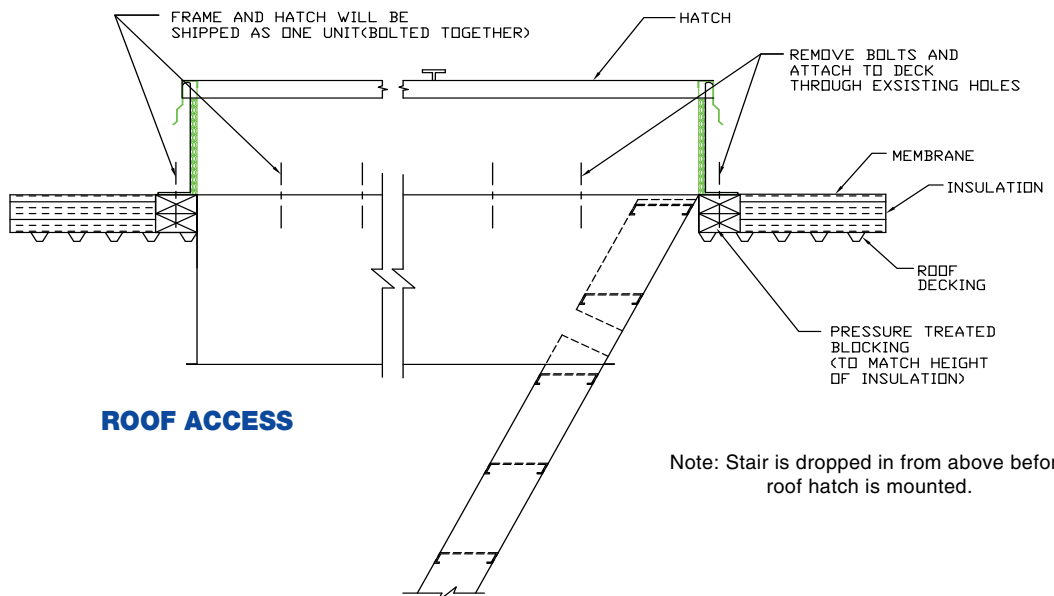

Note: Stair is dropped in from above before roof hatch is mounted.

Precision
Stairways
www.PrecisionStairways.com



**Super Simplex
Disappearing
Stairway**

Use the drawings at right with the charts below to find the dimensions for stairway.

Required Information:

1. Floor to ceiling height ("C")
2. Distance from finished ceiling to floor above ("D")

If "D" is less than 12", the std box frame will work fine, only Chart 1 is needed.

If "D" is 12" or more, Chart 2 is needed to determine the opening size at the floor above.

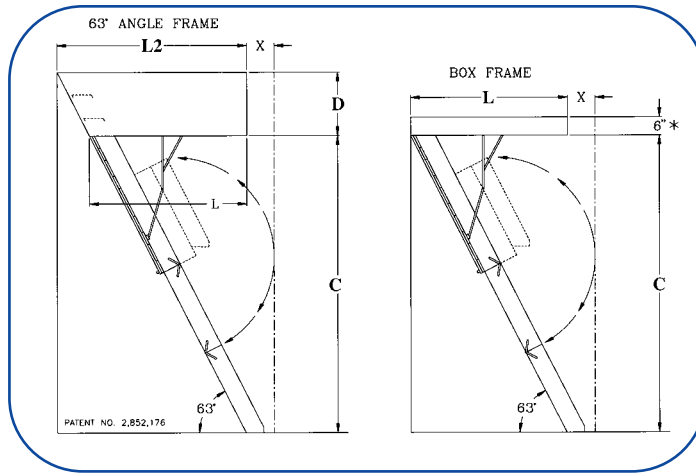

For additional "D's" on Chart 2, please call the factory.

CHART 1

C (CEILING HEIGHT)	X (CLEARANCE)	L	Rough Opening in ceiling	Rough Opening in floor above*
7' 1" to 8' 0"	13"	53 1/4"	30" x 54"	30" x L2 + 3/4"
8' 1" to 8' 9"	14 1/2"	53 1/4"	30" x 54"	30" x L2 + 3/4"
8' 10" to 9' 9"	22"	53 1/4"	30" x 54"	30" x L2 + 3/4"
9' 10" to 10' 11"	18"	63 1/4"	30" x 64"	30" x L2 + 3/4"
11' 0" to 12' 0"	26"	63 1/4"	30" x 64"	30" x L2 + 3/4"
12' 1" to 13' 6"	26"	71 1/4"	22 1/2" x 72"	22 1/2" x L2 + 3/4"

* If std box frame is used, this dimension is the same as the ceiling opening.
If 63° angle frame is used, see chart at right to determine "L2"

See Website for Rough Opening and Footprint Calculators

CHART 2

D	L2	D	L2
12"	L + 6 1/8"	31"	L + 15 13/16"
13"	L + 6 5/8"	32"	L + 16 5/16"
14"	L + 7 1/8"	33"	L + 16 13/16"
15"	L + 7 5/8"	34"	L + 17 5/16"
16"	L + 8 1/8"	35"	L + 17 13/16"
17"	L + 8 11/16"	36"	L + 18 5/16"
18"	L + 9 3/16"	37"	L + 18 7/8"
19"	L + 9 11/16"	38"	L + 19 3/8"
20"	L + 10 3/16"	39"	L + 19 7/8"
21"	L + 10 11/16"	40"	L + 20 3/8"
22"	L + 11 3/16"	41"	L + 20 7/8"
23"	L + 11 3/4"	42"	L + 21 3/8"
24"	L + 12 1/4"	43"	L + 21 15/16"
25"	L + 12 3/4"	44"	L + 22 7/16"
26"	L + 13 1/4"	45"	L + 22 15/16"
27"	L + 13 3/4"	46"	L + 23 7/16"
28"	L + 14 1/4"	47"	L + 23 15/16"
29"	L + 14 3/4"	48"	L + 24 7/16"
30"	L + 15 5/16"		

Product Details

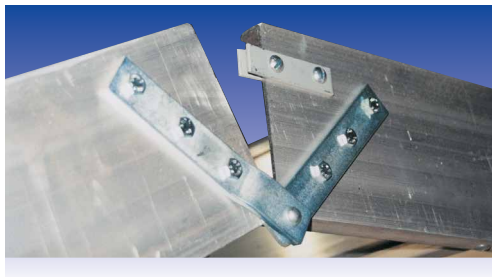

Side Rail Hinge



Heavy Duty Tread



Adjustable Foot



Fold - Assist



Cable and Spring

**Precision
Stairways**
www.PrecisionStairways.com



Super Simplex Disappearing Stairway

Precision
Stairways
www.PrecisionStairways.com

SECTION 11 33 00 RETRACTABLE STAIRS

PART 1: GENERAL

1.1 SECTION INCLUDES

- A. Manual disappearing stairways.

1.2 REFERENCES

- A. ANSI A14.9: Safety Requirements for Ceiling Mounted Disappearing Climbing Systems.

1.3 SUBMITTALS

- A. Submit under provisions of Section 01300.
- B. Manufacturer's data sheets on each product to be used, including:
 - 1. Preparation instructions & recommendations.
 - 2. Storage and handling requirements & recommendations.
 - 3. Installation methods.
- C. Shop Drawings for Stairs:
 - 1. Plan and section of stair installation.
 - 2. Indicate rough opening dimensions for ceiling and/or roof openings.

1.4 DELIVERY, STORAGE, AND HANDLING

- A. Store stairway until installation inside under cover in manufacturer's unopened packaging. If stored outside, under a tarp or suitable cover.

1.5 WARRANTY

- A. Limited Warranty: One year against defective material and workmanship, covering parts only. Defective parts, as deemed by the manufacturer, will be replaced at no charge, freight excluded, upon inspection at manufacturer's plant.

PART 2 PRODUCTS

2.1 MANUFACTURERS

- A. Acceptable Manufacturer:
Precision Stairways
P.O. Box 2279; Morristown, TN 37816-2279;
Tel: 423-586-2265; Fax: 423-586-2091;
www.PrecisionStairways.com
- B. Requests for substitutions will be considered in accordance with provisions of Section 01600.

2.2 MANUAL DISAPPEARING STAIRWAY.

- A. Standard Model: Super Simplex Disappearing Stairway as manufactured by Precision Stairways. Stairs for ceiling heights 7'-0" – 12'-0": Model 1000 (ceiling height in inches). Stairs for ceiling heights 12'-1" – 13'-6": Model 2000 (ceiling height in inches).
- B. Performance Standard: Unit shall comply with ANSI A14.9, Commercial Type, for rough openings between 27 inches to 39 inches. Residential Type for rough openings between 22-1/2 inches to 27 inches. Stairway capacity shall be rated at 500 lbs.
- C. Accessories:
 - 1. Steel pole to aid opening and closing stairways.
 - 2. Stairs for ceiling heights 9' -10" – 12' -0" shall be equipped with a patented Precision Fold Assist to aid in folding and unfolding of sections. Stairs for ceiling heights 12' 1" – 13'6" shall be equipped with 2 Fold Assists. Precision Fold-Assist is optional on stairways for ceiling heights of 9' 9" and below.
 - 3. Keyed lock for door (standard on fire-rated models, optional on non-fire-rated models).

D. Components:

- a. Ceiling height of 9' 9" or less requires opening of 30" x 54"
- b. Ceiling heights 9' 10"–12' 0" require opening of 30" x 64"

Specifications

- c. Ceiling heights 12' 1"–13' 6" require opening of 22½" x 72"
- 2. Stairway Stringer: 6005-T5 Extruded aluminum channel 5" x 1" x 1/8"; tri-fold design; steel blade type hinges; adjustable feet with plastic Mar-guard. Pitch shall be 63°.
- 3. Stairway Tread: 6005-T5 extruded aluminum channel 5 3/16 inches by 1 1/4 inches by 1/8 inch. Depth is 5 3/16 inches. Deeply serrated top surface. Riser Height: 9-1/2 inches. Clear Tread Width for Standard Width: 18 inches.
- 4. Railing: Aluminum bar handrail riveted to stringers, upper section only.
- 5. Frame:
 - a. If ceiling to floor (or roof deck) above is under 12", frame shall be 1/8" steel formed channel, box.
 - b. When ceiling to floor (or roof deck) above is 12" or greater, the frame shall be 1/8" steel, 63° (with built-in steps) on the hinge end, 90° on the other end, custom depth to fill distance from ceiling to floor above. This custom frame will require a longer opening in the floor above than is required at the ceiling level.
- 6. Door Panel
 - a. Standard (non-fire rated) door shall be constructed of 1/8 inch (3 mm) aluminum sheet attached to stairway frame with a steel piano hinge. Door overlaps bottom flange of frame. Eye bolt accommodates pole for opening and closing door.
 - b. On fire-rated models, the door panel shall be constructed of 20 gauge steel and have a 2 hour fire rating for use in fire-rated ceiling assemblies as issued by Warnock-Hersey or other appropriate independent testing / licensing agency.
- 7. Hardware:
 - a. Steel blade type hinge connecting stringer sections. Zinc plated and clear trivalent chromate sealed.
 - b. Steel operating arms, both sides. Zinc plated and clear trivalent chromate sealed.
 - c. Double acting steel springs and cable, both sides.
 - d. Rivets rated at 1100 lb (499 kg) shear strength each.
 - e. Steel section alignment clips at stringer section joints.
 - f. Molded rubber guards at corners of aluminum door panel.
 - g. Finishes: Mill finish on aluminum stairway components. Prime coat on frame.

2.3 FABRICATION

- A. Completely fabricate stairway ready for installation before shipment to the site.

PART 3 EXECUTION

3.1 EXAMINATION

- A. Do not begin installation until rough opening and structural support have been properly prepared.
- B. If substrate preparation is the responsibility of another installer, notify Architect of unsatisfactory preparation before proceeding.
- C. Examine materials upon arrival at site. Notify the carrier and manufacturer of any damage.

3.2 INSTALLATION

- A. Install in accordance with manufacturer's instructions.

3.3 PROTECTION

- A. Protect installed products until completion of project.
- B. Touch-up, repair or replace damaged products before Substantial Completion.

3.4 FIELD QUALITY CONTROL

The manufacturer has representatives in all areas of the United States and Canada. For the name of the closest representative, call (800) 225-7814.