



Instantaneous
SOUND RECORDING
EQUIPMENT and DISCS

PRESTO RECORDING CORPORATION

WORLD'S LARGEST MANUFACTURERS
of
INSTANTANEOUS SOUND RECORDING EQUIPMENT AND DISCS

Howell Recording Studio

2703 DELAWARE AVENUE
BUFFALO 17, N. Y.

Dymac, Inc.
2327-31 MAIN ST. PA. 2300
BUFFALO 14, N. Y.

**PRESTO**

RECORDING CORPORATION PARAMUS, NEW JERSEY

Address All Mail To: P.O. Box 500, HACKENSACK, NEW JERSEY

The contents of this catalog may not be reproduced as a whole or in part without written permission of PRESTO RECORDING CORP.

INTRODUCTION

THE Presto Recording Corporation manufactures recording and transcription equipment, associated amplifiers and accessories, and recording discs. These products are made available to the ultimate customer through a selected group of radio parts distributors chosen so as to adequately serve all sections of the country. Our accredited distributors carry an adequate stock of equipment and discs to serve the ultimate customer with the least possible delay. Certain of the heavier types of equipment may not be carried in stock but most distributors will have demonstrators on hand and will be able to obtain rapid delivery of additional units.

The Presto distributor is supervised in sales and technical matters by Presto factory representatives whose services are also available to the ultimate

customer for assistance in selecting equipment and for technical advice.

Foreign sales are handled by exclusive export agents and in Canada by an exclusive factory representative.

This catalog describes PRESTO Recording and Transcription equipment, associated amplifier units, accessories and replacement parts, and blank recording discs. The complete line of PRESTO recording discs, and cutting and reproducing styli are also described in a separate folder.

Two separate stuffers (3½" x 6¼") describing PRESTO discs and needles, and the PRESTO K-8 recorder are available for distributors' mailings.

United Catalog Publishing Co. pages describing our complete line are available to distributors for mailing and counter use.

IMPORTANT INFORMATION

Ordering

All merchandise should be ordered by description together with the type number or code word. When a group of associated equipment is specified, careful consideration should be given to the correct combinations of units and accessories. The representative and distributor can recommend the best combinations of equipment.

All shipments from the factory are F.O.B. New York City and are made by fast freight unless otherwise requested.

Presto is equipped with Western Union teleprinter — Address — Presto Recording Corp., WUX, New York.

Terms

Net 30 days. Prompt payment discount is not offered.

Modifications

The Presto Recording Corp. will occasionally modify the design of certain products and assumes no obligation to incorporate any of such modifications in equipment previously sold.

Guarantee

Presto equipment is guaranteed against defects in workmanship and materials for 90 days after receipt by the customer. For service under the guarantee the equipment should be returned, prepaid, to the distributor from whom purchased. Replacement equipment, if required, will be supplied through the distributor by Presto. Distributors and their customers should jointly complete

the guarantee card supplied with all equipment and return this card to Presto at the time the sale is made.

Authorization to return Merchandise

Presto equipment or discs will not be returned to the Presto plant for any reason without written permission. Persons wishing to return Presto products will request a Return Authorization. Return shipments will be subject to refusal from the carrier if a Return Authorization has not been issued to the sender by Presto. **Plant address is Route 4 and Forest Avenue, Paramus, N. J.**

Deductions

When all of the standard equipment normally included in any model is not desired, correct information regarding price deductions should be obtained. Full prices of most parts are not deductible.

Prices

Prices are subject to change without notice. Notice of proposed price changes will be given as far in advance of the effective date as is possible.

Prices are not shown in this catalog. Purchasers are to refer to the Presto NET CONSUMER PRICE SCHEDULE.

Distributors refer to LIST PRICE SCHEDULE when discounting.

CONTENTS

	Page		Page
COMPLETE RECORDING INSTALLATIONS			
Model A recorder	6-7	Re-recording turntable, type 140-A	38
Model F recorder	14-15	Re-recording pickup, type 141-A	38
Type 28-N	6-7	Pickup pedestal, 142-A	38
PORTABLE RECORDERS			
Model Y recorder	16-17	Screwdriver, type 502-A	25
Model K recorder	20-21	Spirit level, type 503-A	25
RECORDING TURNTABLES			
Model 8D and 8D-G recorders	10-11	Spring types 131-A and 131-B	37
Type 8-N	8-9	Table, mounting, type 12-A	6
Type 6-N	12-13	Table, mounting, type 93-A	15
Type 75-A, 75-B	18	Tire, rubber turntable, types 127-A and 127-B	37
Type 9-C	22	RECORDING AMPLIFIER EQUIPMENT	
TRANSCRIPTION TURNTABLE			
Model L	26	Limiter amplifier, type 41-A	34
Type 62-A	24-25	Preamplifiers, types 39-A and 39-B	35
Type 10-A	27	Preamplifiers, types 40-A and 40-B	36
Type 64-A	23	Recording amplifiers, types 85-A, B and E	30
TURNTABLE ACCESSORIES			
Cutting head, type 1-D	19	Recording amplifiers, types 87-A and B	31
Feed screws	37	Recording amplifier, type 90-A	28-29
Grommet, rubber, motor, type 220-A	37	Recording amplifier, type 92-A	32
Idle wheels, type 102-E and 103-E	37	Recording amplifier, type 89-A	33
Microscope, type 125-A	37	RECORDING DISCS	
Motor, type 145-A	37	Green Label Discs	40-41
Motor, type 146-A	37	Brown Label Discs	40-41
Automatic equalizer, types 160A/B	36	Orange Label Discs	40-41
Motor, type 147-A	37	Oversize Discs for Masters	40-41
Pickups, type 150-C and 150-D	37	Monogram Discs	40-41
Pulleys, motor drive, type 230-A, B, C, D	37	CUTTING STYLII	
Re-recording equipment, type 300-A	38	Sapphire Cutting Stylii	41
Pulleys, motor drive, type 231-A	37	Stellite Cutting Stylii	41
		Steel Cutting Stylii	41
		PLAYING NEEDLES	
		Sapphire Playing Needles	41
		Transcription Playing Needles	41
		Red Shank Playing Needles	41

INDEX to TYPE NUMBERS

	Page		Page
A recorder	6-7	93-A mounting table	14-15
F recorder	14-15	102-E idler wheel	37
K recorder	20-21	103-E idler wheel	37
Y recorder	16-17	104-A idler wheel	37
1-D cutting head	19	105-A idler wheel	37
3-A cabinet	25	116-E overhead feed mechanism	37
4-A cabinet	9	125-A microscope	37
5-A cutting head	37	127-A and 127-B rubber turntable tire	37
6-N recording turntable	12-13	128-N cutter feed mechanism	8-9
8-N recording turntable	8-9	131-A, 131-B, 131-C and 131-D counterbalance spring	37
9-C recording turntable	22	140-A re-recording turntable	38
8-D and 8-D-G recorders	10-11	141-A re-recording pickup	38
10-A turntable chassis	27	142-A pickup pedestal	38
12-A mounting table	6	145-A motor and bracket	37
28-N recording turntable	6-7	146-A motor	37
39-A, 39-B preamplifiers	35	147-A motor	37
40-A and 40-B preamplifier	36	148-A motor	37
41-A limiter amplifier	34	150-C, 150-D and 150-E pickup	37
62-A transcription turntable	24-25	160A/B automatic equalizer	36
64-A transcription turntable	23	200-A amplifier system	7
75-A, 75-B and 75-C recording turntable	18	220-A grommets, motor mounting, set	37
85-A, 85-B and 85-E recording amplifier	30	230-A, 230-B, 230-C, and 230-D motor pulley	37
86-C control panel	7	231-A motor pulley	37
87-A and 87-B recording amplifier	31	300-A re-recording equipment	38
89-A recording amplifier	33	502-A screwdriver	25
90-A recording amplifier	28-29	Replacement Parts	37
92-A recording amplifier	32	Feed Screws	37

PRESTO MODEL "A" RECORDER



THE model A recorder is composed of the finest grade of equipment throughout. Proof of its exceptional performance is the fact that it is used extensively by all three of the major broadcasting networks as well as the largest phonograph record manufacturers and commercial transcription studios. It makes lateral recordings that reproduce the widest frequency

range with the lowest background noise level possible to obtain under practical operating conditions.

The model A equipment forms two complete recording channels capable of recording continuously, recording two different 15 minute transcriptions simultaneously or making two duplicate transcriptions of the same 15 minute program.

SPECIFICATIONS

Standard Equipment: Includes one 28-N turntable unit and one 200-A amplifier unit.

The 28-N turntable unit is composed of two 8-N recording turntables mounted in a 12-A table equipped with 86-C control panel. The 200-A amplifier unit contains one 50-B radio tuner, two 85-B recording amplifiers, three 40-B pre-amplifiers, one 43-A line amplifier, one 130-B mixing panel, one 42-A patching panel and associated power supplies mounted and wired in a 68" fully enclosed relay rack. **Accessories required for the operation of this recorder include microphones, discs and needles.**

Frequency Response: Amplifiers, 30 to 15,000 cycles; uniform within 2 db; cutting heads, 50 to 10,000 cycles.

Pickups, for checking purposes only, 70 to 7,500 cycles.

Noise Level: Total of all electrical and mechanical noise, originating in equipment over 40 db below maximum useful sound level reproduced from the recordings.

Impedances: Inputs to pre-amplifiers 50/200 ohms. Input and output impedances of amplifiers 500 ohms. Cutters and pickups, 500 ohms. Radio tuner output, 500 ohms.

Gain: Pre-amplifiers, 36 db. Recording amplifiers, 90 db.

Radio Tuner: Band pass TRF type, tuning range 500 to 1750 kc. Average output level 0 db. Selectivity at 1,000 kc., minus 5 db at 18 kc. limits.

Power Output: Recording amplifiers, 10 watts.

Tube Complement: Preamplifiers, 1st 6-S-Q-7—2nd 6-S-J-7. Recording amplifiers 1st stage 2 type 6-S-J-7; 2nd stage 2 type 6-S-J-7; 3rd stage 2 type 6-L-6's P.P.; rectifier type 5Z3. Radio tuner 1st 6-S-K-7, 2nd 6-S-K-7 detector 6-H-6, 1st Audio 6-C-5, Rectifier 5-Z-4. Preamplifier Power Supply rectifier 1 type 80. Line amplifier 1st stage 2 6-S-J-7; 2nd stage one 6-S-N-7.

Controls: The 86-C panel contains controls for two independent recording channels each consisting of a gain control, cutter and equalizer changeover switches for continuous recording, volume indicator meter and a switch for selecting the equalizer peak frequency. Also, a selector switch for each recording table which connects the cutting head and equalizer control to either amplifier channel. In addition, there is a pickup changeover key. Amplifier controls include the radio tuner dial, power switch and volume control, the selector switches for connecting the amplifiers to play or record from the radio, playback records, record from the microphone or operate as a Public Address system. Separate volume controls are supplied on each amplifier; also, three mixer controls on the outputs of the preamplifiers. Toggle switches change the input impedance of the preamplifiers to 50/200 ohms as desired.

The 42-A patching panel contains 24 double jacks for connections to various program lines. Connections for the turntables, microphones and power leads are brought out to terminal blocks at the rear of the cabinet.

Microscope: Magnification, 40 power, equipped with extension arm and light. Field in focus, 7 grooves.

Cutting Pitch: Standard feedscrews cut 112 lines an inch, inside-out. Feedscrews for 96 or 120 lines an inch inside-out, or outside-in substituted at purchaser's request.

Speed Accuracy: Within .5% at both 78 and 33 $\frac{1}{3}$ RPM. Regulation within a single revolution is accurate to .25%.

Power Requirements: Standard equipment draws 500 watts on a 110 volt, 60 cycle line. Available for other voltages and frequencies without additional charge.

Operating Clearances: Overall clearance required for 28-N turntable unit; L-64" X D-32" X H-53" (163 X 81 X 135 cm.) The 12-A table mounts the turntables 44" (112 cm.) above the floor level for operating from a standing position. Amplifier dimensions are W-23" X D-18" X H-68" (58 X 46 X 173 cm.).

Finish: The 12-A table is finished in smooth gray enamel, all metal parts in gray crackle enamel with chromium trim.

Shipping Dimensions and Weight for Model A Recorder: The complete model A Recorder is packed for shipment in three cases.

Case No. 1 contains: 28-N recorder less overhead mechanisms, microscopes, idler wheels and pickup heads.

Case No. 2 contains: 200-A rack amplifier, less tubes.

Case No. 3 contains: Overhead mechanisms, microscopes, idler pulleys, pickup heads, and tubes.

TYPE	DESCRIPTION	PRICE	CODE
28-N	Turntable Unit		AMORE
200-A	Amplifier Unit		AMANK

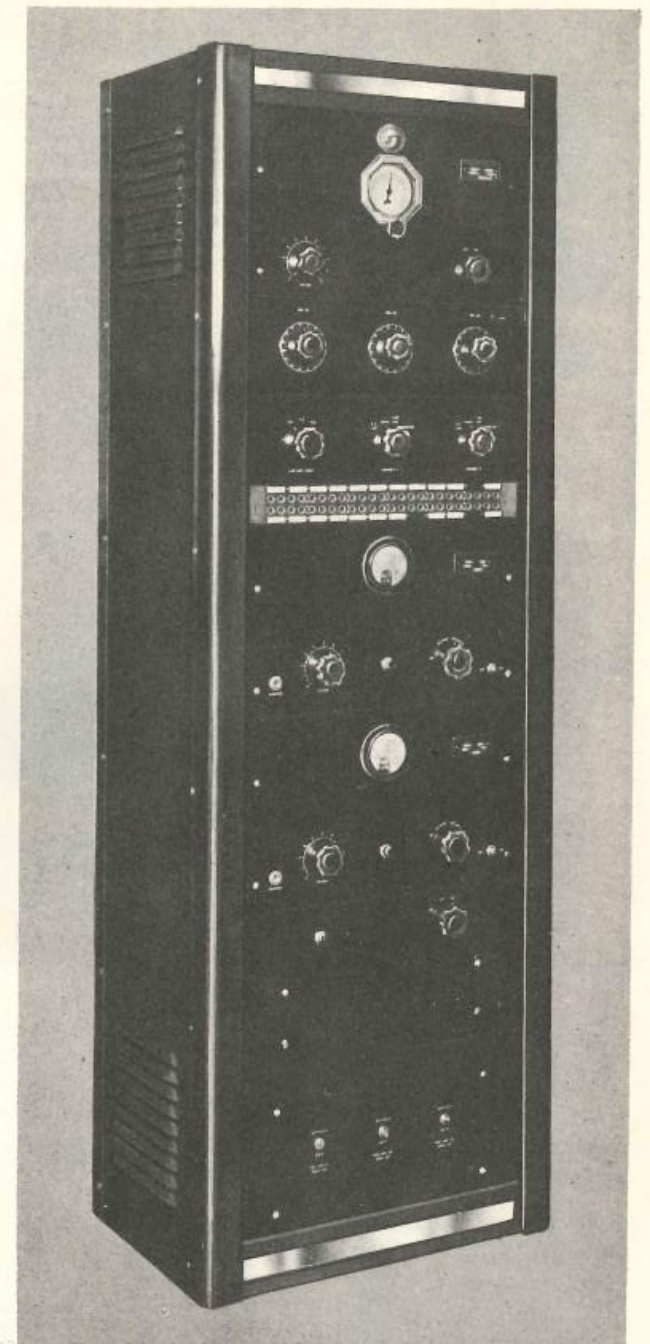

TYPE 200-A AMPLIFIER UNIT

The 28-N recorder packed for shipment weighs 620 lbs. (281 kg.). The 200-A rack amplifier packed for shipment weighs 490 lbs. (222 kg.). The accessories packed for shipment weigh 125 lbs. (57 kg.).

PRESTO 8-N RECORDING TURNTABLE

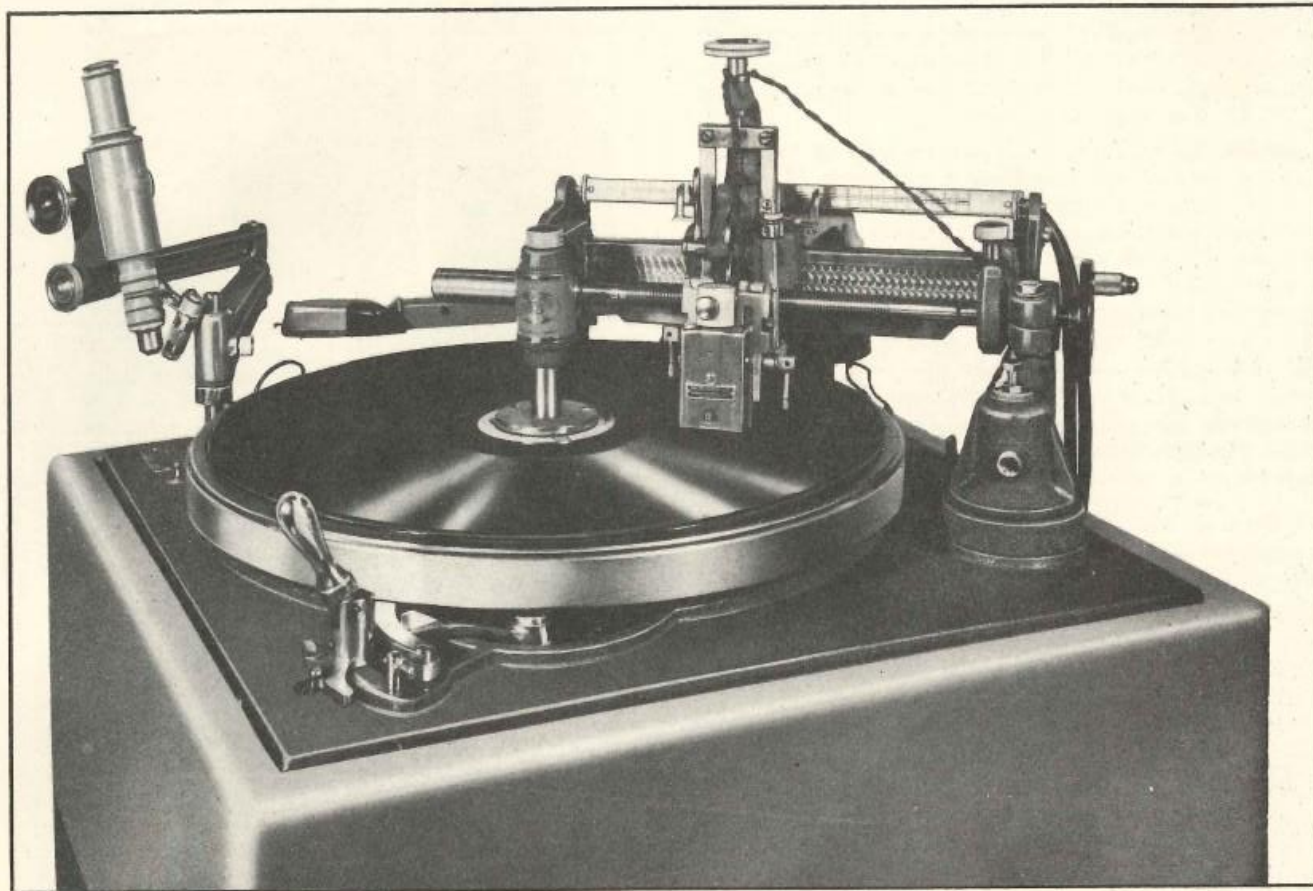

A PRECISION instrument embodying the finest materials and workmanship throughout, designed in collaboration with engineers of the largest recording studios to include all of the operating conveniences necessary to produce consistent, high quality work.

Added weight and size in the turntable, turntable bearing, mounting base and overhead mechanism serve to

keep this equipment in perfect operating condition over long periods without adjustment, a feature of primary importance in busy recording studios.

The 8-N turntable records the widest frequency range with the lowest background noise obtainable on lateral recordings. It is particularly recommended to studios making master recordings for the production of commercial pressings.

SPECIFICATIONS

Standard Equipment: The 8-N recorder consists of a turntable, motor drive system and overhead cutting mechanism mounted on a cast iron base equipped with shockproof mountings. The 128-N cutting mechanism includes the 1-D high fidelity cutting head, 15-B spiralling feed-screw, 20-A time scale, 170-B vertical damper and 160-A automatic equalizer. Also included are the 125-A microscope and 150-C pickup. Accessories necessary to operate the 8-N table include recording amplifier, microphone, discs and needles.

Turntable: Cast iron, accurately machined and dynamically balanced, weight 20 lbs., equipped with a hardened steel shaft which revolves on a single ball bearing at the base of a bronze shaft well. Provision is made for tightening the bearing to compensate for wear.

Drive System: A heavy duty, self-starting synchronous motor applies power to the inside rim of the turntable through a steel pulley and two specially designed rubber idler wheels, one for 78 RPM and the other for 33 $\frac{1}{3}$ RPM. The speed shift lever operates the motor switch and engages the idler wheels. Provision is made for locking the speed shift lever in place. Adjustable stops regulate the pressure against the idler wheels.

Mounting Base: Cast iron, weight 60 lbs., provided with four shockproof mountings to attenuate vibration from external sources.

Cutting Mechanism: The 128-N cutter mechanism consists of a heavy machined guide bar which swings from a post mounted on the base. A flange which fits over the turntable shaft drives the feedscrew through a worm and

gear. The entire mechanism moves to a rest at the rear of the turntable when not in use. Provision is made for quickly adjusting the alignment of the cutting mechanism with the turntable and base. The spiralling attachment makes it possible to space grooves up to $\frac{1}{2}$ " apart at convenient crank speeds. The time scale is foursided showing elapsed recording time at pitches of 96, 104, 112 or 120 lines an inch.

Cutting Head Carriage: The cutting head is mounted on an apron, hinged to permit a rough adjustment of the cutting angle. This adjustment is locked by means of a thumbscrew. Fine adjustment of the cutting angle is made by the large thumbscrew at the top of the carriage. The cutting head may be swung outward to change cutting needles and replaced without disturbing the cutting angle. Levers are provided for lowering the cutting needle on the disc and for engaging the carriage with the feed screw. The vertical damper is mounted on a rocker arm beneath the carriage. Feedscrews can be changed quickly by loosening one thumbscrew. The depth of cut is adjusted by a counterbalance spring.

Microscope: Magnification 40 power, area in focus, 7 grooves, equipped with rigid cast iron mounting bracket, lamp and reflector.

Frequency Response: Cutting head 50 to 10,000 cycles, pickup 70 to 7,500 cycles.

Noise Level: Mechanical noise originating in equipment over 40 db below maximum useful sound level reproduced from recordings.

Impedances: Cutting head 500 ohms, pickup 500 ohms.

Cutting Pitch: Standard feedscrew cuts 112 lines an inch inside-out. Feedscrews for 96, 104 or 120 lines an inch inside-out or outside-in substituted at purchaser's request.

Speed Accuracy: Within .5% at both 78 and 33 $\frac{1}{3}$ RPM. Regulation within a single revolution accurate to .25%.

Power Requirements: Turntable motor draws 100 watts from a 110 volt 60 cycle line. Available for 50 cycles or 220 volts at no additional charge.

Operating Clearances:

Overall clearance necessary for operating 8-N chassis only: W-27" x D-27" x H-18". (69 x 69 x 46 cm.).

Mounting dimension of base: 20" x 20". (51 x 51 cm.).

Operating clearances for 8-N table: in cabinet H-53" x W-27" x D-27". (135 x 69 x 69 cm.).

The 4-A cabinet mounts the turntable 44" (112 cm.) above floor level, suitable for operating from a standing position.

Finish: The 4-A cabinet is finished in smooth gray enamel. Metal parts of the 8-N equipment are finished in gray crackle enamel with chromium trim.

Shipping Dimensions and Weights for the 8-N Turntable:

Case No. 1 contains: The 8-N recorder, less overhead mechanism, microscope, idler wheels and pickup head. Weighs 120 lbs. (54 kg.).

Case No. 2 contains: The overhead mechanism, microscope, idler wheels and pickup head. Weighs 55 lbs. (25 kg.).

Case No. 3 will contain: The 4-A cabinet if ordered. Weighs 70 lbs. (32 kg.).

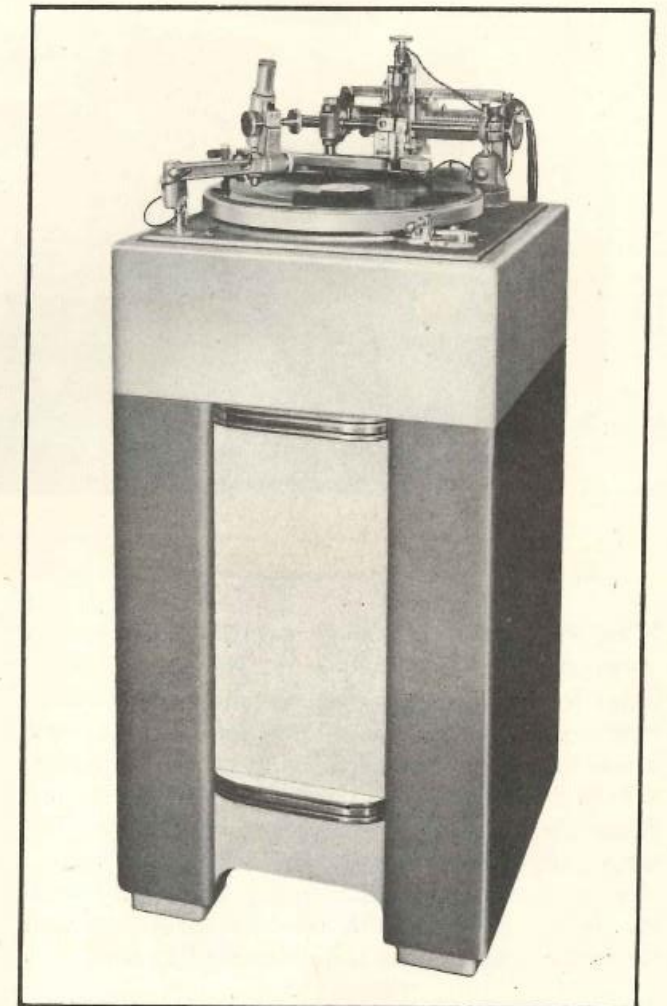

TYPE	DESCRIPTION	PRICE	CODE
8-N	Recording turntable chassis only		ALLEX
8-N	Recording turntable in 4-A cabinet		ALBAB

PRESTO 8D and 8D-G RECORDERS

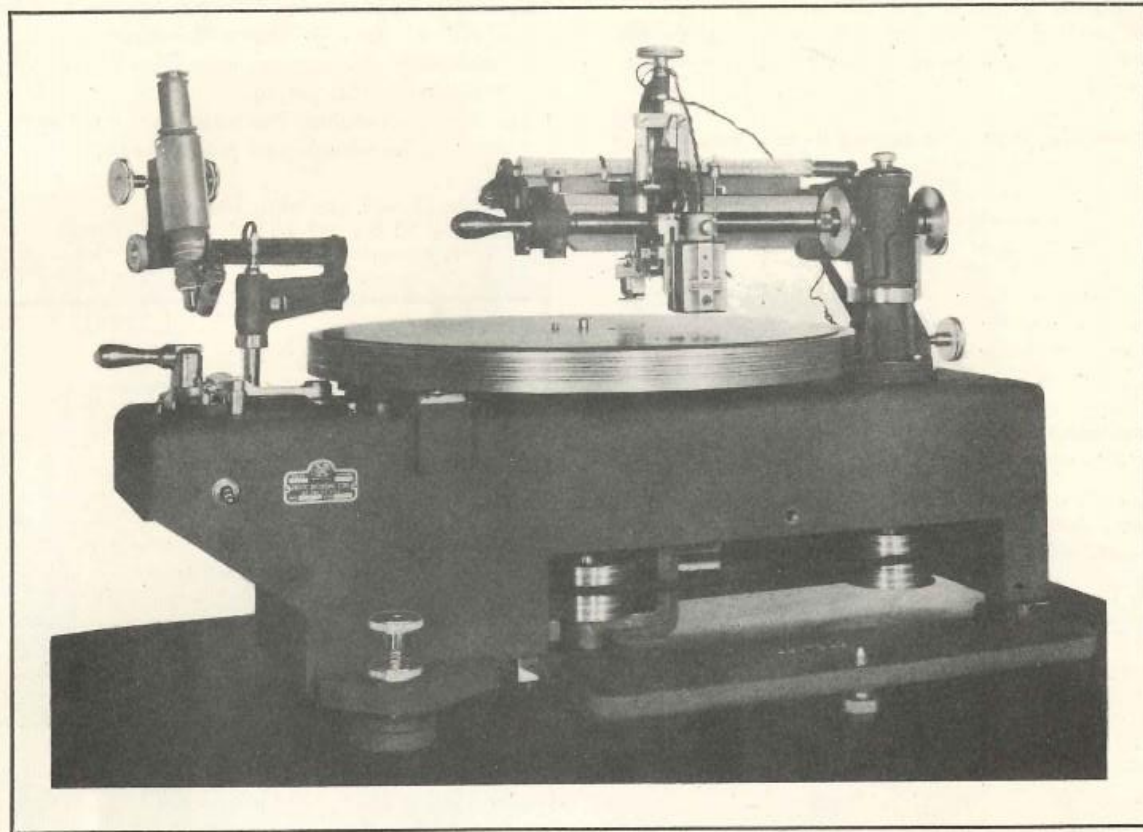

THE Presto 8D and 8D-G recorders represent a marked improvement in the design of equipment for the most exacting requirements. Broadcast stations, recording studios, laboratories, and educational institutions offering courses in radio, will find this type of equipment adequate for the finest instantaneous and master recordings. The equipment has proven its ability to stand up under continuous operation for long periods of time. Its design provides the operator with unusual flexibility and easy manipulation of controls.

The 8D and 8D-G are identical except the former is a rim driven type and the latter is directly gear driven at both $33\frac{1}{3}$ and 78.26 rpm. The 8D may be purchased without a cabinet but a cabinet is always included with the 8D-G because the drive mechanism is mounted at the factory as an integral part of the whole assembly. The 8D recorder consists of a heavy cast iron base containing the motor and driving idlers, the turntable bearing and the multiple grooved pulleys controlling the cutting pitch. The overhead is a cantilever firmly supported at its right end and arranged to

swing to the rear when changing records. No contact with the turntable is required. The feed screw driven by a shaft passing up through the support casting at the right hand end of the overhead assembly has a built-in reversing gear for changing direction of feed.

The 8D-G is equipped with a direct gear drive in place of the rim drive of the 8D. Separate motors are employed for $33\frac{1}{3}$ and for 78.26 rpm and selection of speed is made by actuating a special double-throw mercury switch. The design of the drive has completely eliminated the need for a mechanical speed change. Both motors are always engaged mechanically but only one motor at a time is in operation — the other motor remains at rest and is not carried along by the rotating mechanism. Adequate isolation of the drive mechanism from the turntable is accomplished by a mechanical filter. The design and construction of the transmission unit produces a mechanism of extreme accuracy which is, nevertheless, very rugged and composed of unusually few parts.

SPECIFICATIONS

Speed Accuracy: For 8D-G, no deviation from $33\frac{1}{3}$ and 78.26 rpm. For 8D, within 0.5% at both $33\frac{1}{3}$ and 78.26 rpm.

Pitch: Adjustable to cut 88, 96, 104, 112, 120, 128 or 136 lines per inch, inside-out or outside-in with the same feedscrew.

Noise Level: Mechanical noise originating in the 8D-G equipment over 50 db below program level; in the 8D equipment over 40 db below program level.

Impedance: 1-D cutting head 500 ohms; 15 ohms available.

Frequency Response: 50 - 10,000 cps. Refer to 1D circular.

Power Requirements: Approximately 100 watts from a 115 volt, 60 cycle, single phase line. Motors are of the 1800 rpm synchronous type and are available for other voltages and frequencies at additional cost.

Microscope: Magnification 40 power, area in focus — 7 grooves, equipped with rigid cast aluminum mounting bracket and a special lamp for illumination of the grooves.

Operating Clearances: 8D-G overall clearance 35 x 23 x 53 inches (89 x 58 x 135 cm); 8D without cabinet 31 x 18 x 19 $\frac{1}{4}$ inches (79 x 46 x 49 cm).

Shipping Dimensions and Weights: The 8D-G is packed in two wooden crates. Crate No. 1 containing the recorder, gear drive and cabinet, is 41 x 30 x 56 inches (104 x 76 x 142 cm). Weight: 572 lbs (258 kg); Crate No. 2 containing the turntable, microscope, control box or panel, stroboscope, and dash pot fluid is 26 x 19 x 18 inches (66 x 48 x 46 cm). Weight: 53 lbs (24 kg). The 8D is packed in two wooden crates. Crate No. 1 containing the recorder, without cabinet, is 36 x 23 x 24 inches (91 x 58 x 61 cm). Weight: 153 lbs (69 kg); Crate No. 2 containing the turntable, microscope, control box or panel, stroboscope, dash pot fluid, and idler wheels is similar to crate No. 2 of the 8D-G.

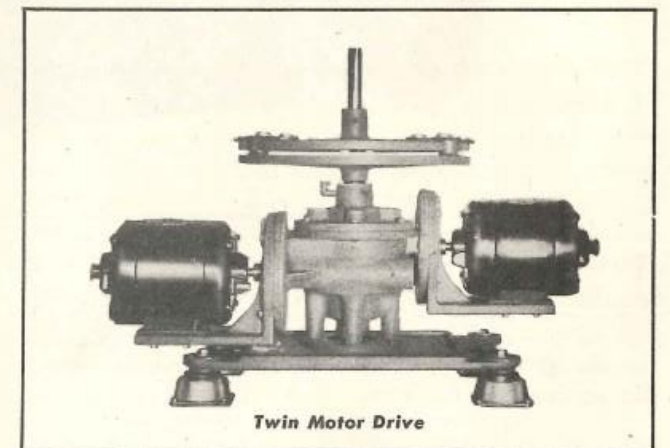
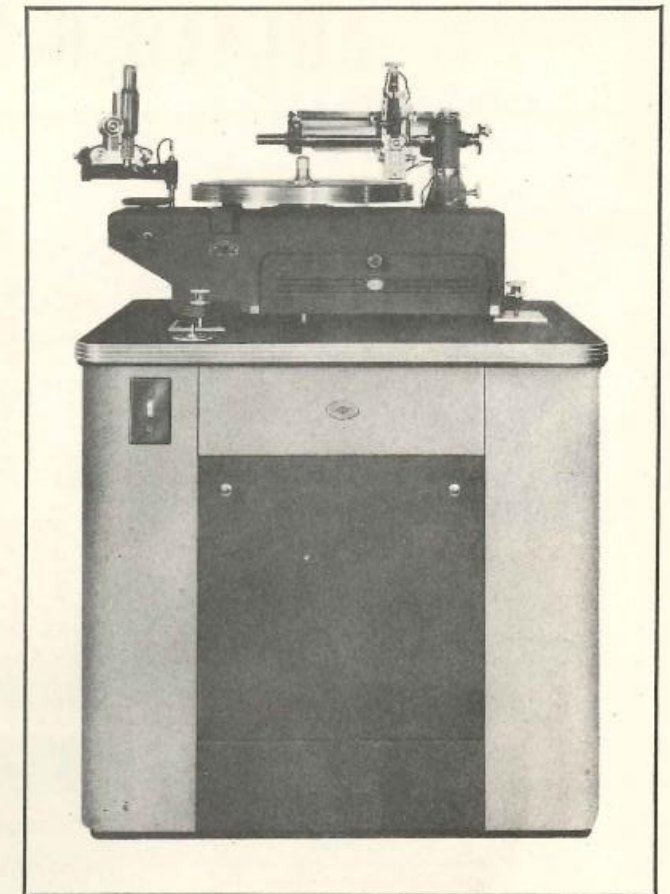

PRESTO 6-N Turntable



THE PRESTO 6-N recording turntable is offered as a replacement unit for the Presto 6-D recording turntable over 1500 of which are now in operation in broadcasting stations and instantaneous recording studios. It includes all the basic equipment needed to make recordings of commercial quality.

The 6-N recorder is an improvement on the 6-D in the following respects:

1. The overhead cutting mechanism has been redesigned so that it is removable as a unit from the turntable and fits into a pocket inside the carrying case for safer transportation.
2. The cutting head mounting has been redesigned so that the weight rests entirely on two slider bars. This facilitates changing feedscrews and gives more accurate groove spacing.
3. Mechanical vibration is greatly reduced by the use of a heavier turntable base in which the turntable bearing and overhead cutting mechanism mounting are cast as an integral part preventing changes in alignment with age or use.
4. The speed shift lever has a locking arm which holds it firmly in place against the stop pin.
5. The design of the overhead mechanism permits quick alignment of the mechanism with the turntable.

SPECIFICATIONS

Standard Equipment: The 6-N recording turntable consists of a turntable, motor drive system and overhead cutting mechanism mounted on a cast aluminum base. The 116-N overhead cutting mechanism includes the 1-D high fidelity cutting head, 15-B spiral-

ling feed screw, the 170-A vertical damper and the 20-A time scale. Accessory equipment which may be added to the 6-N recorder if desired includes the 160-A automatic equalizer, the 125-A microscope and the 1-B carrying case or 4-A wood mounting cabinet.



6-N chassis in a 4-A floor mounting cabinet

Turntable: Cast aluminum accurately machined and dynamically balanced. Weight 10 lbs. Equipped with a hardened steel shaft which revolves on a single ball bearing at the base of a bronze bushed shaft well.

Drive System: A self-starting, synchronous motor applies power at the inside rim of the turntable through a steel pulley and two rubber idler wheels, one for 78 RPM, the other for 33 $\frac{1}{3}$ RPM. The speed shift lever operates the motor switch and engages the idler wheels. Adjustable stops regulate the pressure against the idler wheels. . .

Mounting Base: Cast aluminum heavily ribbed for rigidity. 10 lbs. heavier than base previously furnished with 6-D recorder.

Cutting Mechanism: The 116-N cutter mechanism swings from a cast, bronze bushed bearing in the turntable base. A flange which fits over the turntable shaft drives the feed screw through a worm and gear. The entire mechanism moves to a rest at one side of the turntable when not in use. Provision is made for quick, accurate alignment of the cutting mechanism with the turntable and base. The spiralling feed screw makes it possible to space grooves up to $\frac{1}{2}$ " apart at convenient crank speeds. A time scale shows the elapsed recording time at both 78 and 33 $\frac{1}{3}$ RPM at cutting pitches of 96-104-112 and 120 lines an inch.

Cutting Head Carriage: The cutting head is mounted on an apron, hinged for quick adjustment of the cutting angle. A cam lever is provided for lowering the cutting needle on the disc. A knob on the cutter carriage lowers the feed finger under spring tension on the feed screw. The vertical damper for eliminating rumble or flutter due to vertical modulation is mounted beside the cutter carriage. The depth of cut is adjusted by a counterbalance spring. Feed screws can be changed quickly by loosening one thumb screw. The



Overhead mechanism is carried inside case.

driving gear on the feed screw is permanently mounted and engaged with the worm on the drive shaft so that it cannot be damaged when feed screws are changed.

Frequency Response: Cutting head 50 to 10,000 cycles, pickup 70 to 7,500 cycles.

Noise Level: Mechanical noise originating in equipment 35-40 db below maximum useful sound level reproduced from recordings.

Impedances: Cutting head 15 ohms or 500 ohms as ordered, pickup 500 ohms.

Cutting Pitch: Standard feed screw cuts 112 lines an inch inside-out. Feed screws for 96, 104 or 120 lines an inch inside-out or outside-in substituted at purchaser's request.

Speed Accuracy: Within .5% at both 78 and 33 $\frac{1}{3}$ RPM. Regulation within a single revolution accurate to .25%.

Power Requirements: Turntable motor draws 60 watts from a 110 volt 60 cycle line. Available for 50 cycles or 220 volts at no additional charge.

Operating Dimensions and Weight: With case closed the 6-N turntable measures 20 $\frac{1}{4}$ " x 20" x 15" (52 x 51 x 38 cm.), weighs 82 lbs. (37 kg.).

Finish: Carrying case, gray leatherette, cabinet two tone gray enamel, metal parts gray enamel with chromium trim.

Shipping Dimensions and Weight: The 6-N table is packed for shipment in a case measuring 36" x 28" x 19" (91 x 71 x 48 cm.), weighing 140 lbs. (64 kg.).

TYPE	DESCRIPTION	PRICE	CODE
6-N	Turntable chassis only		DONOR
6-N	Turntable in 1-B carrying case		DONEB
6-N	Turntable in 4-A cabinet		DOANE

PRESTO MODEL "F" RECORDER



A MEDIUM priced recording installation for radio stations that record half hour programs for delayed broadcasts, schools that record half and one hour educational programs and personal recording studios that require facilities for duplicating records or re-recording 15 minute transcriptions on 78 RPM records

that can be played in the home... Equipped with the highest quality Presto cutting heads and an amplifier designed especially for recording, the model F recorder may be expected to make records comparable in quality to those made on the highest priced equipment.

SPECIFICATIONS

Standard Equipment: The model F recorder consists of two 75-A 16" recording turntables and an 87-C amplifier completely wired and mounted in the 93-A table.

The 16" dual speed turntables are equipped with Presto high fidelity cutting heads, vertical dampers, time scales and an underneath cutter feed mechanism that may be adjusted instantly to cut from outside-in or inside-out.

The amplifier includes a two microphone mixer and high and low frequency equalizers which make it possible to produce recordings with exceptionally low background noise. **Accessories necessary to operate the recorder include microphones, loudspeaker, discs and needles which must be ordered separately.**

Frequency Response: Amplifier, adjusted for flat response, 30 to 10,000 cycles. Turned to the right the treble control produces a maximum peak of 17 db. at 6,500 cycles. Turned to the left it acts as a scratch filter giving a maximum attenuation of 20 db. at 5,000 cycles. The bass control produces a maximum peak of 20 db. at 100 cycles. Cutting head response 50 to 10,000 cycles. Pick-ups for checking purpose only, 70 to 7500 cycles.

Noise Level: Total of all electrical and mechanical noise, originating in equipment, over 35 db. below maximum useful sound level reproduced from the recordings.

Tube Complement: First stage 2 type 6SJ7's; Radio stage, 1 type 6SJ7; 2nd and 3rd stage 1 type 6SL7-GT; 4th stage (phase inverter) 1 type 6SN7-GT; power stage 2 type 2A3's push-pull, and rectifier 5Z3.

Impedances: Microphone inputs 50, 200 or 500 ohms as specified by purchaser. Line input jack 500 ohms. Amplifier output 8 ohms. Cutter 8 ohms. Pickup 500 ohms.

Gain: Amplifier, adjusted for flat response, 115 db.

Power Output: Amplifier, 10 watts.

Controls: Amplifier controls include two micro-

phone input gain controls, playback volume control and continuously variable treble and bass equalizer controls, a switch for changing instantly between cutting heads and pickups and a selector switch which connects the amplifier for recording, playback or public address operation. Amplifier panel also contains a volume indicator meter, telephone line input jack, monitor jack, two turntable receptacles, two microphone receptacles and a power switch.

Speed Accuracy: Within .5% at both 78 and 33 1/3 RPM. Regulation within a single revolution is accurate to .25%.

Cutting Pitch: 112 lines an inch, inside-out or outside-in, permitting a full 15 minute recording on one side of a 16" disc.

Power Requirements: Standard equipment draws 250 watts on a 110 volt, 60 cycle line. Available for 220/240 volts or 50 cycles at no additional cost.

Finish: The 93-A table and amplifier panel are finished in smooth gray enamel. Turntables are finished in gray crackle enamel with chromium trim.

Operating Clearances: Overall clearances required for operating recorder 67x19x52" (171x 48 x 132 cm.). The 93-A table mounts the turntables 33" (84 cm.) above the floor level suitable for operation from a sitting position. Amplifier panel is hinged to move forward for tube replacement.

Shipping Dimensions and Weight: The complete Model F recorder is packed for shipment in one case measuring 71x23x56" (181x59x143 cm.) weighing 350 lbs. (160 kg.).

TYPE	DESCRIPTION	PRICE	CODE
F-1	Complete recording installation		FENCE

PRESTO MODEL "Y" RECORDER

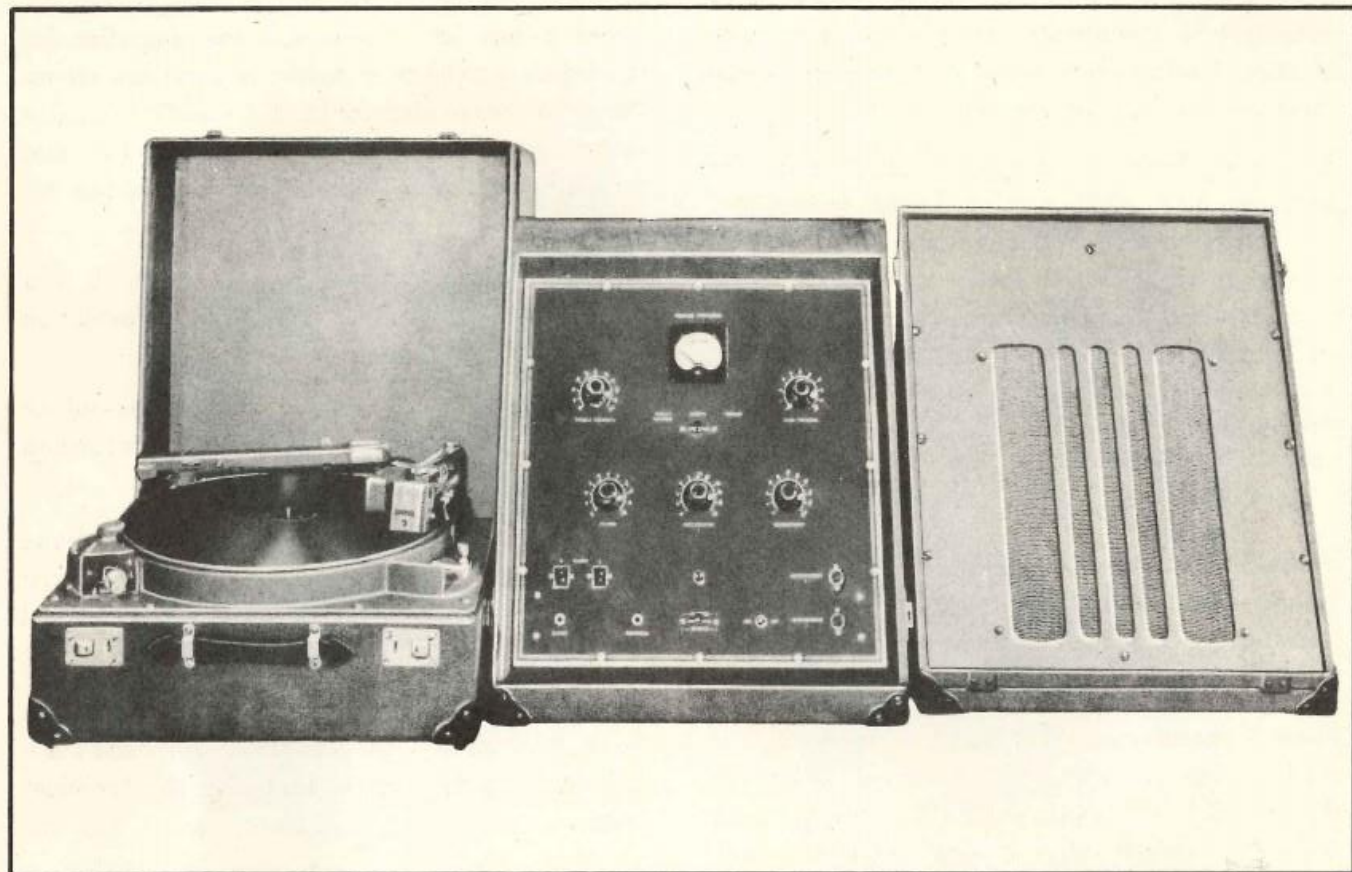

THE PRESTO model Y recorder fills the need for a 16" transcription recording and playback equipment which is extremely portable and yet capable of producing high grade recordings. It makes continuous 15 minute, 33 1/3 RPM electrical transcriptions of sufficiently good quality to be used by broadcasting stations. It also makes 78 RPM recordings on 6", 8", 10" or 12" discs and may be used to cut 11 1/2", 13 1/2" and 17 1/4" master recordings from which commercial pressings are produced. In addition to recording, the model Y gives excellent reproduction of both electrical transcriptions and phonograph records and is widely used for auditioning recorded radio programs to prospective sponsors. As a public address system it will provide sound for audiences up to 500 persons.

Among the important features of the model Y recorder are:

1. The exclusive Presto rubber-rimmed-turntable driven directly by a steel pulley on the motor shaft, a simple,

foolproof drive system that eliminates vibration and holds the turntable speed constant. Maintenance is negligible.

2. A lever changes the turntable speed instantly without stopping the table or removing the record.

3. A lever adjusts the cutting mechanism to cut either from the outside of the disc toward the center or from the center out.

4. A switch on the amplifier panel shifts the amplifier output instantly from one cutting head to another. Programs running an hour or more may be recorded without interruption if two turntables are used.

5. A cam lever lowers the cutting head gently on the record preventing accidental damage to sapphire needles.

6. A vibration damper attached to the cutting head suppresses vertical modulation in the record groove and eliminates variation in groove depth due to surface irregularities in the disc.

7. The cutting arm may be unlocked from the feed mechanism to cut spiral starting and runout grooves.

8. A time scale on the cutting arm shows the starting point for each size record and elapsed recording time at both 78 and 33 1/3 RPM.

9. The cutting head feed mechanism is located beneath the turntable where it is protected from dust or accidental damage. The parts of this mechanism are hand

finished and fitted and its performance is equal in every way to the overhead lathe type mechanism commonly used.

10. The recording amplifier includes a two microphone mixer, high and low frequency equalizers and a change-over switch for continuous recording or re-recording. The amplifier and loudspeaker fit together to carry in a single case.

SPECIFICATIONS

Standard Equipment: The model Y-2 recorder consists of one 75-A recording turntable and one 87-A recording amplifier and loudspeaker. The model Y-4 recorder consists of one 75-A recording turntable and one 87-B recording amplifier. The 87-B amplifier is identical with the 87-A except that it includes input transformers for low impedance microphones. **Accessories necessary to operate the recorder include microphones, stands, discs and needles which must be ordered separately.**

Frequency Response: Amplifier, adjusted for flat response, 30 to 10,000 cycles. Turned to the right the treble control produces a maximum peak of 17 db at 6,500 cycles. Turned to the left it acts as a scratch filter giving a maximum attenuation of 20 db at 5,000 cycles. The bass control produces a maximum peak of 20 db at 100 cycles. Cutting head response 50 to 10,000 cycles. Pickup, for checking purposes only, 70 to 7,500 cycles.

Noise Level: Total of all electrical and mechanical noise, originating in equipment, over 35 db below maximum useful sound level reproduced from recordings.

Tube Complement: First stage 2 type 6SJ7's; Radio stage, 1 type 6SJ7; 2nd and 3rd stage 1 type 6SL7-GT; 4th stage (phase inverter) 1 type 6SN7-GT; power stage 2 type 2A3's push-pull, and rectifier 5Z3.

Impedances: Microphone inputs, 87-A amplifier, 100,000 ohms; 87-B amplifier 50, 200 or 500 ohms as specified by purchaser. Line input jack 500 ohms. Amplifier output 8 ohms. Pickup 500 ohms. Cutter 8 ohms.

Gain: Amplifier, adjusted for flat response, 115 db.

Power Output: Amplifier, 10 watts.

Controls: Amplifier controls include two microphone input

gain controls, playback gain control and continuously variable treble and bass equalizer controls, a switch for changing instantly between cutting heads and pickups, (when two turntables are used) and a selector switch which connects the amplifier for recording, playback or public address operation. Amplifier panel also contains a volume indicator meter, telephone line input jack, monitor jack, two turntable receptacles, two microphone receptacles and a power switch.

Loudspeaker: Ten inch, permanent magnet, dynamic with enclosed baffle.

Speed Accuracy: Within .5% at both 78 and 33 1/3 RPM. Regulation within a single revolution is accurate to .25%.

Cutting Pitch: 112 lines an inch, inside-out or outside-in permitting a full 15 minute recording on one side of a 16" disc.

Power Requirements: Standard equipment draws 180 watts on a 110 volt, 60 cycle line. Available for 220/240 volts or 50 cycles at \$10 additional cost.

Mounting. Re-inforced carrying cases covered in gray airplane luggage cloth equipped with chromium plated locks and leather handles. Metal parts of recorder gray enamel with chromium trim.

Operating Weights & Dimensions: Turntable case closed 20 1/2"x11"x19" (52x28x50 cm.). Weight 49 lbs. (22 kg.). Amplifier case closed 23 1/2"x12"x20" (60x31x51 cm.). Weight 57 lbs. (26 kg.).

Shipping Weights & Dimensions: Turntable, one case measuring 33"x25"x14" (84x62x35 cm.), weighing 68 lbs. (31 kg.). Amplifier, one case measuring 35 1/2"x26"x16" (90x66x41 cm.), weight 85 lbs. (39 kg.).

TYPE	DESCRIPTION	PRICE	CODE
Y-2	Recorder		YACHT
Y-4	Recorder		YACRE

NOTE: Order should specify Amplifier Input Impedance

PRESTO Type 75-A and 75-B Recording Turntables

THE lightest 16" dual speed recording turntable made. Recommended for all services requiring a high grade portable recorder. Widely used by broadcasting stations that record local news events for delayed broadcasts; a rugged, compact recording installation for mobile pick-up units.

Used by industrial concerns, hospitals, scientific laboratories and in the visual education departments of schools and colleges in conjunction with 16 mm sound-film projectors for recording and reproducing narrative comment, sound effects and background music with locally produced silent films.

An ideal turntable unit for installation in custom built radio sets designed for owners who wish to reproduce electrical transcriptions and to record complete operatic and symphonic radio programs or educational broadcasts.

SPECIFICATIONS

Standard Equipment: The equipment consists of a 16" cast aluminum turntable, carefully machined to dynamic balance, weighing 10 lbs. It revolves on a single ball bearing at the base of a bronze shaft well. A heavy live rubber tire on the rim of the turntable engages with a steel, step-pulley on the motor shaft to drive the table. The motor is suspended by rubber grommets in a carriage which is moved up or down by a lever to change the turntable speed. The motor drive and turntable are mounted in a cast aluminum base designed to combine extreme rigidity with light weight. The cutting mechanism consists of a fan gear, worm and pinion driven by a worm on the turntable shaft. The 1-D high fidelity cutting head, 171-A vertical damper, 21-A time scale and 150-C lateral pickup are included as standard equipment. The 75-A table is mounted in the 2A carrying case. The 75-B turntable is mounted in the 3-A cabinet. **Accessories necessary to operate the turntable include recording amplifier, microphone, discs and needles which must be ordered separately.**

Frequency Response: Cutting head 50 to 10,000 cycles, pickup 70 to 7,500 cycles.

Noise Level: Total of mechanical noise originating in equipment 35 db below maximum useful sound level reproduced from the recordings.

Speed Accuracy: Within .5% at both 78 and 33 $\frac{1}{3}$ RPM. Regulation within a single revolution accurate to .25%.

Impedances: Cutting head 8 ohms, pickup 5,000 ohms. Cutting head impedance changed to 15 or 500 ohms, pickup impedance to 200 or 500 ohms at purchaser's request.

Amplifier Requirements: Maximum power level required for cutting head plus 23 db, average gain required to raise pickup output to 0 db level, 55 db. (Ref. .006W).

Cutting Pitch: 112 lines an inch, outside-in or inside-out by shifting a lever.

Power Requirements: Motor draws 60 watts on a 110 volt, 60 cycle line. Available for 110 volts—50 cycles, 220/240 volts—50 cycles or 220 volts—60 cycles, at no additional charge.

Finish: Turntable, gray enamel with chromium trim, 2-A case gray leatherette, 3-A cabinet two tone gray enamel with silver trim.

Operating Dimensions and Weight: 75-A table, case closed 11" x 19" x 20 $\frac{1}{2}$ " (28 x 48 x 52 cm.). Weight 49 lbs. (22 kg.). 75-B table, 37" x 21" x 22 $\frac{1}{2}$ " (94 x 53 x 57 cm.).

Shipping Dimensions and Weight: 75-A table, 31" x 24 $\frac{1}{2}$ " x 14" (79 x 62 x 26 cm.). Weight 74 lbs. (33 kg.).

75-B table, 35" x 29" x 42" (89 x 74 x 107 cm.). Weight 85 lbs. (38 kg.).



TYPE 75-A RECORDING TURNTABLE



TYPE 75-B RECORDING TURNTABLE

PRESTO TYPE 1-D CUTTING HEAD

THE 1-D cutting head has been designed to meet the high fidelity standards required by the broadcast industry. This head represents essentially a multi-section mechanical band pass filter which is terminated with the aid of Prestoflex — a new damping material developed and manufactured by Presto. Due to the use of Prestoflex, temperature variations have very little influence on the response and sensitivity of the 1-D cutter between 60° and 95°F. The frequency response in this range does not vary more than $\pm 2\frac{1}{2}$ db. At low temperature the loss in sensitivity is on the average less than 2 db. Prestoflex makes the 1-D much more stable with temperature than a viscoloid-damped unit. The heating effect of the signal currents flowing through the coils is negligible, and at normal recording levels a sinusoidal steady signal, even if applied for several minutes, does not cause any change in the characteristics of the 1-D cutter.

Cancellation of the even harmonics is achieved by the double coil, push-pull construction, and also by the use of an accurately machined and carefully balanced armature. The proper choice of the magnetic characteristic of the armature material reduces odd harmonics to a very low value. Eddy current losses, which are unavoidable at higher frequencies, are kept to a minimum with the use of laminated pole pieces. The permanent magnet has been selected for its stability and long life. The armature moves against a precision-made and hardened knife edge, and is centered between the pole pieces with the aid of three tempered steel springs.

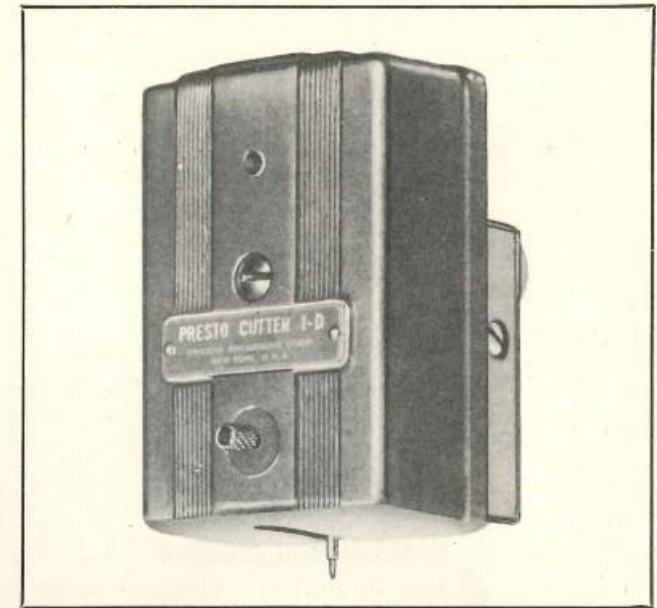

The normal response of the 1-D extends from 50 to 10,000 cycles. Frequencies recorded with this head are of constant amplitude below the cross-over frequency of 500 cycles and of constant velocity above this point for constant input to the recording amplifier at all frequencies within its specified range. In order to obtain 6 db per octave slope below the cross-over point, the 1-D head is used with a simple resistor-capacitor network in series with the amplifier output.

SPECIFICATIONS

Frequency Response: Does not vary from an ideal response curve by more than ± 2 db, 50 to 10,000 cycles.

Distortion: Approximately 3% at full modulation of 112 lines per inch.

Sensitivity: Audio power required for 5.5 cm per sec. stylus velocity at 1000 cps is 0.6 watt.

Recommended Operating Level: + 31 dbm at 1000 cps. 0 dbm = 0.001 watt.

Impedance: Available in 15 or 500 ohms.

Mounting Screws: 1 $\frac{1}{8}$ " centers.

Dimensions: Height 2 $\frac{1}{4}$ "; width, 1 $\frac{5}{8}$ "; depth, 1 $\frac{5}{16}$ ".

Finish: Cover, die cast, satin chrome.

Weight: 10 $\frac{1}{4}$ oz.

Shipping Weight: Approximately 1 lb. (.45 kg.).

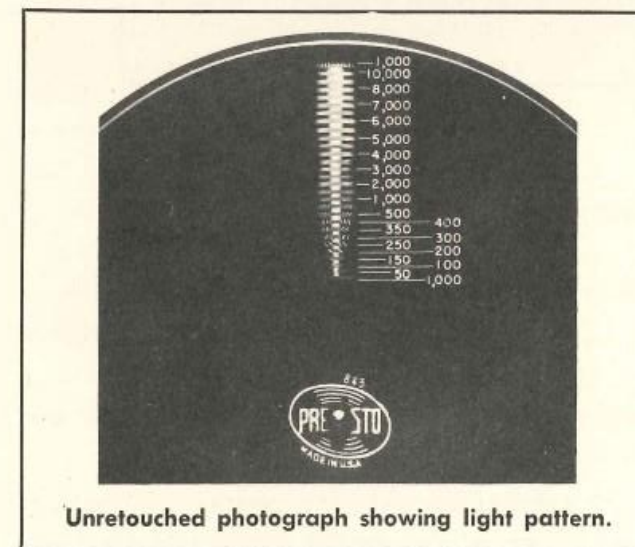

Unretouched photograph showing light pattern.

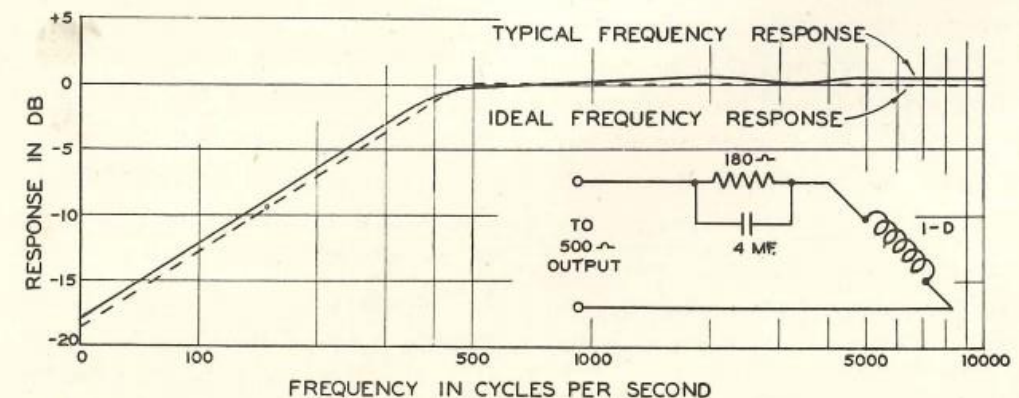

Typical frequency response of the 1-D Cutter vs. ideal frequency response.

PRESTO MODEL "K" RECORDER

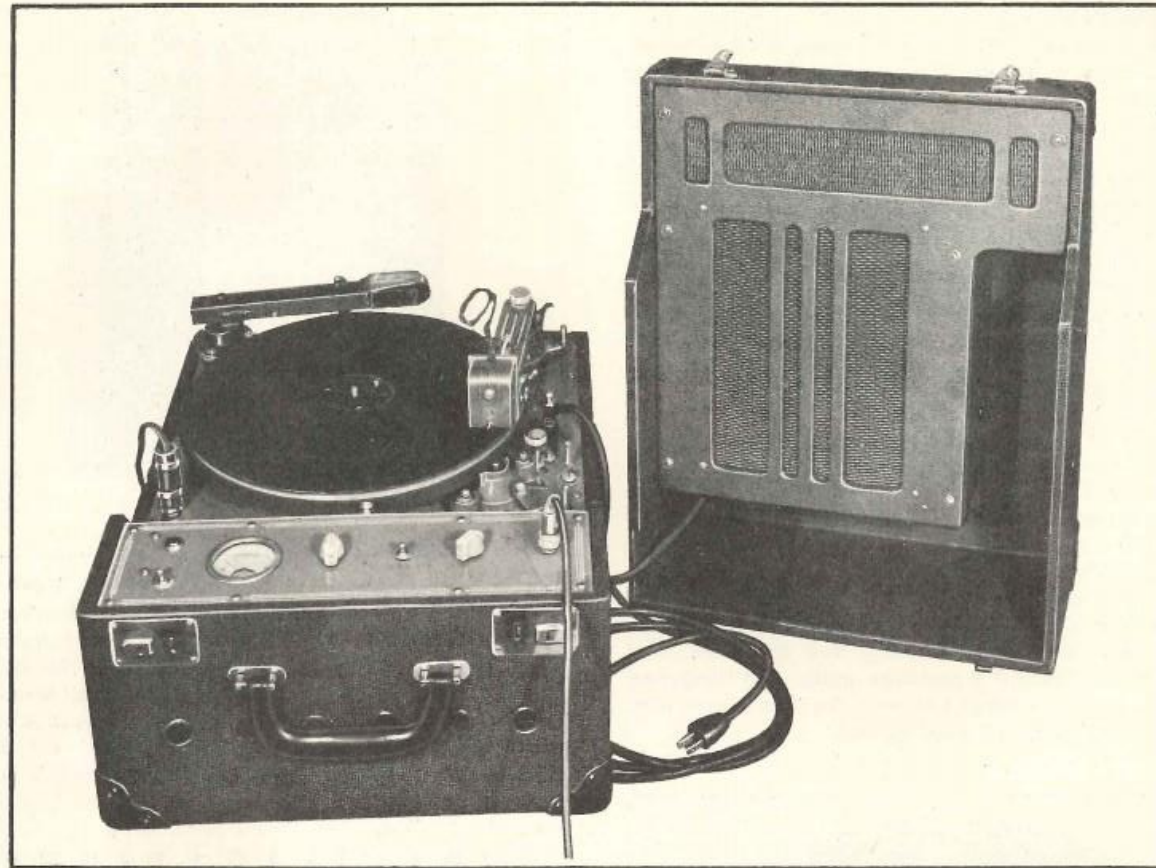

THE Presto model K is a portable sound recorder, record player and public address system complete in a single carrying case. Exceptionally light and compact, it is ideally suited to the needs of sales training and industrial schools, teachers of speech, music and dramatics, as well as professional actors and musicians who require an instrument that can be carried easily and set up for operation in a few minutes time.

The model K records 15 minutes continuously at 33 1/3 RPM on side of a 13 1/4" disc. It may be connected to any home radio set to record complete radio programs. It also makes 6, 8, 10 and 12 inch records, and plays all makes of phonograph records. As a voice amplifying system it will serve audiences of about 500 persons.

Although it is the lowest priced complete Presto recorder, it contains many valuable features of the more expensive instruments such as:

1. A magnetic cutting head and pickup, the design used in the highest grade equipment.
2. A full sized, 7 tube amplifier having push-pull triodes in the power stage.
3. A high frequency equalizer for 33 1/3 RPM recording and a tone control for suppressing needle scratch when commercial records are played.
4. A safety cam lever for lowering the cutting head to prevent accidental damage to sapphire needles.
5. A detachable, dynamic loudspeaker which may be operated at any desired distance from the recorder.
6. A cutter feed mechanism located beneath the turntable where it is protected from dust or accidental damage.
7. Provision for quick change from cutting outside-in to inside out.

8. The exclusive Presto rubber-tired turntable driven directly by a pulley on the motor shaft, a drive system that eliminates rubber pulleys and belts which are subject to rapid wear. Turntable speed may be changed in 5 seconds from 78 to 33 1/3 RPM by removing a brass pulley on the motor shaft.

These features, not found in any other low-

priced recorder enable the user to make high quality recordings, consistently. They simplify the operation of the instrument for non-technical owners and reduce operating costs by preventing spoilage of discs and needles. As a result of its excellent performance, more Presto model K recorders are now used by schools, industrial concerns and in the home than any other recorder in a similar price range.

SPECIFICATIONS

Standard Equipment: The type K-8 recorder consists of a 12" dual speed turntable machined from a heavy metal casting and fitted with a live-rubber tire at the rim, a heavy duty constant speed motor, a magnetic cutting head, cutter feed mechanism, magnetic pickup, five stage recording amplifier and loudspeaker mounted in a reinforced leatherette carrying case with leather corner guards and handle. **Accessories necessary to operate the recorder include microphone and stand, discs and needles which must be ordered separately.**

Frequency Response: Amplifier, without equalization uniform within 2db from 50 to 8,000 cycles. With the high frequency equalizer at maximum setting the response at 6,000 cycles is 20 db higher than the 500 cycle response. With scratch filter at maximum setting the response is down 25 db at 5,000 cycles. Cutting head and pickup response 80 to 5,000 cycles.

Noise Level: Total of all electrical and mechanical noise, originating in equipment, 25-30 db below maximum useful sound level reproduced from recordings.

Speed Accuracy: Within .5%. Regulation within a single revolution is accurate to .3%.

Gain: Amplifier, measured at 1,000 cycles, 110 db.

Controls: Amplifier control panel contains a volume indicator meter, combination high frequency equalizer and tone control, dual volume control, selector switch for recording, playback and public address operation and the microphone receptacle. The turntable chassis contains jacks for connecting the loudspeaker, monitoring headphones for use while recording and a radio set or external pickup.

Tube Complement: First stage 6-SQ-7, second stage 6-SQ-7, third stage 6-SQ-7, fourth stage 6N7, power stage 2-45's P. P., rectifier 1-80.

Cutting Pitch: Feed mechanism cuts 112 lines inside-out or outside-in.

Power Requirements: Standard equipment draws 120 watts on a 110 volt 60 cycle line. Available for other voltages and frequencies at additional cost. See price list.

Finish: Carrying case, dark gray leatherette. Case fittings and metal parts are finished in smooth gray enamel and heavy nickel plate.

Operating Dimensions and Weight: With case closed 19 1/2" x 15 1/2" x 14" (50 x 39 x 36 cm.) weight 46 lbs. (21 kg.).

Shipping Dimensions and Weight: Recorder is packed in a single case measuring 32" x 21" x 17" (81 x 53 x 43 cm.) weighing 69 lbs. (31 kg.). Accessories such as microphone, discs, etc., are shipped in separate cartons.



PRESTO TYPE 9-C RECORDING TURNTABLES

A PORTABLE 12" turntable that records 15 minutes continuously at 33 1/3 RPM on one side of a 13 1/4" disc. It also makes 6", 8", 10" and 12" records at either 78 or 33 1/3 RPM and plays all makes of phonograph records. Its exceptional steadiness, speed accuracy and lack of vibration make it an excellent table for re-recording purposes. The Presto 9-C is recommended as a second turntable to be added to the model K recorder for continuous recording. The chassis can be installed in many home radio sets in place of the ordinary phonograph turntable to provide both recording and playback facilities. It may also be connected to any radio set for recording and playing complete 15 minute programs.

SPECIFICATIONS

Standard Equipment: Consists of a 12" dual speed turntable machined from a heavy metal casting and fitted with a live rubber tire at the rim. The turntable is equipped with a heavy steel shaft which revolves on a single ball bearing at the base of the shaft well. The heavy live rubber tire on the turntable rim is driven by a pulley on the motor shaft. The motor is suspended on rubber grommets to suppress vibration. A single lever operates the motor switch and engages the motor with the turntable. Speed is changed from 78 to 33 1/3 RPM by removing a slip-over pulley on the motor shaft. The cutting mechanism consists of a worm, gear and pinion driven by a fibre worm on the turntable shaft. The table is equipped with a high grade magnetic cutting head and pickup. **Accessories necessary to use the table include recording amplifier, microphone, loudspeaker, discs and needles which must be ordered separately.**

Frequency Response: Cutting head and pickup 80 to 5,000 cycles.

Noise Level: Minus 25-30 db.

Speed Accuracy: Within .5% at both 78 and 33 1/3 RPM. Regulation within a revolution .3%.

Impedances: Cutting head 5 ohms, pickup 2000 ohms.

Amplifier Requirements: Power level required for cutting head plus 16 db. Gain required to produce 0 db level from pickup 40 db. (Ref. .006W).

Cutting Pitch: 112 lines an inch inside-out or outside-in as specified by purchaser.

Power Requirements: Motor draws 30 watts on a 110 volt 60 cycle line. Available for 110 volts, 50 cycles at no additional charge.



Finish: Metal parts gray enamel with nickel trim. Case dark gray leatherette.

Dimensions and Weight: Operating dimensions, case closed. 15 1/4" x 14" x 9 1/4" (38x36x23 cm.), weight 22 1/2 lbs. (10 kg.).

Shipping Dimensions: 32" x 20 1/4" x 12" (81x51x30 cm.), weight 37 1/2 lbs. (17 kg.).

TYPE	DESCRIPTION	PRICE	CODE
9-C	Dual speed turntable chassis only		RIVAT
9-C	Above mounted in 2-C carrying case		REVEL

495 - L 495
 33 1/3 = 165
 Cost 330
 + 10 33
 \$ 363 00

PRESTO 64-A TRANSCRIPTION TURNTABLE

THE Presto 64-A transcription turntable offers the following features which are of major importance to the owner and operator: Unusual mechanical simplicity . . . low mechanical disturbance . . . maximum speed accuracy . . . extreme ruggedness for long continuous operation . . . instantaneous selection of desired speed . . . and no requirements for mechanical adjustments.

This transcription turntable is directly gear driven and employs two separate motors, one for 33 1/3, and the other for 78.26 rpm. There is no friction device of any kind in the mechanism and no mechanical shift is required to change speeds. To select 33 1/3 rpm, 78 rpm or "off," the operator merely throws a three position switch. These changes may be made as rapidly as desired while the turntable is in motion with no damage to the mechanism. Only one motor at a time is in operation. The transmission "over runs" the motor which is not turning and thus does not carry it along in rotation although the stationary motor is never disengaged from the mechanism.

The transmission is unusually simple in design but so precisely constructed that mechanical disturbances are at a minimum. Such disturbances are reduced to 50 db below program level by a mechanical filter placed between the gear box and the turntable. More than ample power is provided by the 1800 rpm, 110 volt, single phase, synchronous motors, thus reducing the total speed variation to zero.

The Presto 64-A transcription turntable does not at this time include a reproducer. If a reproducer of any manu-

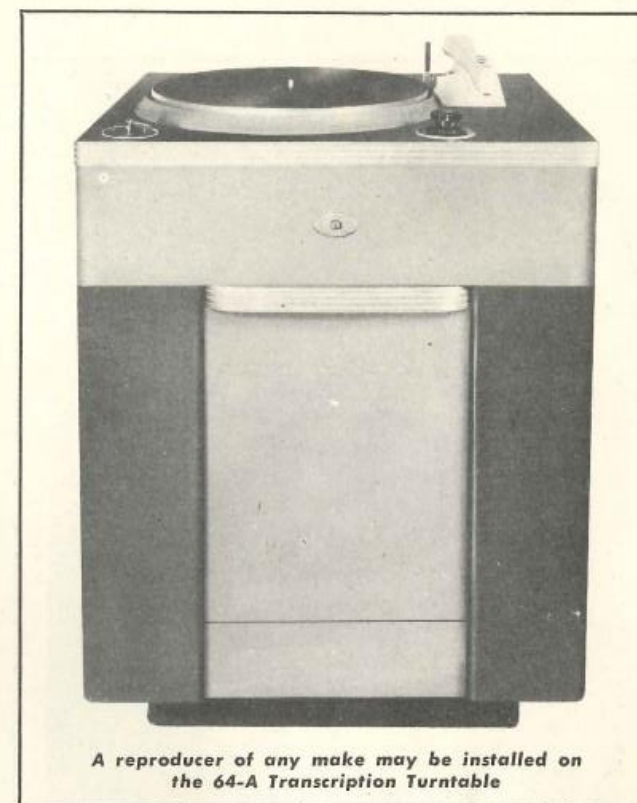

A reproducer of any make may be installed on the 64-A Transcription Turntable

facture is to be installed by Presto, the purchaser of the turntable should order such reproducer from its manufacturer with instructions that it is to be shipped to Presto with the purchase order number of the Presto Turntable indicated.

SPECIFICATIONS

Standard Equipment: The 64-A transcription turntable includes the electro-mechanical gear drive, turntable and cabinet. A **reproducer** and **network** is not included.

Speed Accuracy: No deviation from 33 1/3 and 78.26 rpm.

Noise Level: Mechanical noise originating in the equipment over 50 db below program level.

Power Requirements: Approximately 75 watts from a 115 volt, 60 cycle line. Motors are of the 1800 rpm synchronous type and are available for other voltages and frequencies at additional cost.

Mounting: Turntable and gear drive mounted in heavy wood cabinet with inlaid linoleum top is 24 x 24 x 33 inches (61 x 61 x 84 cm).

Shipping Dimensions and Weight: The 64-A is packed for shipment in one case measuring 31 x 31 x 37 inches (79 x 79 x 94 cm) and weighs 266 lbs (120 kg).

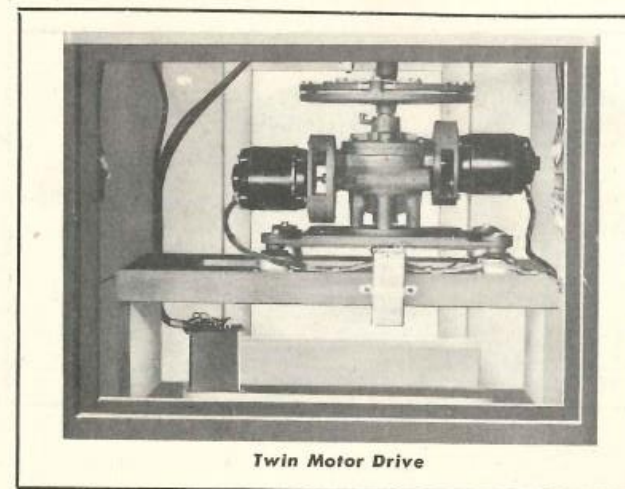

Twin Motor Drive

2 495 00

N. 420.75

PRESTO TYPE 62-A TRANSCRIPTION TURNTABLE

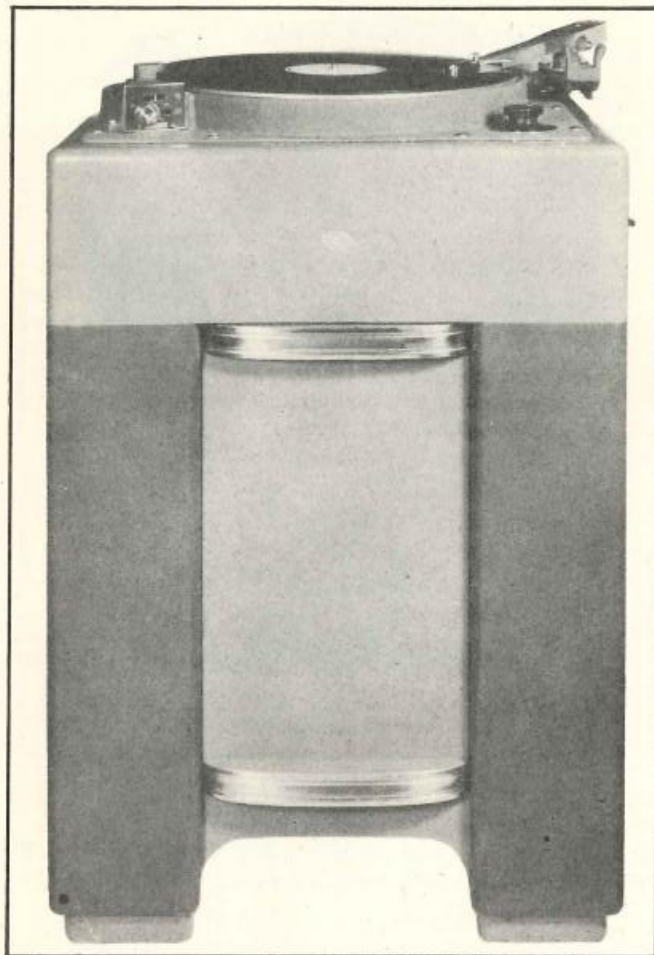

BROADCASTING stations, recording studios, and many others have become familiar with the Presto 62-A transcription turntable and know of its long record for dependable performance. The operation of the equipment is extremely simple. The motor and rim-driven turntable are the only moving parts and maintenance usually consists only in replacing the rubber turntable tire.

Speed regulation and mechanical noise are well within broadcast station limits although not equal to the performance of Presto directly gear driven turntables.

The lateral reproducer included with the 62-A is of a recently improved type. Frequently response and tracking of the stylus is such that excellent results are obtained from modern lateral transcriptions.

The complete 62-A is composed of the 10-A chassis (see page 27), and 3-A cabinet and the 152-A reproducer and compensator. The combination of the 10-A chassis mounted in the 3-A cabinet but without the reproducer is designated as the Presto 63-A.

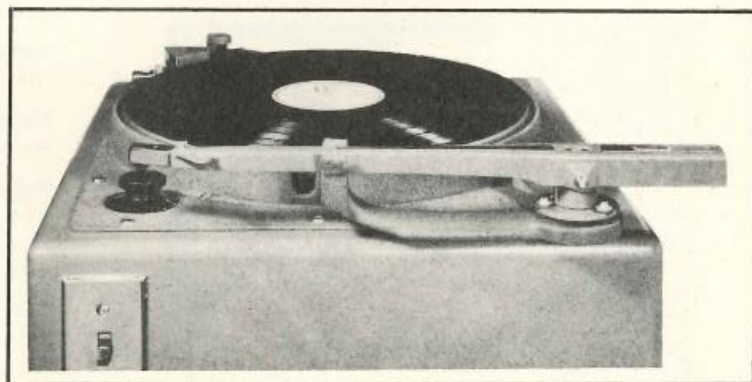

The 152-A lateral reproducer is of the magnetic type having a response essentially uniform between 50 and 10,000 cps when used with shellac or vinylite pressings. The compensator has four positions to select the proper response for: (1) flat recordings, (2) the usual 78 rpm recording characteristic, (3) the NAB recording characteristic, and (4) a sharp cut-off at 4,000 cycles for use with badly worn discs.

SPECIFICATIONS

Standard Equipment: The complete 62-A transcription turntable includes the following parts and accessories: type 10-A turntable chassis mounted in 3-B cabinet, equipped with 152-A lateral magnetic reproducer with special replaceable sapphire stylus and compensating network.

Frequency Response: Uniform from 50 to 10,000 cycles when reproducing standard makes of transcriptions.

Noise Level: Total of all sound, originating in equipment over 45 db below maximum useful sound level.

Reproducing Stylus: Sapphire, hand lapped to fit standard groove dimensions. Needle pressure $1\frac{1}{4}$ oz.

Output Level: Amplification of 65 db is required to produce a power output of .006 W when reproducing from standard frequency record.

Output Impedance: Standard equipment is designed to work into impedance of 500 ohms. Type 505-A matching transformer required for 50, 200 or 250 ohm input.

Speed Regulation: Speed accuracy of .5% is maintained at both 78 and $33\frac{1}{3}$ RPM. Speed regulation within a single revolution is accurate to .25%.

Controls: A speed change lever, a motor mercury switch and a four position selector switch for compensating network. 1st Pos. Flat response; 2nd Pos. Roll off on high end to compensate for pre-emphasis as used by major record manufacturers; 3rd Pos. Complements N.A.B. $33\frac{1}{3}$ recording; 4th Pos. Sharp cutoff at 4,000 cycles for use with worn commercial discs.

Operating Dimensions: Overall clearances required for installation is shown in Figure below.

Shipping Dimensions and Weight: Packed for shipment in a case 27"x25"x40" (68x63x101 cm), weight 95 lbs., (43 kg.), and one carton measuring 26"x11"x11" (63x28x28 cm.), weight 10 lbs. (4.5 kg.).

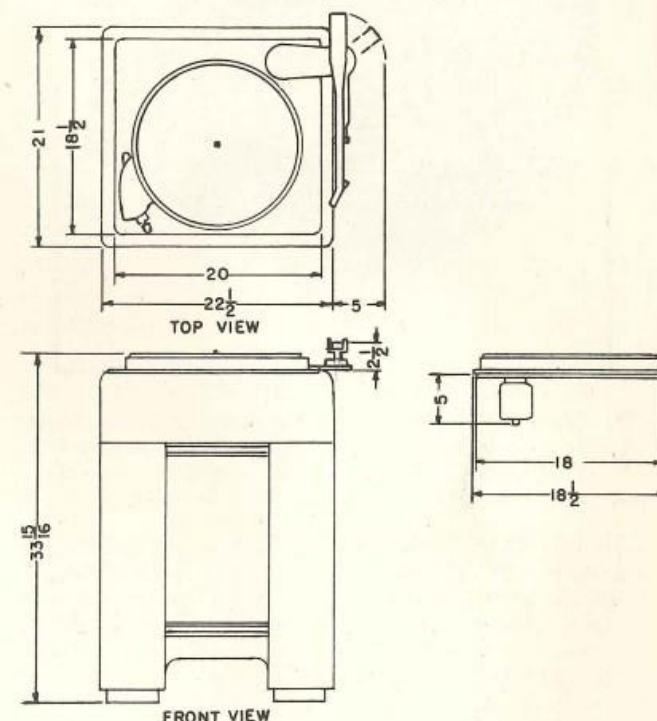

PRESTO Model "L" Transcription Playback

(Federal excise tax applies to this unit.)



THIS equipment is designed for radio stations, advertising agencies and program producers who demonstrate recorded programs at the offices of prospective clients.

Salesmen who use the Model L Playback will particularly appreciate its attractive, workmanlike appearance, its small size and light weight which make it extremely easy to carry, its simplicity which makes it possible to set up for operation within a few seconds and the remarkably clear, wide range reproduction . . . far superior to that ordinarily expected from portable equipment.

The Model L Playback was developed to meet an insistent demand among the larger broadcasting stations and agencies for "something better" in portable reproducing equipment. Those who use the Model L Playback in connection with important sales of station time and programs will consider its exceptional performance well worth its cost.

Standard Equipment: The Model L Playback consists of a 12" dual speed rim-driven recording turntable, a high quality 16" pickup on a swivel mounting which folds into the case when not in use, a four stage amplifier and an 8" loudspeaker, mounted in a single carrying case. The speaker mounted in the case cover is equipped with a 20' extension cable.

Frequency Response: Overall 80 to 7500 cycles.

MODEL	DESCRIPTION	PRICE	CODE
L-2	Portable transcription playback		ELBEX

NOTE: Available for 110 volts 50 cycles at no additional charge. For changes necessary to operate on 110 volt 50/60 cycles, add \$20.00; for 110 volts 25 cycles, add \$50.00.

Reproducer: Lateral magnetic type, needle pressure 1 1/4 oz. Permanent stylus included.

Power Output: Amplifier 4.5 watts undistorted.

Output Impedance: For external speaker, 8 ohms.

Speed Accuracy: Within .5%. Regulation within a single revolution. .3% at both 78 and 33 1/3 RPM.

Gain: Amplifier 70 db.

Controls: Amplifier control panel contains, tone control having a range suitable for adjusting response for all makes of lateral recordings, volume control and power switches.

Tube Complement: Amplifier 1st stage 6SF5, 2nd stage 6SF5, 3rd stage 6N7, power stage 45's PP, Rectifier '80.

Power Requirements: Draws 110 watts on a 110 volt 60 cycle line. Available for other frequencies at added cost. See price list. Converter required for direct current operation.

Finish: Carrying case covered in gray airplane luggage cloth. Metal parts finished in smooth gray enamel with nickel trim.

Operating Dimensions and Weight: With case closed 19 1/2" x 15 1/2" x 14" (50 x 39 x 36 cm.), weight 46 lbs. (21 kg.).

Shipping Dimensions' Weight: Packed for shipment in a single case measuring 32" x 21" x 17" (81 x 53 x 43 cm.), weighing 69 lbs. (31 kg.).

PRESTO Type 10-A Turntable

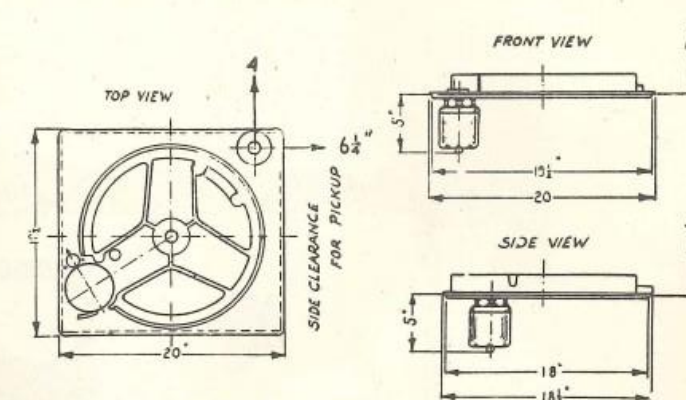
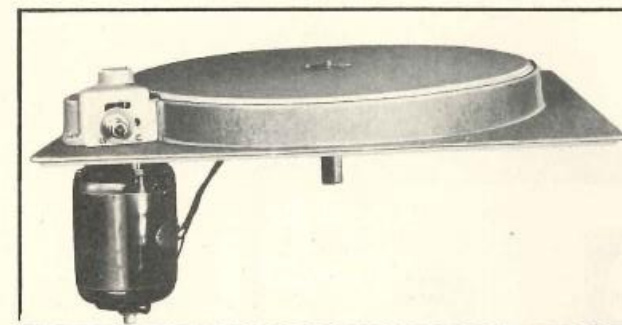

Mounting dimensions 10-A table

NATURAL reproduction of electrical transcriptions requires a turntable which is absolutely steady in speed and exceptionally free of mechanical vibration. Practical operating conditions in broadcasting stations call for a table which may be operated 18 hours daily over long periods of time without adjustment. The Presto 10-A turntable is designed to meet these requirements.

The 10-A table forms a part of the Presto 62-A and 63-A transcription turntables. The chassis only is offered as a replacement unit for stations having satisfactory reproducing pickups mounted on worn or inadequate turntables. The 10-A chassis can be mounted in most cabinets without disturbing the pickups or controls.

The mechanical design of the 10-A table is extremely simple. There are but 2 moving parts. The table consists of a metal platter to which a live rubber tire is fitted. This assembly is machined to perfect roundness and dynamic balance. A steel step pulley on the motor shaft drives against the rubber rim of the table. Speed is changed instantly by moving the motor carriage to engage either section of the drive pulley. Maintenance consists of oiling at 90 day intervals, occasional adjustment of the drive pressure and replacement of the tire once yearly.

The 10-A table is used and recommended by leading radio stations and transcription makers for playing both vertical and lateral recordings.

SPECIFICATIONS

Standard Equipment: Consists of the turntable and bearing, motor and drive system completely assembled on a cast metal base ready for operation.

Speed Regulation: Speed accuracy of .5% is maintained at both 78 and 33 1/3 RPM. Speed regulation within a single revolution is accurate to .25%.

Noise Level: Total of all sound originating in table over 40 db below maximum program level.

Size: Turntable diameter 16".

Finish: Gray enamel.

Power Requirements: Synchronous motor draws 50 watts on a 110 volt 60 cycle line. Motors available for other voltages and frequencies at additional cost.

Operating Dimensions: See drawings.

Shipping Dimensions and Weight: One case measuring 31"x24"x15" (79x61x38 cm.), weighing 55 lbs. (30 kg.).

TYPE	DESCRIPTION	PRICE	CODE
10-A	Turntable chassis		TERSE
127-A	Rubber tire for replacement		BAJRE

NOTE: Add \$10.00 for adapting equipment to operate on 220 volts 60 cycles, 110 volts or 220/240 volts 50 cycles. Add \$30.00 for table to operate on 25 cycle supply.

Presto Type 90-A Recording Amplifier



THE Presto 90-A recording amplifier is a portable console containing all the facilities necessary for operation on remote assignments, but with an overall performance found only in high fidelity studio equipment.

The 90-A consists of three preamplifiers, mixer, master gain control and recording amplifier.

A selector switch provides: A flat response, 30 to 15,000 cps \pm 1 db—NAB 33 1/3 RPM recording — playback characteristic complementing NAB recording — and, the present day 78 RPM recording characteristic. The flat response can be modified by variable bass and treble controls giving emphasis up to 20 db at 100 and 7,500 cycles per second or 20 db de-emphasis at 7,200 cycles per second.

Noise is 60 db below recording level. Distortion at maximum output is less than 1.5%.

The use of input and output selectors makes the 90-A amplifier unusually flexible. It permits combining the signals of three microphones or of two microphones and either one of two pickups. By using the "Line" position, recordings can be made from an incoming program line. The output selector has playback (public address), continuous recording and simultaneous recording positions. While recording, the line jack provides a monitoring outlet or permits feeding a program line at the correct level.

The recording level is monitored by means of a Weston Type 30 VU indicator with illuminated scale and its closely controlled electrical and dynamic characteristics make it an ideal volume indicator for recording.

DETAILED PERFORMANCE SPECIFICATIONS

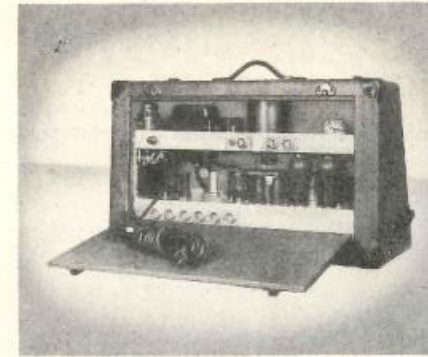

Input (source) Impedance:

Microphone No. 1	50, 200 and 500 ohms	200 ohms standard impedance. Pre-wired at factory to customer's specifications.
Microphone No. 2	50, 200 and 500 ohms	
Microphone No. 3	50, 200 and 500 ohms	
Pickup No. 1	50, 200 and 500 ohms	
Pickup No. 2	50, 200 and 500 ohms	
Line	500 ohms	

Output (load) Impedance:

Speaker	500 ohms
Outgoing Line	balanced 600 ohms
Cutter No. 1	500 ohms
Cutter No. 2	500 ohms

Output (source) Impedance:

Outgoing Line	600 ohms
---------------	----------

Gain:

Microphone/pickup to cutter/speaker (maximum power gain)	115 db \pm 3 db
Line Input to cutter/speaker (maximum power gain)	80 db \pm 3 db.

Maximum Input Level:

Microphone or pickup	approx.—44 dbm*
Line input	approx.—10 dbm**

(0 dbm = 0.001 watt)

* at overload of preamplifier section.

** in order to maintain smooth control it is not recommended to go above approximately—27 dbm.

Signal-to-Noise Ratio (at recording level):

All microphone channels and line channel at 80 db gain	at least 60 db.
--	-----------------

Volume Indicator Calibration:

0 VU corresponds to:	
+ 31 dbm at 1,000 cycles into cutting head.	
+ 10 dbm at 1,000 cycles into line output.	

Output Level and Distortion:

Speaker or cutter (maximum)	10 watts
Distortion at maximum output (50-7500 cycles) less than	1.5%

Frequency Response:

All microphone channels and line (input channel)	30-15,000 cps \pm 1 db
--	--------------------------

Panel Controls and Instruments:

Three input gain controls and a master gain control are step type controls (1.5 db per step and infinity).

INPUT No. 3 SELECTOR permits the following combinations:

- P.U. No. 1 Position: 2 Microphones and Pickup No. 1
- P.U. No. 2 Position: 2 Microphones and Pickup No. 2
- Mic No. 3 Position: 3 Microphones
- Line Position: Line input only

EQUILIZATION selector:

NORMAL Position: Response flat with both controls at zero.

NAB LAT. REC. Position: NAB recording characteristics for lateral transcriptions. Low frequency response below cross-over is determined by recording head characteristic in this region. Tolerance \pm 2 db.

78 LAT. REC. Position: Frequency characteristic rising from approximately 1000 cps on to about 10 db at 10,000 cps. Tolerance \pm 2 db.

LAT. PLAYBACK Position: Characteristic complementary to NAB recording characteristic. Tolerance (80-10,000 cps) \pm 2 db.

LOW FREQUENCY EQUALIZER CONTROL:

Maximum low frequency emphasis at approximately 100 cps

20 db

HIGH FREQUENCY EQUALIZER CONTROL:

Maximum high frequency emphasis at approximately 7500 cps

20 db

Maximum high frequency de-emphasis at approximately 7200 cps

20 db

OUTPUT Selector:

SPEAKER position; Public address and playback.

REC. CONTIN. position: Continuous recording with one cutting head and simultaneous monitoring.

REC. SIMUL. position: Simultaneous recording with both cutters and simultaneous monitoring.

CUTTER SELECTOR

POWER SWITCH

Power Input:

117 volts, 50/60 cps	135 watts
----------------------	-----------

Tube Complement:

6 type 6SJ7's, 1 type 6SQ7, 1 type 6SN7-GT, 2 type 6L6-G, 1 type 5U4G

Mounting:

Reinforced carrying case covered in dark grey leatherette, equipped with 4 nickel plated catches and a leather handle

Operating Dimensions and Weight:

24" x 13" x 14" (60 x 33 x 35 cm.). Weight 53 lbs. (24 kg.).

Shipping Dimensions and Weight:

30" x 17" x 18" (76 x 43 x 45 cm.). Weight 94 lbs. 42 kg.).

Presto Type 85-A, B & E Recording Amplifiers

THESE amplifiers form a part of the Presto Models A, and B recorders. The fundamental amplifier circuit is the same in each type. It consists of three stages of push-pull amplification and a built-in power supply which has sufficient capacity to provide power to the 40-A and B preamplifiers and plate power for the 50-A and B radio tuners.

Careful assembly and the use of the highest quality parts throughout make the noise level and harmonic distortion exceptionally low. The power stage and output transformer are designed specifically to match the load characteristics of the Presto I-D cutting head.

The 85-B amplifier is designed to mount in a standard relay rack and connections are brought out to a terminal strip at the rear of the chassis. The 85-A portable model includes an 8" monitor loud speaker and receptacles on the panel for connecting two turntables, a preamplifier and radio tuner. The 85-E is identical with the 85-A except that it includes a manually operated high frequency equalizer for 33 1/3 RPM recording.

Frequency Response: Flat from 30 to 15,000 cycles.

Gain: 90 db.

Power Output: 10 watts.

Impedances: Input and output, 500 ohms.

Distortion: Less than 1% at maximum level required for I-C cutting head.

Controls: Master volume control, selector switch for public address, microphone recording, play-back, radio recording and radio playing, switch for changing to either of two tables for continuous recording. Type 85-E has in addition a switch for selecting the peak frequency of the equalizer and a potentiometer for controlling the degree of equalization.

Tube Complement: 1st stage two 6-J-7's; 2nd stage two 6-S-J-7's; 3rd stage two 6-L-6-G's push-pull; rectifier one 5Z3.

Power Requirements: Draws 120 watts on 110 volt 50/60 cycle line. Available for 25 cycle supply at \$25.00 additional.

Finish: Case, gray leatherette; panel, black enamel.

Operating Dimensions and Weight: 85-A and E amplifiers, case closed, 17"x13"x18 1/2" (43x33x47 cm.). Weight 53 lbs. (24 kg.), 85-B panel measures 10 1/2"x19", (27 x 48 cm.).

Shipping Dimensions and Weight: 30"x22"x24" (76x56x61 cm.). Weight 98 lbs. (44 kg.).

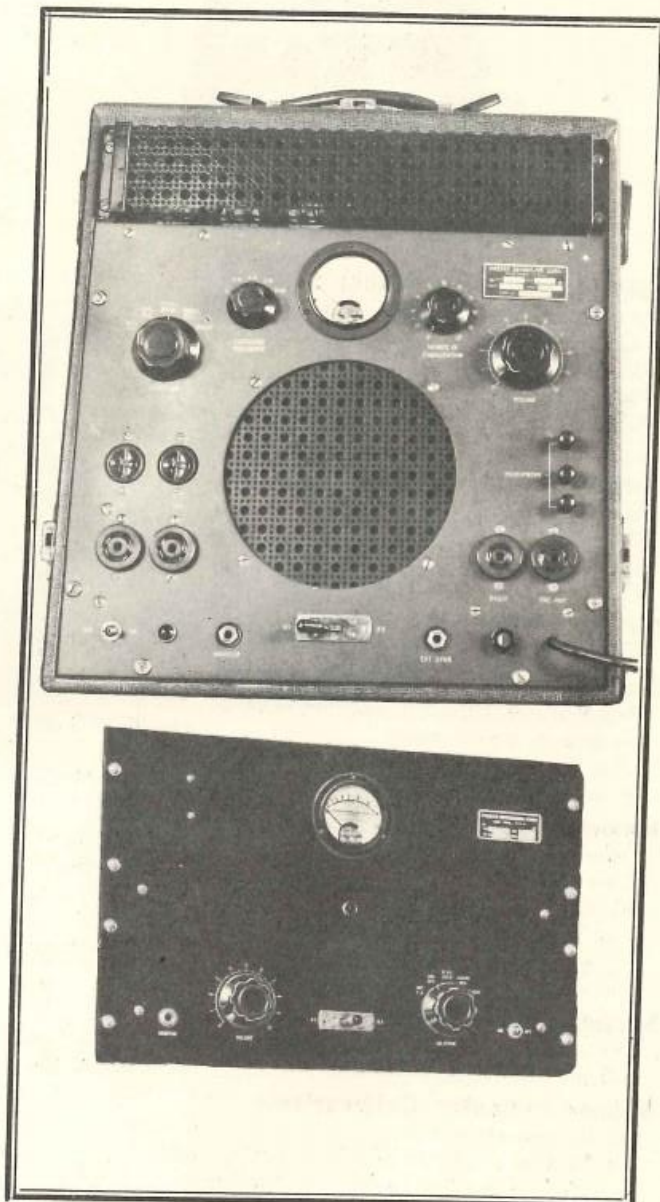

TYPE	DESCRIPTION	PRICE	CODE
85-A	Portable recording amplifier		RECAM
85-E	Portable recording amplifier		REQUA
85-B	Rack mounting amplifier		RACER

Presto Type 87-A and 87-B Recording Amplifiers

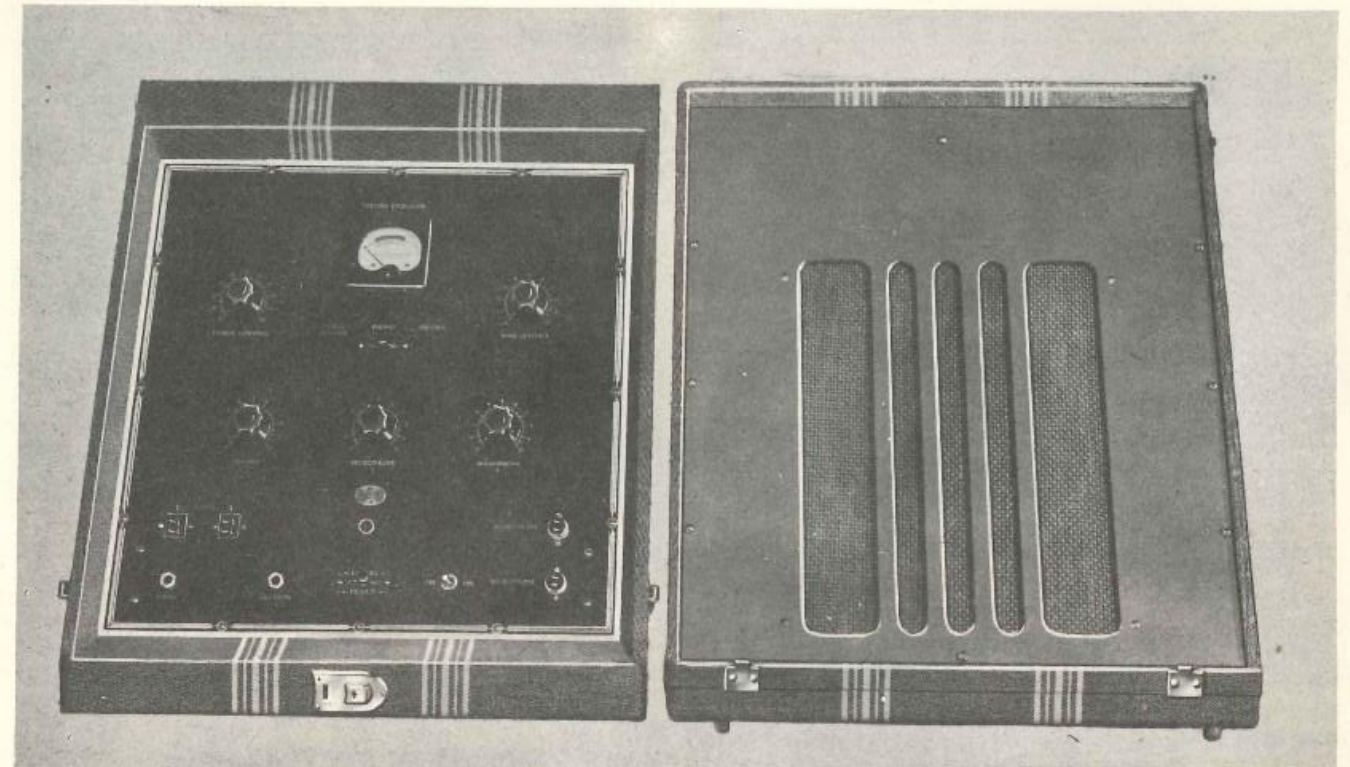

THESE amplifiers form a part of the Presto models F and Y recorders. Their design includes all of the facilities necessary for making and reproducing high quality recordings outside of the studio. The carrying case is conveniently portable and is divided diagonally to mount the amplifier in one side and a full size dynamic loud-

speaker in the other. Used in conjunction with a suitable microphone this unit also forms an excellent portable sound amplifying system for serving audiences up to 500 persons. The 87-A amplifier is designed for use with high impedance microphones. The 87-B amplifier contains input transformers for use with low impedance microphones.

SPECIFICATIONS

Frequency Response: Amplifier, adjusted for flat response, 30 to 10,000 cycles. Turned to the right the treble control produces a maximum peak of 17 db at 6,500 cycles. Turned to the left it acts as a scratch filter giving a maximum attenuation of 20 db at 5,000 cycles. The bass control produces a maximum peak of 20 db at 100 cycles.

Gain: Adjusted for flat response, 115 db.

Power Output: 10 watts.

Distortion: Less than 1% at maximum level required for cutting head.

Impedances: The 87-A amplifier, microphone inputs 100,000 ohms. Line input jack, 500 ohms, output, 8 ohms. The 87-B amplifier, microphone inputs, 50, 200 or 500 ohms, as specified by purchaser, line input jack, 500 ohms, output, 8 ohms.

Controls: Two microphone input gain controls, playback gain control and continuously variable treble and bass equalizer controls, a switch for changing instantly between cutting heads and pickups (when two turntables are used) and a selector switch which connects the amplifier for recording, playback or public address

operation. Amplifier panel also contains a volume indicator meter, telephone line input jack, monitor jack, two turntable receptacles, two microphone receptacles, and a power switch.

Tube Complement: First stage 2 type 6SJ7's; Radio stage, 1 type 6SJ7; 2nd and 3rd stage 1 type 6SL7-GT; 4th stage (phase inverter) 1 type 6SN7-GT; power stage 2 type 2A3's push-pull, and rectifier 5Z3.

Power Requirements: Draws 120 watts on a 110 volt 50/60 cycle line. Available for 220/240 volts at no additional cost.

Loud Speaker: 10", permanent magnet, dynamic with enclosed baffle.

Mounting: Reinforced carrying case covered in dark gray leatherette, equipped with chromium plated locks and leather handles. Panel, gray enamel.

Operating Dimensions and Weight: Amplifier, case closed 23 1/2" x 12" x 20" (60x31x51 cm.). Weight 57 lbs. (26 kg.)

Shipping Dimensions and Weight: One case measuring 35 1/2" x 26" x 16" (90x66x41 cm.). Weight 78 lbs. (35 kg.).

TYPE	DESCRIPTION	PRICE	CODE
87-A	Recording Amplifier		RUBER
87-B	Recording Amplifier		RUTAL

Presto Type 92-A Recording Amplifier



Front View

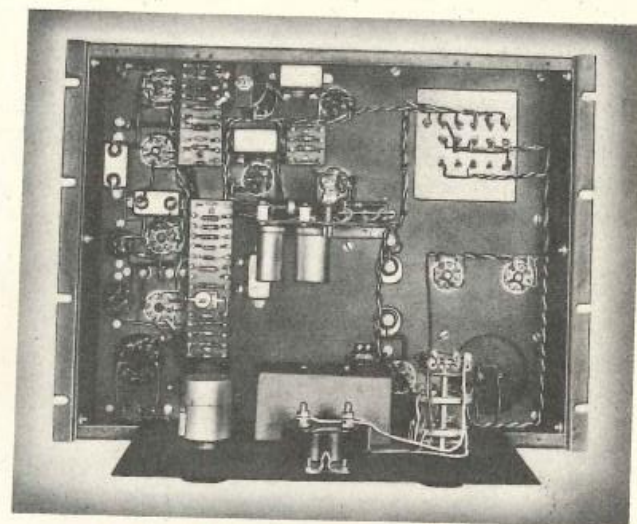

Front View, Panel Removed

THE Presto 92-A amplifier has been developed from the well known model 88-A which has proven so satisfactory as a recording amplifier. The 92-A has a vertically mounted chassis giving access to the tubes from the rear of the relay rack. The front panel of the 92-A is removable while the amplifier remains in the rack, giving access to circuits, resistors, capacitors, etc.

One meter and a selector switch serve to indicate, vari-

ously, output level of the amplifier and plate currents of each of the tubes. Four push-buttons select any of the following recording characteristics: Flat response, 20-17,000 CPS; 78 RPM lateral; NAB lateral; and NAB vertical.

The output stage is unusual having four 807's in push-pull parallel, and provides ample peak power at low distortion.

The frequency response of 20 to 17,000 cps within 1 db exceeds present frequency modulation standards.

SPECIFICATIONS

Frequency Response: Push buttons (left to right): 1—20-17,000 cps within 1 db; position 2—complements 78 RPM lateral playback system having preemphasis as used by many recording studios; position 3—complements NAB lateral playback system; position 4—complements NAB vertical playback system.

Impedances: Input either 500 ohms or 15,000 ohms for bridging as specified by purchaser. Output 500, 250, 15 or 6 ohms as specified by purchaser.

Gain: For 500 ohm input; 83 db. For 15,000 ohm input bridging a 500 ohm line, 68 db.

Power Output: 60 watts.

Distortion: Less than 1 1/2% at 50 watts output.

Noise Level: Better than 60 db below level required for recording using the Presto I-D cutter.

Controls: A step-type gain control; a push button switch to change frequency response; and, a selector switch to measure output level (at 1000 cps) and plate currents of each tube. The meter is not used for monitoring purposes.

Power Supply: Built-in.

Tube Complement: 1 type 6SF5, 1 type 6SN7GT, 2 type 6SJ7, 4 type 807, 2 type 5R4GY and 1 OD3/VR150.

Power Requirements: Draws 190 watts on 117 volts 50/60 cycle line. Available for other voltages and frequencies at additional cost.

Finish: Panel, two-tone gray enamel.

Operating Dimensions: The amplifier and power supply are mounted on a 14" x 19" (36 x 48 cm.) relay rack panel. Depth behind panel is 10" (25 cm.). Weight 84 lbs. (38 kg.).

Shipping Dimensions: 17" x 25" x 13" (43 x 63 x 33 cm.). Weight 105 lbs. (47 kg.).

Presto 89-A Amplifier

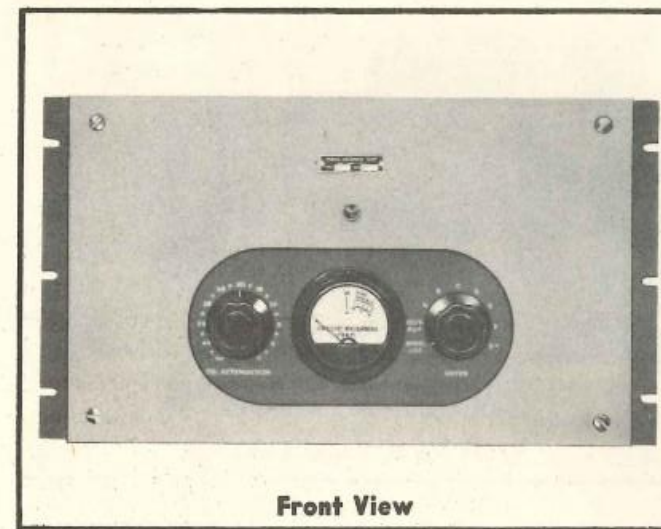

Front View

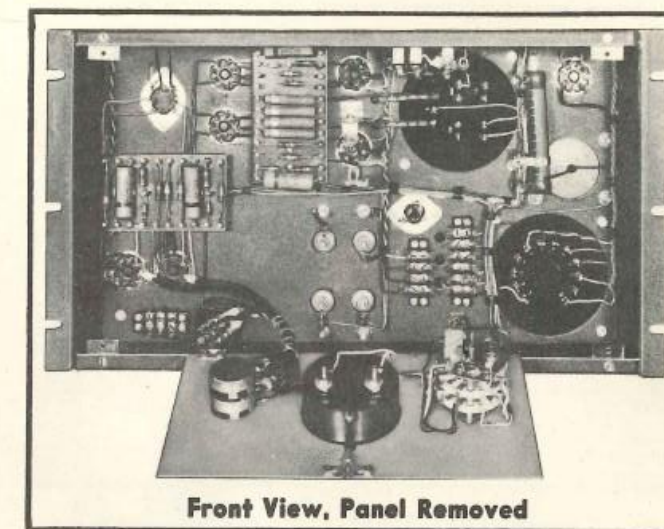

Front View, Panel Removed

DESIGNED for recording, playback and monitoring, the Presto 89-A amplifier embodies the best in components, workmanship and design. Special attention has been given to circuit design to assure low distortion and wide range at full output.

A heavy gauge, vertically mounted chassis with removable front panel gives access to all components without removing the amplifier from the rack.

The circuit consists of three push-pull stages, resistance coupled, with a balanced feed-back loop

from the plates of the output tubes to cathodes of the second stage.

A meter and selector switch is provided which indicates the output of the amplifier at +31 dbm at 1000 cycles and the tube currents of all three stages.

All connections are made to terminal strips inside the chassis so that access to these connections may be had by simply removing the panel while the amplifier is in the rack. Convenient terminals for pre-amplifier power supply are also provided.

SPECIFICATIONS

Response: Uniform within 1 1/2 db from 30 — 15,000 cps., up to full output.

Power Output: 25 watts at rated load impedance.

Gain: 90 db direct, and 75 db with bridging input.

Noise: —30 dbm.

Input Impedance: 500/600 ohms. 250 or 50 ohms may be had on request. Bridging input primary is 15,000 ohms.

Output Impedance: Transformer has two tapped balanced windings for operation into 500, 250, 15 or 8 ohms. Operation into widely varying load impedances produces no change in response or distortion at normal operating levels.

Input Level: For driving Presto 1D cutting head input level should be —4 dbm max. to —59 dbm min.

Distortion: At normal operating levels distortion is only 1/2 of 1%. At a 22 watt (+43.5 dbm) level distortion is less than 3% between 30 and 10,000 cps.

Tube Complement: 4-6SJ7's, 2-807's, 1-5R4GY.

Power Requirements: 120 watts, 115 volts at 50/60 cycles. Power transformer tapped from 100 to 130 volts.

Dimensions: Panel 19" x 10 1/2". Packed for shipping 21" x 12 1/2" x 11".

Weight: Packed for shipping, 50 lbs.

The Presto 41-A Limiter

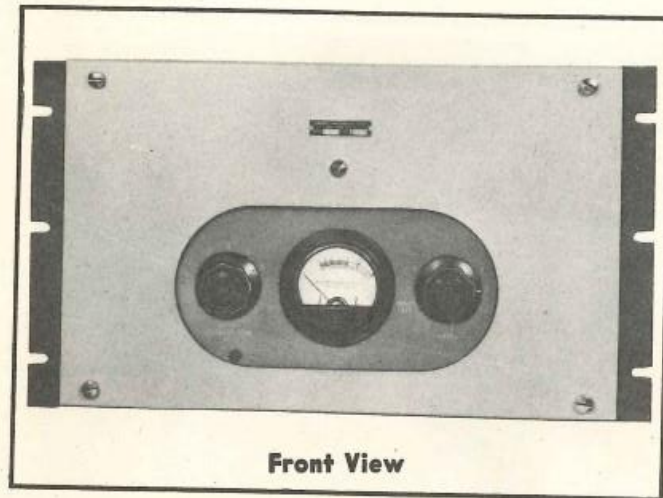

Front View

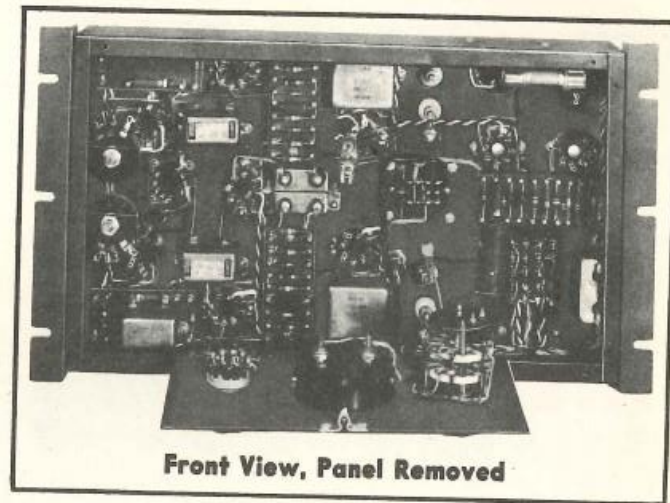

Front View, Panel Removed

THE use of the Presto 41-A Limiter to reduce undesirable peaks permits a considerable increase in average program level and a better signal to noise ratio.

The 41-A is essentially a line amplifier with an automatic gain control circuit. The amplifier input-output characteristic is linear up to a certain definite output level at which any further increase in input will cause no appreciable change in output level. The attack time is less than one millisecond and the recovery time may be varied from 2/10 seconds to one second. The amount of limiting is controlled by adjusting the average program level fed into the 41-A.

SPECIFICATIONS

Frequency Response: Uniform within 1½ db from 30 to 15000 cps.

Gain: 60 db.

Noise: Less than -47 dbm.

Output Level: +20 dbm (Output level at which limiting starts).

Distortion: Not more than 1% RMS for any frequency between 50 and 10,000 cycles at any output level up to the limiting point.

A regulated power supply is an integral part of the 41-A providing constant value high voltage to the amplifier with AC line voltage variations between 100 and 130 volts.

A meter and selector switch are provided to indicate the amount of limiting taking place and to also show the current readings of all amplifier tubes.

Provision is made for connecting an external compression indicator meter at a control desk or other remote point to permit central monitoring.

Chassis is for vertical mounting and a removable front panel gives access to all circuits without dismounting the amplifier from the rack.

Input and Output Impedances: 50, 200 or 500 ohms. Normally connected for 500 ohms.

Power Requirements: Draws 70 watts from 115 volt 50/60 cycle line.

Tubes: 2-6L7's, 2-6SJ7's, 2-6J5's, 1-6SL7GT, 1-2A3, 1-5R4GY, 1-OD3/VR150.

Dimensions: Panel 19" x 10½". Packed for shipping, 21" x 12½" x 10".

Weight: Packed for shipping, 42 lbs.

Presto 39-A and 39-B Preamplifier

THE Presto 39-A or 39-B preamplifier is a three channel mixing preamplifier designed to drive Presto recording amplifiers. Individual amplification in each channel is provided and electronic mixing is done at a sufficiently high level to eliminate noise from the volume controls. These controls are high quality step-type pads assuring quiet, trouble-free operation.

The Presto 39-A is an extremely compact portable amplifier weighing about twenty pounds. Its power supply is obtained from the recording amplifier or a separate source. Cords and connectors are provided for this purpose.

The 39-B is constructed with a 19" panel for standard relay rack mounting. Switches to select 30/50 or 200 ohms are provided. Power is obtained from the recording amplifier or from a separate source.

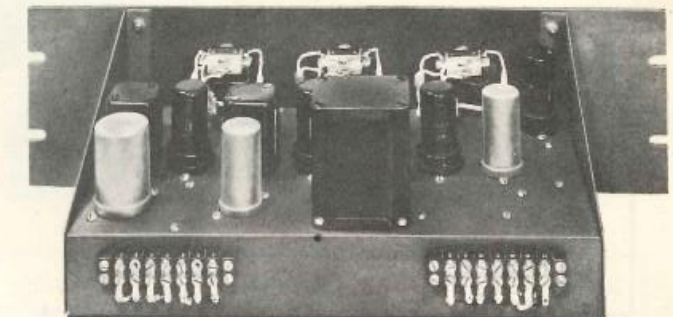
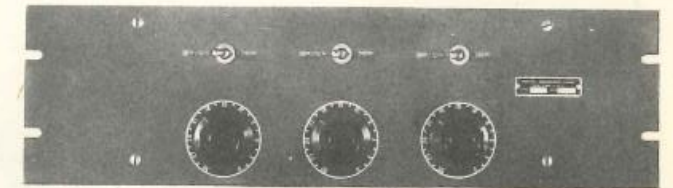

39-B Preamplifier



39-A Preamplifier

SPECIFICATIONS

Frequency Response: ± 0.75 db 30-15,000 cps.

Impedances: 39-A input wired for either 50, 200 or 500 ohms; 39-B input wired for 30/50 and 200 ohms; 39 A/B output wired for either 50, 200 or 500 ohms. (500 ohms standard.)

Gain: 43 db through any channel.

Noise: 72 dbm (0 dbm = 0.001 watt).

Power Supply Required: 250-300 volts at 8 ma; 6.3 volts at 1.2 amps.

Tube Complement: 3 types 6SJ7 and 1 type 6J5.

Presto Type 160-A and 160-B Automatic Equalizers

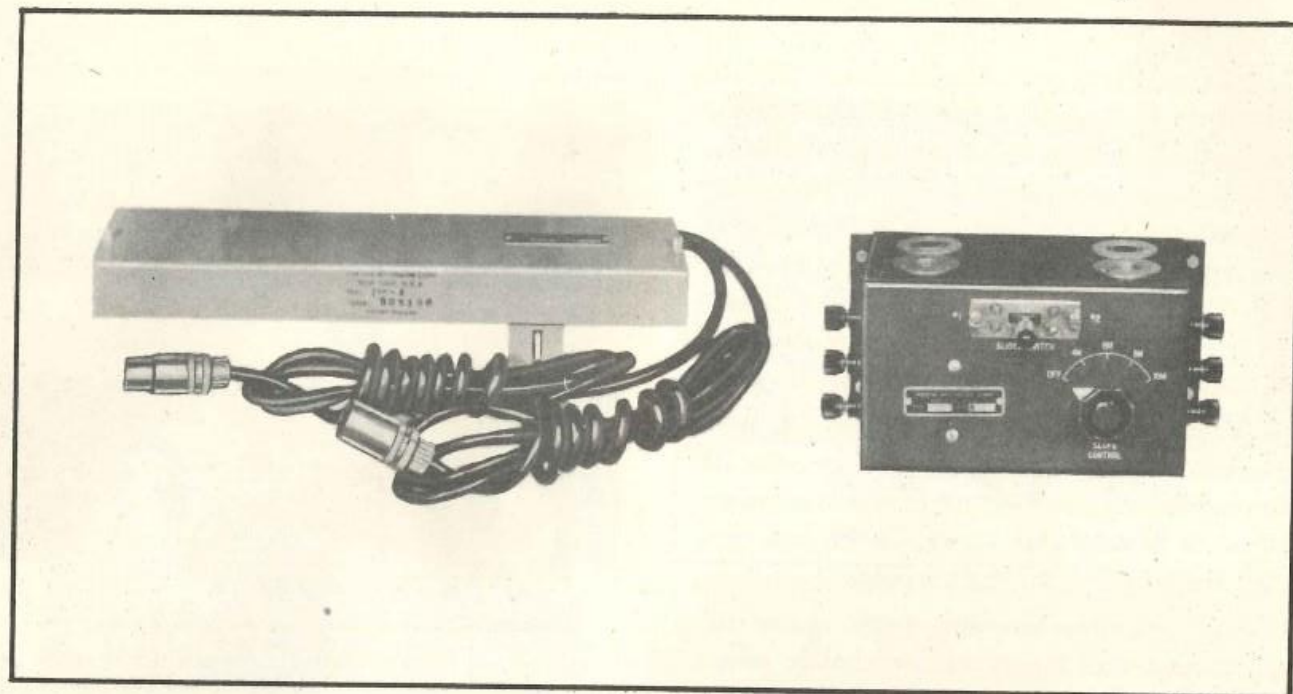

THE PRESTO automatic equalizer provides the only practical means for keeping the response of 33 $\frac{1}{3}$ RPM recordings uniform throughout. With close supervision a skilled operator can produce similar results by manual operation but this is seldom possible in a busy recording studio or broadcasting station. For this reason the Presto automatic equalizer is used in practically all studios that produce high quality electrical transcriptions.

In recording at 33 $\frac{1}{3}$ RPM there is a progressive attenua-

tion of the higher frequencies as the radius of the groove becomes smaller, because the linear speed of the record past the needle becomes slower.

These losses can only be compensated for by artificially increasing the amplitude of the higher frequencies while recording. The Presto automatic equalizer holds the input to the cutting head at a constant level and at the same time continuously alters the frequency response of the amplifier to correct for the attenuation which occurs on playback.

TYPE 40-A AND B PREAMPLIFIERS

These preamplifiers are intended for use with Presto recording amplifiers. They are similar to the recording amplifier in appearance and have the same frequency response. The 40-B amplifier is mounted on a relay rack panel. The 40-A amplifier is mounted in a carrying case and contains a switch for changing the input impedance to use a 50, 200 or 500 ohm microphone.

Gain: 50 db.

Tube Complement: One 6-J-7, One 6-S-J-7.

Impedance: Input 50/200/500 ohms. Output 500 ohms.

Operating Dimensions and Weight: Type 40-A case closed 15" x 8" x 10" (38 x 20 x 25 cm.). Weight 18 lbs. (8 kg.). Type 40-B 19" x 5 $\frac{1}{4}$ " x 8" (48 x 13 x 20 cm.). 10 lbs. (5 kg.).

Shipping Weight: 30 lbs. (14 kg.).

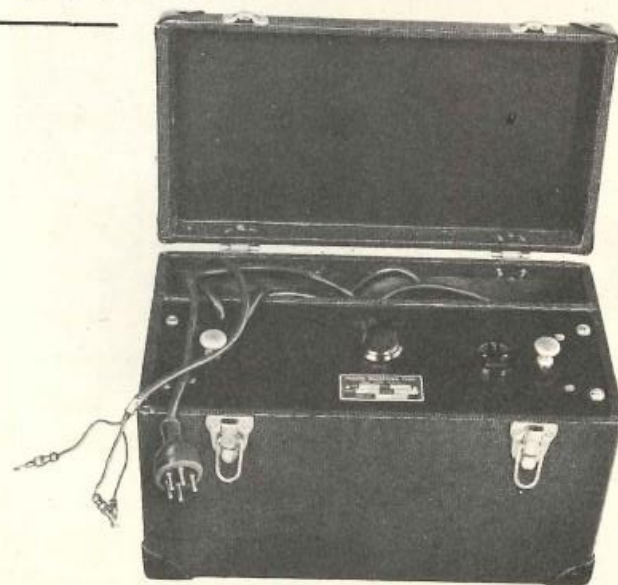

TYPE	DESCRIPTION	PRICE	CODE
40-A	Portable preamplifier		RAMPE
40-B	Rack mounting preamplifier		RABIT

PRESTO TYPE 125-A MICROSCOPE

ALL experienced recording engineers make a test cut before recording. They examine the cut under a microscope to determine the condition of the cutting needle and disc and to judge the depth and quality of the record groove.

The 125-A microscope gives a magnification of 40 times and shows 7 grooves in perfect focus. It shows clearly the defects in a groove caused by an imperfect cutting needle and magnifies the groove and wall enough to enable the user to judge quickly the ratio of groove to wall width. The 125-A microscope is furnished complete with a heavy cast iron extension bracket, mounting post, lamp, reflector and step down transformer. It can be installed on any 16" Presto recording turntable.

Shipping Weight: 10 lbs. (4.5 kg.).

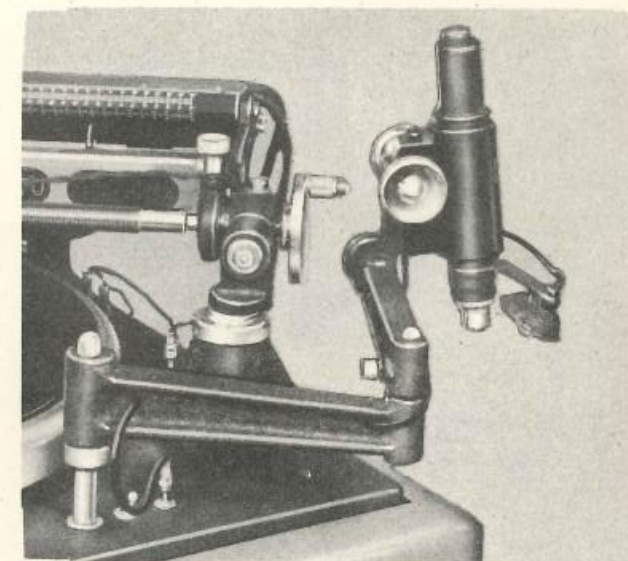

TYPE	DESCRIPTION	PRICE	CODE
125-A	Microscope		MICRO

PRESTO REPLACEMENT PARTS

TYPE	DESCRIPTION	PRICE	CODE	TYPE	DESCRIPTION	PRICE	CODE
5-A	Cutting head for model K recorder		BABOT	131-D	Spring, counterbalance, for model K		BAQUE
102-E	Idler wheel, 78 RPM, for 6-N table		BACEL	145-A	Motor for 8-N table		BARRE
103-E	Idler wheel, 33 $\frac{1}{3}$ RPM, for 6-N table		BADIM	146-A	Motor for 6-N table		BASTA
104-A	Idler wheel, 78 RPM, for 8-N table		BAFAR	147-A	Motor for 75-A and 62-A tables		BATHE
105-A	Idler wheel, 33 $\frac{1}{3}$ RPM, for 8-N table		BAGET	148-A	Motor for model K recorder		BAUVE
116-N	Overhead feed mechanism (p. 1015-A)		BAILE	150-C	Pickup for 8-N, 6-N tables		BAYLA
127-A	Rubber tire for 75-A table		BAJRE	150-D	Pickup for model K recorder		BAWLO
127-B	Rubber tire for model K recorder		BAKER	150-E	Pickup for 75-A		BAWHI
128-N	Overhead feed mechanism (p. 1013-A)		BALLY	220-A	Grommet motor mounting, Set		BAXXE
131-A	Spring, counterbalance, for 8-N table		BAMPF	230-A	Pulley, motor drive, for 8-N table		BAYER
131-B	Spring, counterbalance, for 6-N table		BANTE	230-B	Pulley, motor drive, for 6-N table		BAZLU
131-C	Spring, counterbalance, for 75-A table		BAPPY	230-C	Pulley, motor drive, for 75-A table		BEATH
				230-D	Pulley, motor drive, for 62-A table		BEBBO
				231-A	Pulley, motor drive, for model K		BECON

FEED SCREWS FOR 8N AND 6N RECORDERS

Additional or replacement feed screws may be obtained for the 8N and 6N recorders. Specify type number 32A and give the model of the recorder with which the feed screw is to be used, direction of feed and number of lines-per-inch desired.

Presto Type 300-A Re-Recording Equipment



300-A EQUIPMENT ON MODEL "K" RECORDER

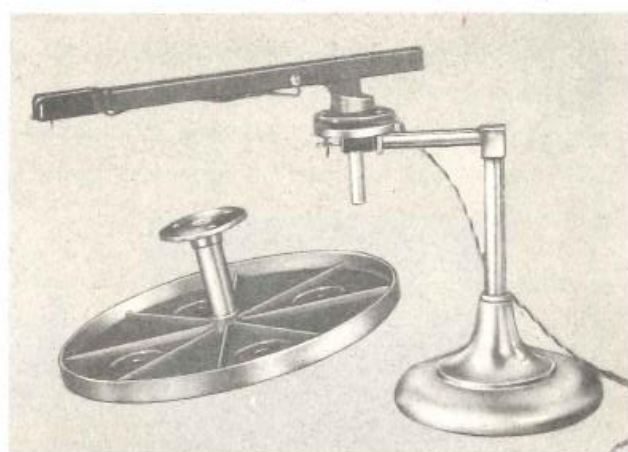

The type 300-A re-recording equipment consists of an auxiliary turntable, which mounts on top of the recording turntable and an external pickup mounted on a pedestal. For re-recording or dubbing the 300-A equipment has several important advantages over a separately driven turntable. 1) The rotation of the recording and playing turntables is locked together so that the playing time and pitch of the duplicate record are identical with the original. 2) No wows or wavers can be introduced during the re-recording since any variation in speed will occur simultaneously on both tables. 3) It is less expensive than a second complete turntable.

The 300-A equipment may also be used with the Presto model K-8 recorder to play 16", 33 $\frac{1}{3}$ RPM electrical transcriptions.

Standard Equipment: The complete 300-A equipment consists of a 140-A turntable, 141-A magnetic pickup and 142-A pickup pedestal.

Frequency Response: Pickup 70 to 7,500 cycles.

Impedance: Pickup 2,000 ohms.

Finish: Gray enamel.

Shipping Weight: 25 lbs. (11 kg.).

TYPE	DESCRIPTION	PRICE	CODE
300-A	Complete re-recording equipment		RUBAB
140-A	Turntable, only		RUCEL
141-A	Pickup, only		RUFFE
142-A	Pickup Pedestal, only		RUTAR

PRESTO Recording Discs

PRESTO Cutting Stylus

PRESTO Playback Stylus

PRESTO

THE WORLD'S LARGEST MANUFACTURERS
OF RECORDING EQUIPMENT AND DISCS



Description and Specifications

DISCS

Green Label

More than a decade ago PRESTO developed and produced the first lacquer coated aluminum-base recording disc known to the industry. Several formulas have been used since the original and today PRESTO produces a recording disc unsurpassed by any in the industry. It is known as the GREEN LABEL disc. Broadcast stations, recording studios and transcription manufacturers find the GREEN LABEL ideal for their most exacting needs. The user is assured of low surface noise, adequate chip throw, and maximum number of playbacks with least possible wear. Extremely rigid inspection assures maximum uniformity of quality.

The GREEN LABEL disc is manufactured in 11 7/8" (12"), 13 1/4" and 16" diameters. Thickness is .052", .052" and .056" respectively.

Oversize Discs for Masters

This type is similar to the Green Label in every respect except for diameter and thickness. No label is stamped on oversize discs which would interfere with processing. Oversize discs are manufactured in 13 1/2" and 17 1/4" diameters. Thickness is .066" for both sizes.

Masters for 10" pressings are generally recorded on either an 11 7/8" or a 13 1/4" regular Green Label disc. Masters for 12" pressings are often recorded on a 13 1/4" regular Green Label in place of the extra heavy 13 1/2" Oversize disc.

Monogram Discs

This disc is composed of the finest grade of lacquer applied to a heavy composition non-metallic base. Its usefulness is comparable to the ORANGE LABEL, but the cost is even more economical. The MONOGRAM disc is manu-

Brown Label (Formerly Type "B")

This disc is selected from regular Green Label and Oversize stock during inspection. One side is perfect and the secondary side bears a slight defect which may or may not be noticeable. The BROWN LABEL is offered because many discs, particularly at broadcast stations — are cut on one side only. There are many other occasions such as air checks, rehearsals, etc., when both sides of this disc are adequate for the type of work being done and a saving of cost is realized compared to the GREEN LABEL and regular OVERSIZE DISCS.

BROWN LABEL discs are available in all GREEN LABEL and OVERSIZE disc diameters.

Orange Label

The aluminum base of the ORANGE LABEL disc is of lighter gage (thickness .040") than the GREEN LABEL and is made in 6 1/2", 8", 10" and 11 7/8" (12") diameters. It is ideal for schools, musicians, artists and all those having need for a recording disc not larger than 11 7/8" at an economical price. The lacquer with which the ORANGE LABEL is coated is equal in quality to that used on the GREEN LABEL.

factured in 6 1/2", 8", 10", 12" and 16" diameters. The 16" size is useful to professional and commercial recordists when economy is essential and maximum quality of sound reproduction is not required.

CUTTING AND PLAYING STYLII

Sapphire Cutting StylII

SAPPHIRE stylII give the best possible results and should always be used unless specific conditions require the use of another type. The shanks are available in either brass or duralumin — the latter has the better high frequency response. Tip angles of 87° and 70° are carried in stock. The 87° stylus is normally supplied. The shanks are produced in long and short lengths. The Presto 1-B, 1-C and 1-D cutters require the long shank. All other cutters take the regular short shank.

SAPPHIRE stylII may be returned for resharping.

Stellite Cutting StylII

The stylus consists of a duralumin shank with a steel alloy tip known as STELLITE. This type will cut a groove comparable to that cut with a SAPPHIRE but the life of the STELLITE tip is considerably less. The STELLITE, however, has the advantage of being unbreakable. It is supplied with long and short shanks.

STELLITE stylII may be returned for resharping.

Steel Cutting StylII

STEEL cutting stylII do not produce a cut of a quality as good as the SAPPHIRE or STELLITE stylII, and have a relatively shorter life. This type cannot be resharping.

Sapphire Playing Needles

This needle is of the conventional type with straight duralumin shank and sapphire tip. It will give about 500 hours of service on vinylite recordings but considerably less on shellac records.

Transcriptone Playing Needles

This is a semi-permanent alloy needle having a tip properly designed for playing transcriptions and phonograph records. It will give about 45 hours of service on vinylite pressings — less on shellac records.

Red Shank Playing Needles

These are similar to conventional steel phonograph needles but are individually shadowgraphed to insure the quality of the tip. The tip is shaped to produce the least possible wear on vinylite pressings. This needle should be changed after each 15 minute recording.

Prices

(Effective February 20, 1947)

TYPE and NUMBER	SIZE	LIST PRICE PER DISC		PRICE PER NEEDLE
Green Label Discs				
611-A	11 7/8"	Packed 30 to the carton	\$1.80	
613-A	13 1/4"			
616-A	16"			
Oversize Discs (For Masters)				
(Packed 17 1/4", 20 per carton - 13 1/2", 30 per carton)				
623-A	13 1/2"		3.05	
627-A	17 1/4"		4.90	
Brown Label Discs (Green Label having only one side perfect)				
	11 7/8" (12")	Packed 30 to the carton	1.30	
	13 1/4"			
	16"			
	13 1/2" (Masters)			
	17 1/4" (Masters)			(20 to carton)
Orange Label Discs				
306-A	6 1/2"	Packed—Carton of 5 packages of 10 discs each	.35	
308-A	8"			
310-A	10"			
312-A	12"			
Monogram Discs				
706-A	6 1/2"	Packed — 50 discs per carton	.20	
708-A	8"			
710-A	10"			
712-A	12"			
716-A	16"			(Packed 25 per carton)
Sapphire Cutting StylII				
320-A (Brass Shank—Short)	(Box of 6)		\$6.00	
321-A (Brass Shank—Long)	(Box of 6)		6.00	
603-A (Dural Shank—Short)	(Box of 6)		8.00	
604-A (Dural Shank—Long)	(Box of 6)		8.00	
Resharping Sapphire			3.00	
Stellite Cutting StylII				
330-A	(Box of 6)		2.00	
331-A	(Box of 6)		2.00	
807-A Resharping stellite point			.75	
Steel Cutting StylII, Long and Short				
350-A	Package of 3		1.00	
350-B	12 Packages of 3		12.00	
Sapphire Playing Needle				
420-A				1.25
Transcriptone Playing Needle				
430-A				1.00
Red Shank Playing Needles				
440-A	Package of 25		.25	
440-B	40 Packages of 25		10.00	

Prices subject to change without notice.

Packing



GREEN LABEL, BROWN LABEL, REFERENCE and 13 1/2" OVERSIZE discs are packed 30 to a carton consisting of three packages of ten discs each. The 17 1/4" OVERSIZE is packed 20 to a carton consisting of two packages of ten each.

ORANGE LABEL discs are packed 50 to a carton containing five packages of ten discs each. MONOGRAM discs are packed 50 to the carton — without internal packages, with the exception of the 16" MONOGRAM which are packed 25 to the carton.

SAPPHIRE and STELLITE cutting stylii are contained in lucite capsules and enclosed in individual boxes containing a cloth mailing bag addressed to Presto to be used for returning stylii for resharpening. Cartons containing six boxes of individual stylii are also available.

All playing needles and the steel cutting stylii are contained in individual glassine envelopes. RED SHANK playing needles are packed 25 to an envelope and also may be had in boxes of forty envelopes.



Suggestions for Handling Discs

Do not open packages until discs are to be used.

Lift the top disc from the stack, holding the disc by its extreme opposite edges. Do not grasp one edge of a disc and allow the other to slide across the disc immediately beneath it.

Keep the surface of the recorder turntable absolutely clean, otherwise the lower surface of a new disc placed on the turntable will be damaged.

Do not remove the "chip," either during or after recording, with the bare fingers.

Protect new discs from dust after package has been opened.

Do not apply any preparation to the surface of a disc before recording.

A cylinder of compressed nitrogen with a suitable pressure regulator, hose and nozzle is ideal for cleaning the surface of discs prior to recording and for blowing loose dirt from the grooves of a disc from which a re-recording is to be made.

Do not stack large numbers of discs in cartons in such a way that excessive pressure is developed in the bottom carton.

Unused discs may be kept for 12 to 18 months before use, without ill effects.

Very rapid groove wear will result from worn or improper playback stylii, and from heavy reproducers, and reproducers having armatures with high mechanical impedance.